

Operating instructions

Pig Location System

104140 – 18.06.2004



Contents	Page
1 Applications.....	1
2 Modular structure and operating principle.....	2
3.1 Technical design of the sending unit.....	3
3.2 Technical design of the receiving unit.....	4
4 Start-up	5
4.1 Start-up of the sending unit.....	5
4.2 Start-up of the receiving unit	5
5 Battery maintenance	6
5.1 Battery of the sending unit	6
5.2 Battery of the receiving unit.....	6
6 Practical work.....	7
6.1 Functional check	7
6.2 Tracing a moving pig.....	7
6.3 Reporting the pig passage	7
6.4 Location of a lost pig	8
6.5 Depth measurement of a lost pig	8
7 Theory and physical principle.....	9
Appendix	11
Overview: Types of transmission pigs.....	11
Overview: Assignment of battery chargers and transmission pigs	13

1 Applications

Pipeline pigs are used, for example, for separating individual oil products in pipelines (separation of different oil types) or for cleaning pipework (cleaning pigs).

Due to various reasons it may occur that a pig is lost somewhere inside the pipe (e. g. collision with an unknown object).

Pig location systems permit to find pipeline pigs which were lost in the pipe.

For special situations, the pig location system is also available as a pig signalling unit. In this case, the unit registers the passage of the pig at a given point of the pipe and transmits an appropriate signal to a monitoring station.

A condition for detecting the pig is that the route of the pipe is precisely known within a range of max. 1 m.

(There are special devices and location methods available for determining routes. If you require further information please contact us).

2 Modular structure and operating principle

The Pig Location System consists of a sending and a receiving unit. Both units are battery-operated and therefore location-independent.

The **sending unit ("pig transmitter")** transmits constantly send signals when the pig passes through the pipe (or when the pig is lost in the pipe).

The send signals are generated by a coil with iron core which radiates a pulsating magnetic alternating field. The alternating field penetrates pipe walls and the soil. Combined with a suitable receiving unit, it can be used aboveground to detect the pig.

Is it unknown which pipe-laying depth is the limit for using this location method with exact results. However, pigs were successfully located in a depth of 6 m.

The portable **receiving unit** consists of a detector coil, an amplifier and headphones.

The voltages which the pig transmitter induces in the detector coil (i. e. the receiving antenna) are made audible and visualized with the help of the amplifier. Depending on the actual pulse rate of the transmitter, the deflection is visualized on the indicating device and made audible as sound signals by the headphones.

3 Technical design

3.1 Technical design of the sending unit

Pig transmitters are available in different versions (refer to the appendix for more information). The types F120 and F190 are flanged onto the existing pig, the types SL 6" and SL 8" are designed as autonomously running devices with own cuffs.

The pig transmitter is equipped with a rechargeable battery and rated for an operating pressure of 100 bar. The electrical components of the transmitter are firmly die-cast in the housing to ensure a high resistance against mechanical stress. Strong mechanical stress occurs in particular when the pig accelerates on its passage.

A pulse-type send signal is used

- to extend battery operation and
- to permit a better distinction between the signals and interfering noise.

A sound/pause relation with a duration of one second each has proven to be practical (i. e., a 1 second send signal is followed by a 1 second pause, and so on).

The housing of the standard pig transmitter consists of two parts:

- Battery case (steel)
- Housing of the actual transmitter (plastic)

A plastic housing is necessary for the transmitter to ensure that the send signal – which is already absorbed by the pipe walls – is not further attenuated.

Note on installing the unit in a pig:

The transmitter part must always stand out freely from the pig to ensure that the send signal is not unnecessarily attenuated. Only the battery part may be placed in the metallic pig body (see fig. 1).

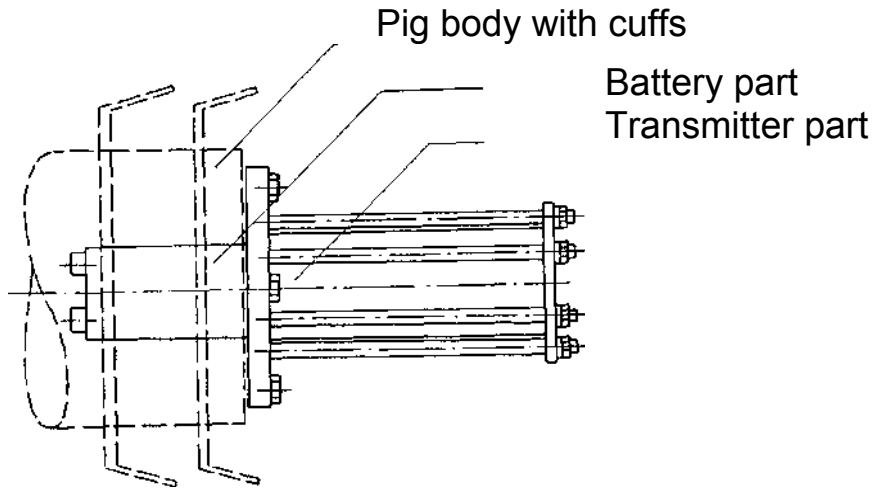

Fig. 1: Installation of the pig transmitter (schematic representation). The transmitter part remains free.

All transmitter types operate according to the same principle and can be located with the receiving unit (receiver ME5, detector coil FS 20 and headphones).

A specific battery charger is required for the sending unit. This charger is rated for the respective battery capacity.

3.2 Technical design of the receiving unit

The pig-location receiver is equipped with eight batteries (1.5 V LR14 batteries). If they are connected in series, they yield an operating voltage of 12 V.

Loosen the screw below the receiver housing to open the battery compartment. A sticker in the battery compartment shows how to insert the batteries (pay attention to the correct polarity!)

The charging state of the batteries is indicated by a small element on the front panel. Replace the batteries when the pointer changes from green to red.

The power consumption of the receiver depends on the volume of the headphones. The minimum period of operation is approx. 100 hours.

Protection against unintentional battery consumption

The receiver is only ready for use after

- connecting the plug-in coupling of the detector coil, and
- after pressing the ON button.

The charging state of the batteries is only indicated if the detector coil is connected.

4 Start-up

4.1 Start-up of the sending unit

To switch on the pig transmitter, you need to bridge the two contacts at the end of the battery compartment with the appropriate strap.

4.2 Start-up of the receiving unit

Connect the detector coil and headphones to the appropriate socket contacts of the amplifier (see fig. 2).

Switch on the amplifier by pressing the control button. This button is also used for setting the amplification.

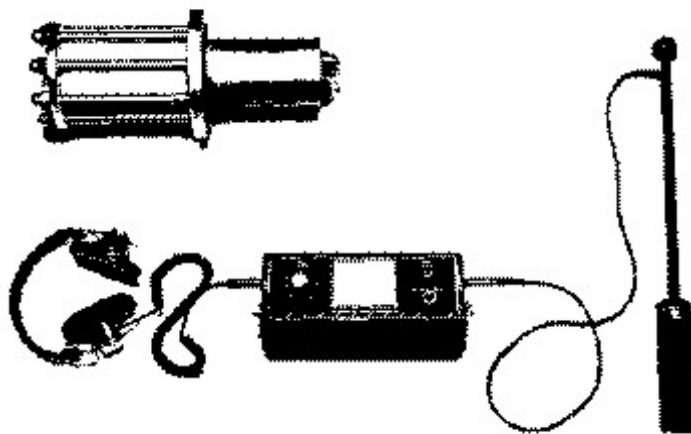

Fig. 2: Pig Location System (sending and receiving unit)

5 Battery maintenance

5.1 Battery of the sending unit

Depending on the used transmitter type, a special battery charger has to be used (refer to the appendix "Overview: Assignment of battery chargers and transmission pigs").

Recharging takes approx. 14 hours if the batteries are completely discharged.

Note that the batteries also gradually discharge during storage. If the transmitter has not been used for 14 days, it is required to recharge the batteries for approx. 5 hours to bring them to full performance.

Caution!

The transmitter has no overcharge protection. For this reason, do not exceed the indicated recharge cycles.

Pay absolute attention to the correct polarity when recharging the batteries:

- **connect the black terminal (minus) of the battery charger to ground (negative pole)**
- **connect the red terminal of the battery charger to the insulated brass screw (positive terminal)**

5.2 Battery of the receiving unit

Replace the batteries of the receiver if they do no longer supply the required voltage (see chapter 3.2).

6 Practical work

6.1 Functional check

The functional check is used to test how far, and in which quality, the send signal can be received under the present conditions (laying depth, thickness of the pipe walls, environmental disturbances).

Perform the functional check after inserting the switched-on pig transmitter into the pipe and after locking the pipe (i. e. before the pig passage starts).

The result of the functional check determines the modulation of the amplifier.

The amplification should be set as low as possible to suppress the effect of interfering signals. (Disturbances can be caused by adjacent lines or if the detector coil is abruptly moved due to the influence of the magnetic field of the earth.)

6.2 Tracing a moving pig

It is relatively difficult to trace a moving pig.

An essential **prerequisite** for this is to maintain the steady velocity of a pedestrian. In addition, the pipe route must be accessible on its entire length without any obstacles.

In hard-to-pass areas, tracing can be made considerably easier if two operators use two receiving units.

6.3 Reporting the pig passage

A pig passing a given point in the pipe can be detected by simply waiting for it.

The receiving unit of the detector coil must be switched on and be positioned on the ground, directly above the point to be examined. If the pig approaches the location, the intensity of the received send signals is clearly increasing and decreasing.

With pig velocities of more than 10 m/s this method can no longer be used reliably, since it cannot be ruled out that the transmitter passes the operator's location during a signal pause.

6.4 Location of a lost pig

A lost pipeline pig can be detected by following the pipe route. Guide the **detector coil vertically** along the pipe, as smoothly and calm as possible. The pulse signal becomes audible in a distance of approx. 6 m (depending on the relevant depth!). The intensity of the signal is increasing when the lost pipeline pig is getting closer. After passing a peak, it drops to a minimum (zero) when it is exactly above the pig. If the operator continues walking, another maximum is indicated again before the signal finally disappears (see fig. 3).

6.5 Depth measurement of a lost pig

If the depth of a lost pig is to be determined, the **coil** needs to be held **horizontally** (coil axis in parallel to the ground). Directly above the pig transmitter a maximum can be detected, however, in same distances in front and behind the transmitter a minimum value.

Rough formula for calculating the transmitter depth (see fig. 3):

$$0.8 \times \text{distance of the two minimum values B1 – B2}$$

7 Theory and physical principle

The procedure for determining the precise location and depth of a lost pig transmitter is based on the physical principle of the induction law.

According to this law, the dimensions of the visual and audible signals (which are determined with the help of the receiving unit) depend on

- a) the strength of the magnetic (transmitter) alternating field and
- b) the angle with which the magnetic field lines meet the longitudinal axis of the detector coil.

If the field lines and the coil axis run in parallel, the induced voltage has its maximum value. If the field lines and the coil axis run perpendicular to each other, the induced voltage is zero (minimum).

As indicated in fig. 3, there is only one position (A) at which the field lines and the coil axis lines meet each other perpendicularly, provided that the coil is held vertically. Position A thus identifies the **location** of the transmitter.

If the coil is held horizontally, two positions (B1 and B2) will be available at which the field lines and the coil axis meet each other perpendicularly. The distance B1 – B2 depends on the **depth t** of the pig and can therefore be used for the depth measurement (see section 6.5).

Pig location is almost impossible if the pipeline runs through saltwater. Due to the electrical conductivity of the saltwater, the magnetic alternating field of the transmitter is absorbed (eddy current effect), so that the signal is no longer transmitted over sufficient distances.

Storage and operating temperatures:

Due to the inserted batteries, the pigs may only be used at temperatures up to approx. 50 °C.

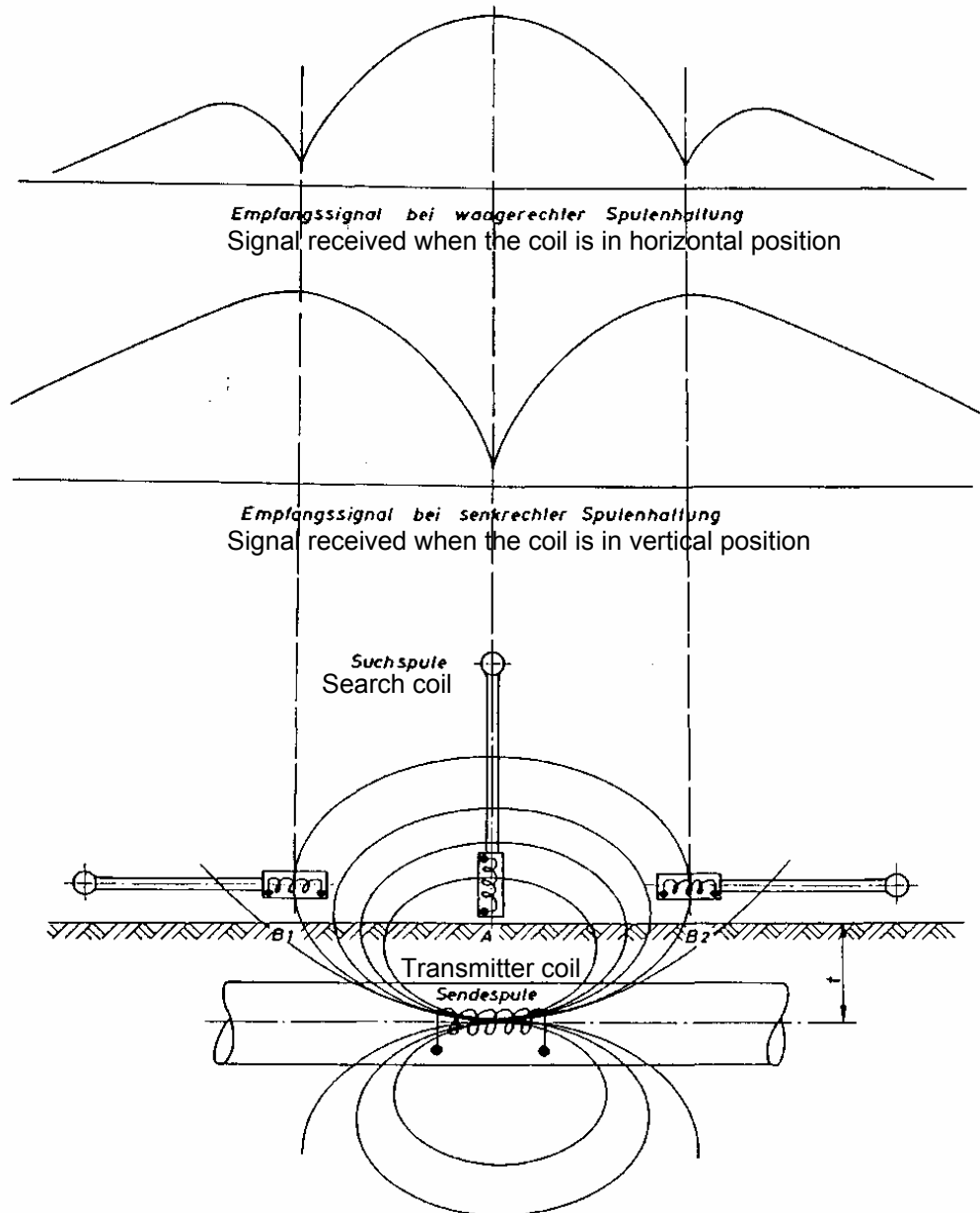

Fig. 3: Determination of location and depth based on the field-line trend:
Location: Pos. A, directly above the transmitter
depth t: $0.8 \times \text{distance } B1 - B2$

Appendix

Overview: Types of transmission pigs

Pig transmitter, type F120/100h

Order no.: MA01-10000

Service life: 100 h / weight: approx. 10 kg

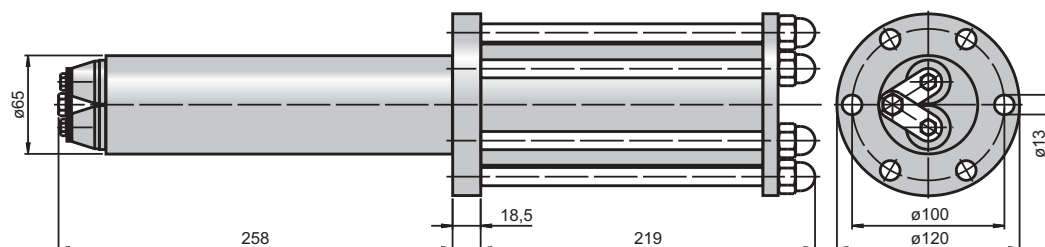

Pig transmitter, type F190

Order no.:	Service life [h]	Length L [mm]	Weight [kg]
MA02-10100	150	168	11
MA02-10200	300	305	15
MA02-10300	450	448	22

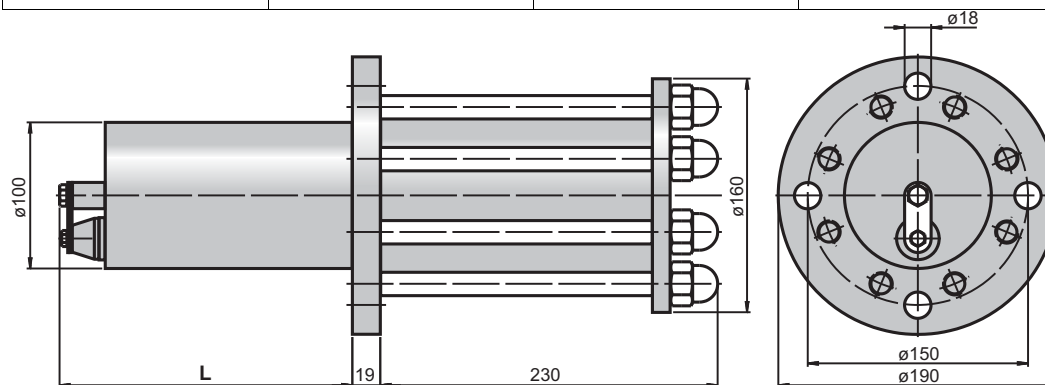

Pig sender, transmitter SL 6"

Order no.: MA04-10100

Service life: 100 h / weight: approx. 10 kg

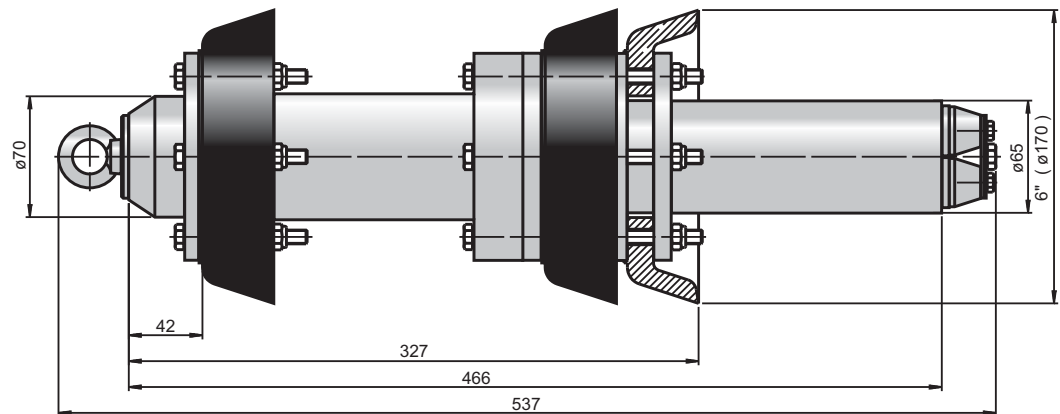

Pig transmitter, type SL 8"

Order no.: MA04-10200

Service life: 100 h / weight: approx. 11 kg

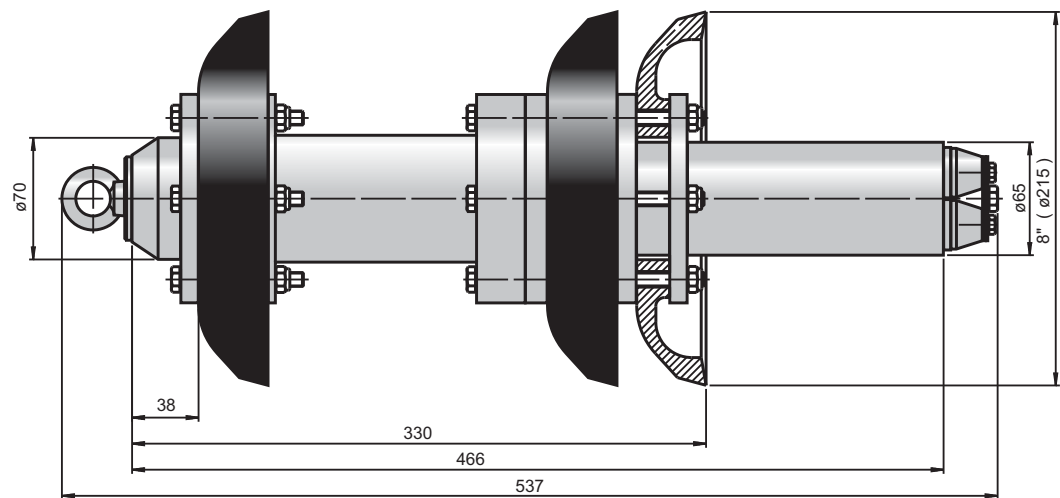

Overview: Assignment of battery chargers and transmission pigs

Battery charger

Transmitter

MA01-Z0300 (100 mA)		MA01-10000 (F120 / 100 h) and MA04-10100 MA04-10200 (SL / 100 h)
MA01-Z0300 (100 mA)		

MA01-Z0300 (100 mA)		MA01-10000 (F120 / 100 h) und / and MA04-10100 MA04-10200 (SL / 100 h)
MA01-Z0300 (100 mA)		

MA02-Z0300 (250mA)		MA02-10100 (F190 / 150 h)
-----------------------	--	------------------------------

MA02-Z0300 (250 mA)		MA02-10200 (F190 / 300 h)
MA02-Z0300 (250mA)		

MA02-Z0300 (250mA)		MA02-10300 (F190 / 450 h)
MA02-Z0300 (250mA)		
MA02-Z0300 (250mA)		

Hermann Sewerin GmbH
Robert-Bosch-Straße 3 · 33334 Gütersloh · Germany
Telefon + 49 5241 934-0 · Telefax + 49 5241 934-444
www.sewerin.com · info@sewerin.com