

# **Ultrasonic Flowmeter**

## **Model UFP-10**




### **Operation Manual**

June 2006

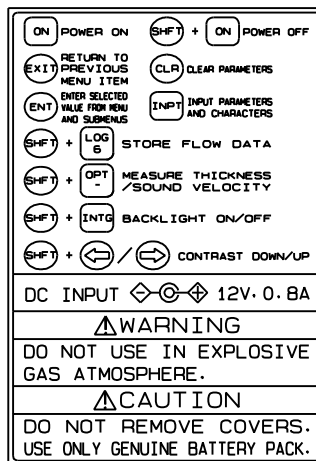
**TOKIMEC INC.**

# Safety Cautions

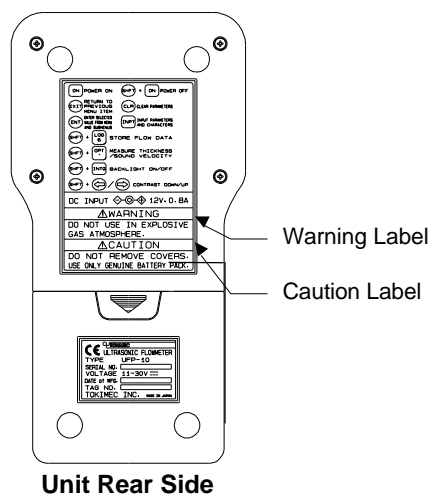
- The various caution messages shown in the Operation Manual and on the unit are defined as follows:

	<b>Danger:</b>	Indicates that incorrect usage can result directly in death or serious injury to the operator.
	<b>Warning:</b>	Indicates that incorrect usage may result in death or serious injury to the operator.
	<b>Caution:</b>	Indicates that incorrect usage may result in injury to the operator or damage to the equipment.

- The following Warning/Caution label is attached to the back panel of the instrument:



- The position of the Warning/Caution label is shown below:



4. Throughout the manual, there are sections in which “ Caution” is written. In addition, “ Prohibited” and “ Note” appear in order to inform the user of items that may affect the performance of the unit. However, these items do not present any danger to the user. Read these sections carefully and ensure a full understanding before attempting to operate this equipment.

## **Introduction:**

---

This Operation Manual includes detailed explanations of Portable Ultrasonic Flowmeter Model UFP-10 safety cautions, structure, set up, operation, troubleshooting, and maintenance. Users should carefully read this manual before operation to ensure an adequate understanding of the equipment.

### **Proper use of the Operation Manual**

The following points must be observed:

- (1) Carefully read the Operation Manual.

The contents of the Operation Manual are very important. Carefully read the entire manual.

- (2) Store the Operation Manual in a safe location.

The Operation Manual is very important for the operation of the equipment. Store the manual in a safe and accessible location. The storage location and manager should be considered carefully.

- (3) Ensure that the Operation Manual is supplied to the operator of the equipment.

The representative or dealer of this equipment must supply this Operation Manual to the user who will actually operate the equipment.

- (4) The Operation Manual must be replaced if it is lost.

If the Operation Manual is lost, contact the representative listed on the back cover. A new manual may be purchased.

- (5) Ensure that the warning label is attached.

Contact the manufacture if the warning label is illegible or has come off. A new label may be purchased.

## **Restrictions and cautions necessary to maintain the equipment.**

The following items must be observed in order to maintain the equipment. Refer to the pages corresponding to each topic for details. The corresponding pages are shown in ( ) brackets.

- (1) Do not drop or bump the unit.
- (2) Use the unit only in appropriate temperature and humidity environments.  
(Refer: p. 2-9, temperature and humidity range: p. 2-9, sensor specifications)
- (3) Always use an appropriate power supply. (Refer: p. 2-9, power specifications)
- (4) Do not connect the 4-20mA analog output to devices with uninsulated inputs. Do not short circuit the power supply. (Refer: p. 3-4, 4-20mA analog output cable connection)
- (5) Do not use damaged or worn-out cables.
- (6) Use only the supplied accessory battery. Use of any other battery may result in explosion or fire. Use only the supplied charger unit when recharging the battery.  
(Refer: p. 3-9, battery charging)
- (7) Do not perform flowmeter sound velocity measurements on liquid chemicals that react to the acrylic ultrasonic radiation surface of the probe.
- (8) Do not replace the internal back-up battery yourself.
- (9) Do not attach the connector to devices other than those specified.
- (10) Do not use this unit or optional devices in restricted areas.

# Cautions for Battery

---

## Outline

Various safety features have been included in the design of this battery, however, misusing or mishandling batteries can lead to fluid leakage, heat generation, fire, or explosion. To prevent these situations from occurring and to ensure safe use of this battery, please strictly observe the following precautions.

## Restrictions on Usage

Restrictions on Usage Environment

- \* The temperature range for Charging and Storage of this battery is as follows.  
Charging: 0 to 40° C  
Storage: -20 to 30° C
- \* Charging this battery outside of this range may cause fluid leakage and generation of heat, as well as impair battery performance and shorten battery service life.
- \* Do not use or store this battery at high temperature, such as in strong direct sunlight, in cars during hot weather, or directly in front of heaters. This may cause battery fluid leakage, impaired performance, and shortening of battery service life.
- \* Do not charge this battery when it is cold(below 0 °C), or outdoors in cold temperatures(below 0 °C). This may cause battery fluid leakage, impaired performance, and shortening of battery service life.
- \* Do not splash fresh or saltwater on this battery, or allow the terminals to be rusted. This may cause heat generation and formation of rust on the battery and its terminals.

## Restrictions on Conditions of use

- \* Do not connect batteries together. This may cause electrical shocks, fluid leakage, and heat generation.

## Preparations Before Use

Please Read this Operation Manual

- \* Before using this battery, please be sure to read this operation manual and precautions. After reading the manual, keep it on hand and refer to it as necessary. If you do not sufficiently understand the manual or precautions, please contact a to our company.
- \* For the procedure for charging this battery, please read the operation manual.
- \* For the procedures for installing batteries from a device, please read the operation manual.

## Do Not Connect Batteries to a Power Source

- \* This battery has (+)(positive) and (-)(negative) terminals. If this battery did not work when connected to device, do not attempt to force the connection. Verify the positions of (+) and (-) terminals. Charging the battery with the terminals reversed may drain rather than change the battery, leakage of or cause abnormal chemical reaction inside the battery, abnormal current flow during discharge, battery fluid, heat generation, bursting or fire. Do not connect this battery directly to a power outlet or insert it into a cigarette lighter socket in a car. High voltage may cause excessive current flow, leakage of battery fluid, heat generation, bursting or fire.

## **Inspection of Batteries Before Use**

- \* If a newly purchased battery has rust, generates heat, or is abnormal in any other way, do not use it. Take it back to the store where you purchased it.
- \* If a battery is to be used for the first time or it has not been used for a long time, be sure to charge it.

## **Non-specified Use**

Do Not Use for Other Than Specified Uses

- \* Do not use this battery in any other device. Depending on the device being used, doing so may cause abnormal current flow, leakage of battery fluid, heat generation, bursting or fire.

## **Methods of Use**

Do Not Misuse Batteries

When using this battery, be sure to observe the following precautions:

- \* Never dispose of this battery in a fire or heat them. Doing so may melt the insulation, damage the gas release vents or protective devices, cause combustion through chemical reaction with generated hydrogen, ejection of battery fluid (electrolyte) from the batteries, bursting or fire.
- \* Do not connect the (+)(positive) and (-)(negative) terminals of this battery with a wire or electrically conductive materials. Do not carry or store this battery together with metal necklaces, hairpins, or other electrically conductive materials. Doing so may short circuit the battery, which could result in excessive current flow and possibly cause leakage of battery fluid, heat generation, bursting or fire.
- \* Do not charge or use this battery with the (+)(positive) and (-)(negative) terminals reversed.
- \* Charging the battery with the terminals reversed may drain rather than charge the batteries, or cause abnormal chemical reaction inside, abnormal current flow during discharge, leakage of battery fluid, heat generation, bursting or fire.
- \* Do not connect this battery directly to a power outlet or insert it into a car cigarette lighter Socket. High voltage may cause excessive current flow, leakage of battery fluid, Heat generation, bursting or fire.
- \* Do not strike or drop this battery. A sharp impact can cause leakage of battery fluid, heat generation, bursting or fire.
- \* Do not transport this battery by holding onto the connectors or lead wires, as this may damage the batteries.

## **Do Not Alter or Remove Protective Mechanisms or Other Parts**

- \* Never disassemble this battery. Doing so may cause an internal or external short circuit or result in the exposed material chemically reacting with the air. It may also cause heat generation, bursting or fire. There is also the danger of alkaline fluid being split.
- \* Never alter or reconstruct this battery. Protective Mechanism (devices) to prevent danger are built into the batteries (single cell or packed cells). If these are damaged, this could result in excessive current flow, control loss during charging or discharging, leakage of battery fluid, heat generation, bursting or fire.

## **Do Not Use in Ways Which Reduce Battery Safety**

- \* The gas release vent which releases internal gas is located at the (+)(positive) terminal section of this battery. Never deform this section or cover or obstruct the release of gas. If the gas release vent cannot function properly, this could result in leakage of battery fluid, heat generation, bursting or fire.
- \* This battery pack is structured to release internal gas. Do not obstruct the gas release structure, as this may cause bursting.

### **When Batteries Are Not In Use**

- \* Be sure to turn off the equipment or the device after using this battery. Failure to do so may cause leakage of battery fluid. During non-use, do not leave this battery connected to the equipment or the device for a long period of time.
- \* To prevent leakage of battery fluid and corrosion(rust) during the period when this is not being used, remove the battery from the equipment or the device and store it in a place with low humidity and at a temperature of  $-20$  to  $+30^{\circ}$  C. Batteries that have not been used for a long time may not be fully charged.

# Contents

---

## Section 1 OverView

1-1 Summary.....	1-1
1-2 Related Operation Manuals.....	1-1

## Section 2 Specifications and Configuration

2-1 Summary.....	2-1
2-2 Configuration .....	2-1
2-3 Product Specifications.....	2-5
2-4 Sensor Specifications.....	2-9

## Section 3 Equipment

3-1 Summary.....	3-1
3-2 Carrying Case.....	3-1
3-3 Unit Connector.....	3-2
3-4 Preparation .....	3-2
(Battery Installation)	
3-5 Cable Connection .....	3-3
3-6 Battery Charging.....	3-10
3-7 Sensor Installation .....	3-11

## Section 4 Operation

4-1 Summary.....	4-1
4-2 Simple Measurements.....	4-1
4-3 Operation Panel.....	4-10
4-4 Startup Check.....	4-11
4-5 Startup .....	4-11
4-6 Flowmeter Display (FLOW Mode).....	4-12
INPUT Mode Operation .....	4-15
(Data set needed for pipe data measurements, etc.)	
INTEG Mode Operation .....	4-25
(Flow integration set)	
A-OUT Mode Operation .....	4-28
(Analog output set)	
CAL Mode Operation .....	4-30
(Compensation coefficient set and analog output calibration)	
CHK Mode Operation.....	4-36
(Confirmation of each set value)	
SYSTEM Mode Operation.....	4-38
(No received wave processing / Moving average times / Compensation for angle of fraction / Time / AGC set)	

LOG Mode Operation .....	4-41
(Measurement data logging (record) set)	
DISPLAY Mode Operation .....	4-47
(Measurement data and logging value & Trend Graph display)	
PRINT Mode Operation .....	4-50
(Printer output set)	
TRANS Mode Operation .....	4-57
(Computer output set)	
OPT (option) Mode Operation.....	4-63
(Refer: thickness & sound velocity and pipe display)	
GAIN Set Mode Operation .....	4-71
LCD back-light ON/OFF .....	4-71
LCD light and shade adjustment.....	4-71
<b>Section 5 Trouble shooting .....</b>	<b>5-1</b>
<b>Section 6 Maintenance</b>	
6-1 Cleaning .....	6-1
6-2 Battery replacement.....	6-1
6-3 Backup battery replacement.....	6-1
<b>Section 7 Term Designation .....</b>	<b>7-1</b>

**Appendix A Pipe data saved in the UFP-10 memory** ..... A-1

**Appendix B Sound velocity data used by UFP-10** ..... B-1

**Appendix C Ultrasonic under water sound velocity chart** ..... C-1

**Appendix D Pipe Chart**

    Cast Iron ..... D-1

    Steel ..... D-2

    KUBOTA FW Pipe ..... D-3

    Vinyl Pipe ..... D-3

    Polyethylene Pipe..... D-3

**Appendix E Menu Flowchart**

    INPUT ..... E-1

    GAIN..... E-2

    INTEG..... E-2

    A-OUT ..... E-3

    CAL ..... E-3

    CHK ..... E-3

    SYSTEM..... E-4

    LOG ..... E-5

    DISPLAY ..... E-6

    PRINT ..... E-6

    TRANS ..... E-7

    OPT ..... E-8

**Appendix F Error Code** ..... F-1

**Appendix G Mode (key) Permission** ..... G-1

**Appendix H Parameter dependance**..... H-1

**Appendix I Function Comparison of Version 2.0E and previous version** ..... I-1

# Section 1 Overview

---

## 1-1 Summary

The ultrasonic flowmeter measures volumetric flow rate without inserting a sensor into the pipes. The flowmeter is effective in a wide variety of flow measurement fields, including waterworks, industry, agriculture, chemical plants, power plants, and industrial drain. The compact, light-weight size of this flowmeter makes it ideal for quick, accurate on-site measurements of a wide range a pipe systems. The flowmeter includes a thickness measurement function and can effectively measure the sound velocity of fluids. Measurement data can be printed, logged or transferred to a computer which can assist data collection and analysis.

The flowmeter allows practical flow management.

## 1-2 Related Operation Manuals

The following optional equipment is available for use with the Portable Ultrasonic Flowmeter Model UFP-10. Carefully read the Operation Manuals that are included with each device.

Printer (Seiko Instruments Inc.) :	DPU-414 Operation Manual
Digital Output Reception Software :	PC Interface Software for IBM PC/AT compatible machine Operation Manual

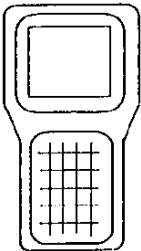
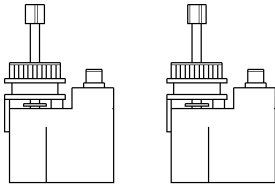
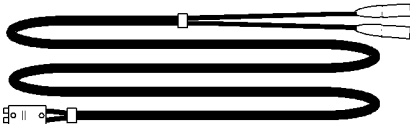
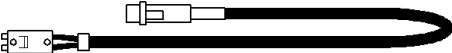
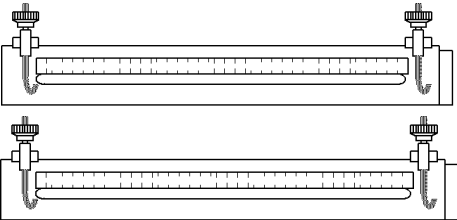
## Section 2 Specifications and Configuration

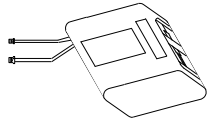
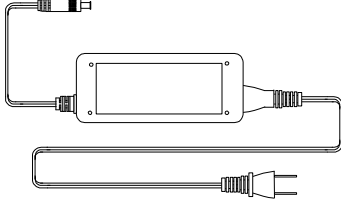
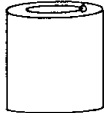

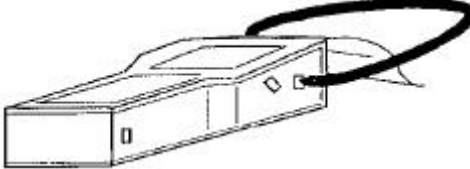
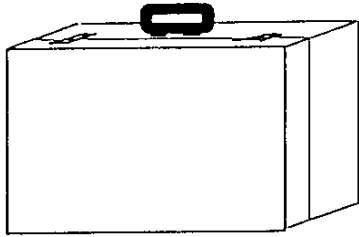
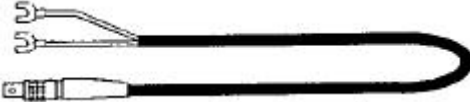
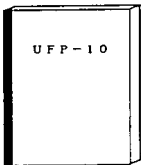
### 2-1 Summary


Section 2 describes the configuration of the UFP-10 and its specifications.

### 2-2 Configuration

#### Main Unit and Standard Accessories

No.	Name	Qty.	Details	Remarks
1	Main Unit	1		
2	Standard Sensor (Appropriate hole diameter: 50A ~ 500A)	2	For flow measurement SE104720G2 	
3	Sensor Cable	1	Length: 10m 	
4	Probe for thickness and sound velocity measurement.	1	Thickness and sound velocity measurement: TH5010G 	
5	Sensor Mounting Fixture	2	For standard sensors 	

No.	Name	Qty.	Details	Remarks
6	Battery (Ni-Cd or NI-H Battery)	1		
7	AC Adaptor	1		
8	Test Piece	1	<p data-bbox="667 663 1038 719">For thickness and sound velocity measurement.</p> 	
9	Couplant	1	<p data-bbox="667 875 863 904">(Silicone Grease)</p> 	
10	Soft Case	1	<p data-bbox="667 1055 772 1084">(W/strap)</p> 	
11	Carrying Case (Holds all equipment)	1		
12	Analog Output Cable	1	<p data-bbox="667 1570 788 1599">Length 3m</p> 	
13	Operation Manual	If any		<p data-bbox="1155 1760 1267 1783">Book size: A4</p> <p data-bbox="1155 1800 1378 1823">Document No.: KF96-001PL</p>

No.	Name	Qty.	Details	Remarks
14	Ferrite Core	4		<p>TDK</p> <p>For AC Adaptor: ZCAT2132-1130</p> <p>For Sensor Cable: ZCAT2132-1130</p> <p>For Analog Output Cable: ZCAT2132-1130</p> <p>For Probe for thickness measurement: ZCAT2032-0930</p>

### Optional Accessories

No.	Name	Qty.	Details	Remarks
1	Large Sensor	2	SE044740G (Appropriate hole diameter: 300A ~ 5000A)	
2	Small HI-Freq. Sensor	2	SE504110 x 10G (Appropriate hole diameter: 13A ~ 100A)	
3	High Temperature Sensor	2	SE104120G2-HT (Appropriate hole diameter: 50A ~ 300A, Temperature Range: 60°C ~ 120°C)	
4	Large Sensor Mounting Fixture	1	For SE044740G	
5	Small Sensor Mounting Fixture	1	For SE504110x10G	
6	High Temperature Sensor Mounting Fixture	2	Same with SE104720G2	
7	Option Sensor Case	1	For each optional sensor	
8	Printer	1	W/ AC Adaptor, Operation Manual, Printer Paper	Printer) SII DPU-414 AC Adaptor) TAMURA PW-4007-E1 INPUT: 230V 50Hz 22W OUTPUT: 6.5V DC2000mA Operation Manual) Document No.: 39010-1828-01
9	Printer Cable	1	CL-9 pin D-SUB cable (2m) with 2 Ferrite Cores	
10	Digital Output reception Software (PC Interface Software )	1	Includes digital output cable with 2 Ferrite Cores	DOS/V
11	Sensor Extension Cable	1	50m with Ferrite Core	

\* Quantity indicates the number of pieces per set.

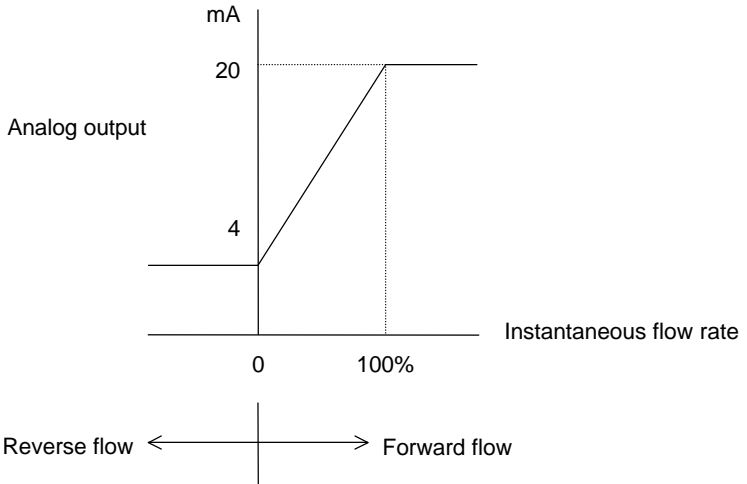
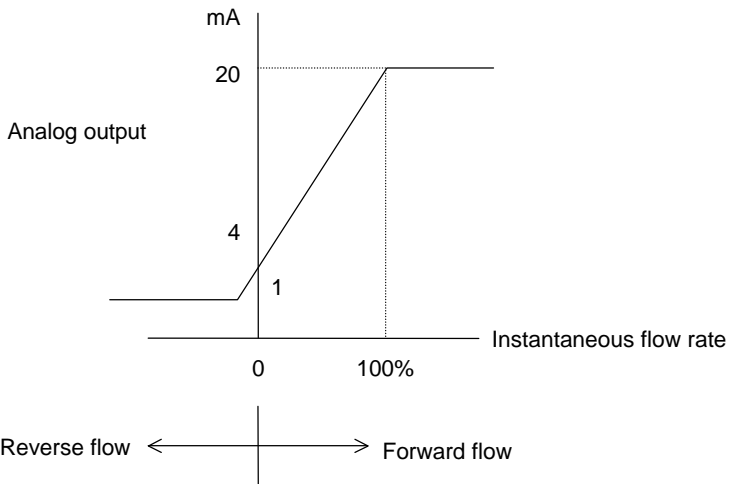
## 2-3 Product Specifications

### 1. General Specification

1. Fluids to be measured:	Type	Fluids that uniformly transmit Ultrasonic waves. (Waterworks, Drainage, Industrial water, River water, Sea water, Pure water, Oil, etc.)	
	Temperature	- 20° C ~ +120° C (Depending on the sensor used)	
	Turbidity	Less than 10,000 mg/L	
	Note	Must contain no air bubbles	
2. Piping	Type	Steel pipe, SUS pipe, Pipes with stable permeability. Ductile cast iron pipe, PVC pipe, Copper pipe, etc.	
	Nominal diameter	13A~ 5000A	
	Lining	No lining or tar epoxy, mortar, etc.	
	Length of straight pipe	Up stream: over 10d, Down stream: over 5d (d: pipe diameter)	
3. Measurement Range	(Flow velocity conversion) -20 m/s ~ +20 m/s		
4. Measurement Period	approx. 45 ms		
5. Measurement Precision *			
		Flow velocity conversion: More than 1 m/s	Flow velocity conversion: Less than 1 m/s
13A** ~ less than 50A		?2.0% RD	?0.02 m/s
50A ~ 300A		?1.5% RD	?0.015 m/s
300A over (more than) ~ 5000A		?1.0% RD	?0.01 m/s
6. Measurement Method	Transit time method		

\* According to factory tests      \*\* Calibration

## 2. Main Unit Specifications (Standard Specifications)

<b>Item 1 Analog Output</b>	
Output Contents	Instantaneous flow rate
Output Type	<p>Allowable Load Resistance: Less than 600 ohm</p> <p>(1) 4 ~ 20 mA DC current output (uninsulated) Output pattern</p>  <p>(2) 1 ~ 4 ~ 20 mA DC current output (un-insulated) Output pattern</p> 
Damping	1, 3, 10, 30, 100 seconds (90% response time)
<b>Item 2 Digital Output (RS-232C Output Specifications)</b>	
Output Contents	Selected: Time, Instantaneous flow rate, Forward flow integration capacity, Reverse flow integration capacity, Error code
Output Method	Data transmission according to RS-232C Standards.

Transmission Period	Selected: 5 seconds, 10 seconds, 30 seconds, 1 minute, 3 minutes, 6 minutes, 12 minutes
Transmission Time	1 minute ~ 99 hours 59 minutes (1 minute setting possible.)
Baud Rate	Selected: 1200/2400/4800/9600 bps
Data bit length	8 bit/ stop bit: 2 bits
Parity check	None
Code	ASCII
Sync Method	No Sync Asynchronous
Note	The following output can also be set: (1) Logging measurement data (2) Measurement condition
<b>Item 3 Printer Output (Digital output terminal used in common.)</b>	
Output Contents	Selected: Time, Instantaneous flow rate, Forward flow integration capacity, Reverse flow integration capacity, Error code, Trend
Transmission Period	Selected: 5 seconds, 10 seconds, 30 seconds, 1 minute, 3 minutes, 6 minutes, 12 minutes
Transmission Time	1 minute ~ 99 hours 59 minutes (1 minute setting possible.)
Printer	Specialized Printer (RS-232C, 8 bit, No parity, 9600 bps, carriage return and line feed, normal printing, ordinary characters)
Note	The following output can also be set: (1) Logging measurement data (2) Measurement condition
<b>Item 4 Measurement Condition Set</b>	
Set Method	Key input according to on-screen (LCD display) prompts.
Set Items	Analog output, digital output, pipe data set, etc.
Note	32 set conditions can be saved in the memory.
<b>Item 5 Operation Display</b>	
Instantaneous Flow	"Flow Rate" or "Flow Unit" appears on the LCD display.
Integration Flow	"Integration Value" or "Integration Unit" is displayed on the LCD.

<b>Item 6 Display</b>		
LCD Display	Display System	128 x 128 dot matrix (16 columns x 16 lines) w/ LED backlight
	Display Contents	Measurement unit, operation displays, measurement data, such as instantaneous flow, etc.
	Measurement Data Display Digits	Instantaneous flow/instantaneous flow velocity: 4 digits, Integration Flow: 6 digits
	Measurement Data Display Refresh	approximately 1 second
	Note	The display may become difficult to read depending on the surrounding temperature.
<b>Item 7 Functions</b>		
Zero Compensation	Zero calibration is possible within +/- 20% of the maximum indicated flow value.	
Span Compensation	Linear span inclination compensation is possible between 0.5 ~ 2.0.	
Low Flow Cut	Low flow cut is possible between 0 ~ 10% of the maximum indicated flow value.	
Abnormal Value Removal	Abnormal measurement values caused by air bubbles or foreign particles in the test fluid can be removed.	
No Received Wave Processing	Select: Current Value, 0, Maximum Flow ( Displayed value and analog output value)	
Automatic Gain Adjustment Functions	AGA (Automatic Gain Adjustment) automatically sets the gain. AGC (Automatic Gain Control) automatically corrects reception signal fluctuation.	
Refraction Compensation	The refraction angle and sound velocity is automatically compensated in accordance with water temperature fluctuation. (water only)	
Self-diagnostics	Internal self check is performed when the power is turned on.	
Memory backup	An Li memory backup battery is installed to maintain integration flow data, measurement setup data, logging data, and measurement data for approximately 5 years.	
Logging Function	55000 measurement data item memory capacity.	
	Logging Content	Time, Instantaneous flow, Forward integration flow, Reverse integration flow, Error code.
	Logging Sampling Cycle	Selected: 5 seconds, 10 seconds, 30 seconds, 1 minute, 3 minutes, 6 minutes
Thickness Measurement Function	Measurement Range	1.5 ~ 100 mm (Steel plate)
	Sound Velocity Range	500 ~ 9999 m/s

Fluid sound velocity measurement function	A sound velocity measurement cell is used to measure fluid sound velocity.	
	Measurement Range	100 ~ 3000 m/s
<b>Item 8 Power Supply</b>		
Voltage	11 ~ 30 V DC	
	Battery	7.2V DC (Ni-Cd or Ni-H, 2400mAh) Standard Operation Time: 7.5 hours Battery charge time : approx. 4 hours (Full charge)
	AC Adaptor	INPUT: Voltage 90 to 264V AC, Frequency 47 to 63 Hz OUTPUT: Voltage 12V DC, Current 1.5A
<b>Item 9 Power Consumption</b>	Approx. 10W (With 12V supplied, including charging)	
<b>Item 10 Ambient Temperature Range</b>	- 10° C ~ + 50° C	
<b>Item 11 Ambient Humidity Range</b>	Less than 90% RH (Without condensation)	
<b>Item 12 Weight</b>	Approx. 1.1 kg (including battery)	
<b>Item 13 Dimension</b>	118 (width) x 229 (length) x 69 (height)	

## 2-4 Sensor Specifications

No.	Name	Model Number	Appropriate Hole Diameter	Appropriate Temperature	
1	Standard Sensor	SE104720G2	50A ~ 500A	-20° C ~ +80° C	Optional
2	Large Sensor	SE044740G	300A ~ 5000A	-20° C ~ +80° C	
3	Small HI-Freq. Sensor	SE504110x10G	13A ~ 100A	-20° C ~ +80° C	
4	High Temperature Sensor	SE104120G2-HT	50A ~ 300A	+60° C ~ +120° C	

## Section 3 Equipment


### 3 - 1 Summary

All UFP-10 standard equipment and the optional printer can be stored in the unit carrying case for easy transportation to various sites. Furthermore, the UFP-10 unit and printer arrangement allows their operation without removal from the case. This allows effective operation in cramped locations. In addition, the UFP-10 unit has a soft case with shoulder and hand straps for easy carrying and hand-held operation.

The UFP-10 includes a special AC adaptor to operate 90V to 264 AC also available) power sources. Operation is also possible with 11V ~ 30V DC power supplies or an internal battery.

Output functions include a 4 ~ 20mA analog output terminal, printer output terminal, scanner control terminal, and RS-232C digital output terminal.

The unit can be used as an ultrasonic thickness meter by connecting the supplied thickness meter probe to the sensor connector.

 <b>Caution:</b>
<ul style="list-style-type: none"><li>• Take care not to entangle hands or feet in the straps.</li><li>• Keep the cover closed and locked when moving the carrying case. Failure to secure the cover may result in the contents falling out and injury.</li><li>• Do not position the carrying case or equipment in unstable locations. Bodily injury or damage to the equipment may result if the case drops.</li></ul>

### 3 - 2 Carrying Case

The following illustration shows the storage arrangement of the carrying case.

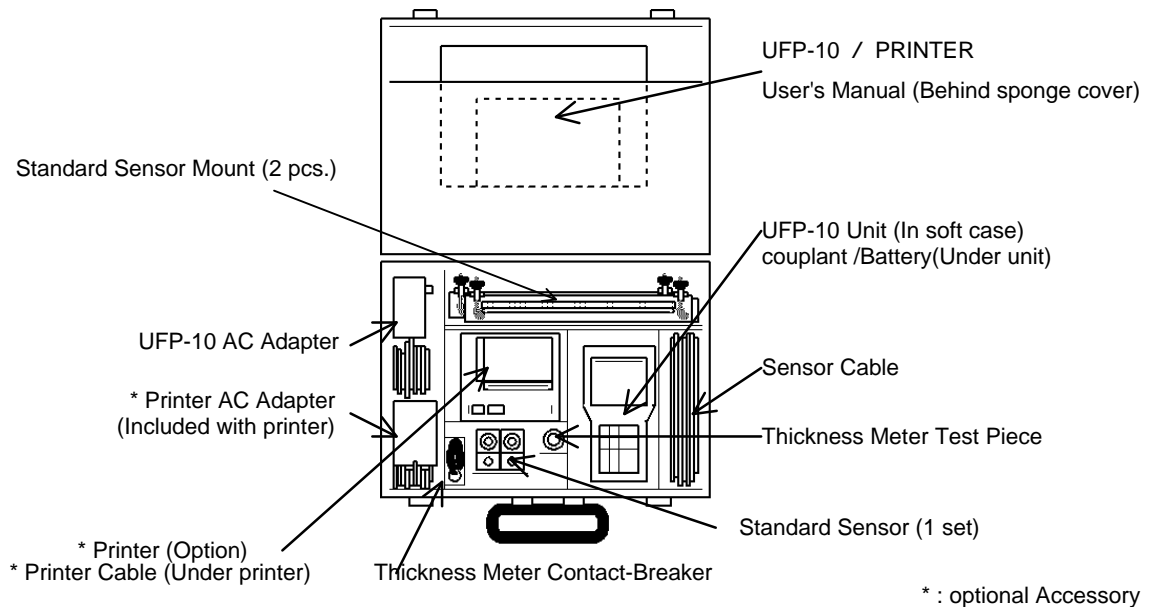


Figure 3 -2 Carrying Case Storage

### 3 - 3 Unit Connector

UFP-10 unit connector location:

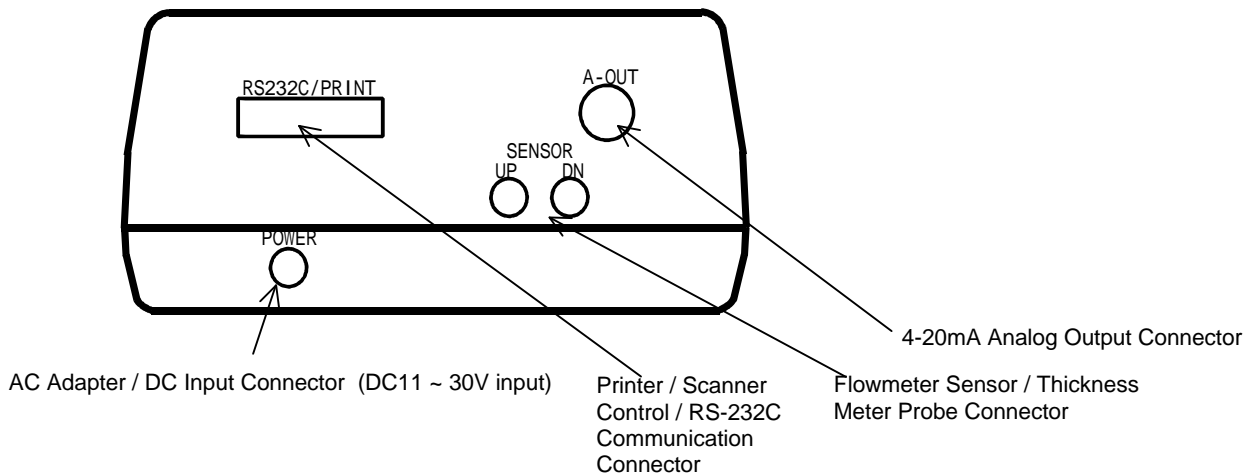
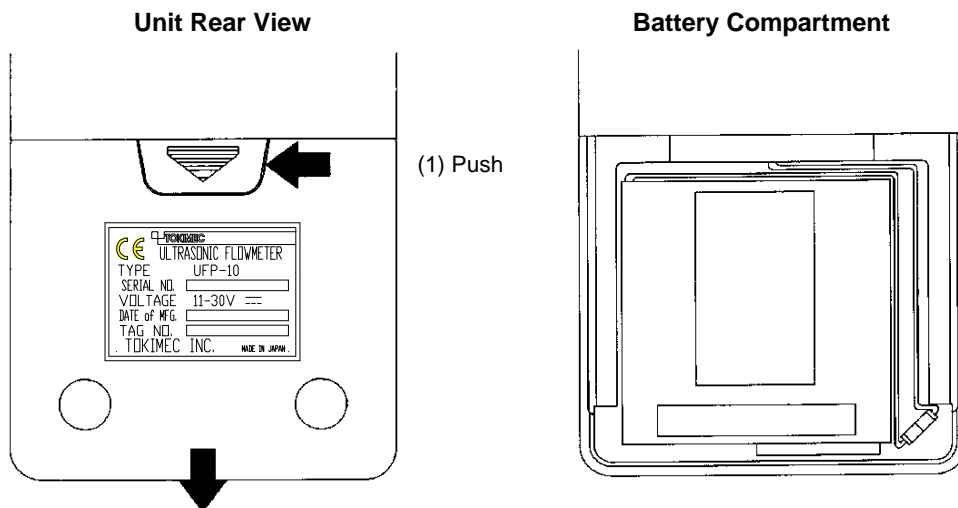


Figure 3 - 3 Connector Location

### 3 - 4 Preparation

The battery is not installed at the factory. The user must install the battery before using the UFP-10. Follow the procedure below when installing the battery:

- (1) Locate the battery cover on the back of the unit. Slide the cover in the direction of the arrow shown in the illustration below and remove.

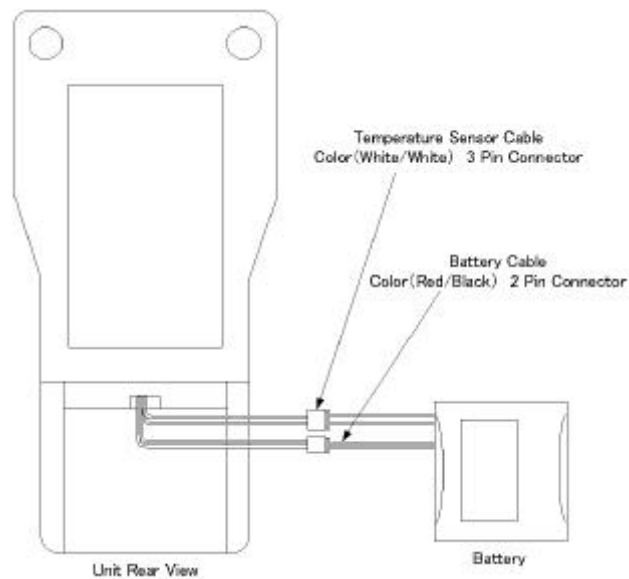


- (2) Slide the battery cover in the direction of the arrow.

Figure 3 - 4 Battery Compartment

- (2) Connect the cables from the battery side with the cables from the unit side. The battery and the unit have 2 kinds of cables, one is the battery cable for charge and discharge,

and the other is the cable of the temperature sensor. Connect both of them as shown in figure 3 - 5. After that, place the battery into the battery compartment and close the cover.



**Figure 3 - 5 Battery Cable Connection**

\* When the battery of former type (there is no cable for the temperature sensor) is used, it is possible to use it by connecting only the battery cable. However, there is a possibility where the battery is deteriorated by the rise of temperature when charging and discharging are repeated under the environment with high temperature.

**Note:**

The battery is not shipped fully charged. Be sure to charge the battery before using the UFP-10. (Refer to Section 3-6, Battery Charging)



**Caution:**

The battery connector is designed to prevent polarity reversal during insertion. Do not cut the connector from the wire or force the connector during insertion. Failure to follow this caution may cause burns or injury. In addition, ensure that broken wires are repaired. Attempting to disassemble or repair the unit is dangerous and may result in electrical shock or injury.

### 3 - 5 Cable Connection

#### (1) AC adaptor and exterior DC power supply cable connection

The UFP-10 may be operated using the internal battery, standard AC adaptor, or an external DC power source such as a car lighter socket. Connect the cable to the connector on the UFP-10 labeled "POWER" when using the AC adaptor or external DC power source. The battery will automatically charge when the AC adaptor or DC power cable is connected to the POWER connector.

#### (2) Flowmeter sensor/ thickness probe cable connection

The connectors on the side of the UFP-10 labeled "UP", "DN" are for sensor cable or thickness probe cable connection. For the flowmeter, connect the upstream sensor cable (10 m) to the "UP" connector and the downstream sensor cable (10 m) to the "DN" connector. For the thickness meter, connect the probe cable (70 cm) with the red-marked terminal to the "DN", and green-marked terminal to the "UP" connector.

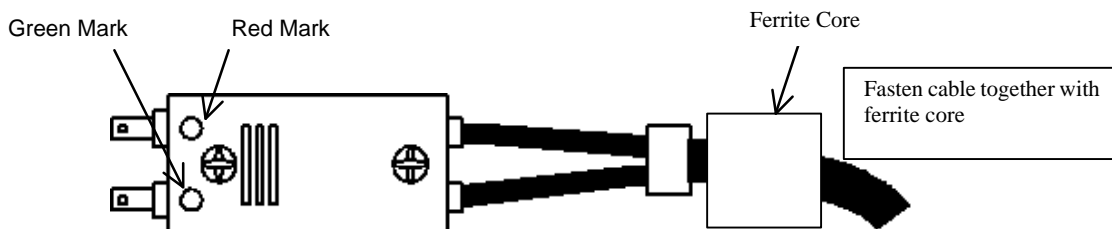
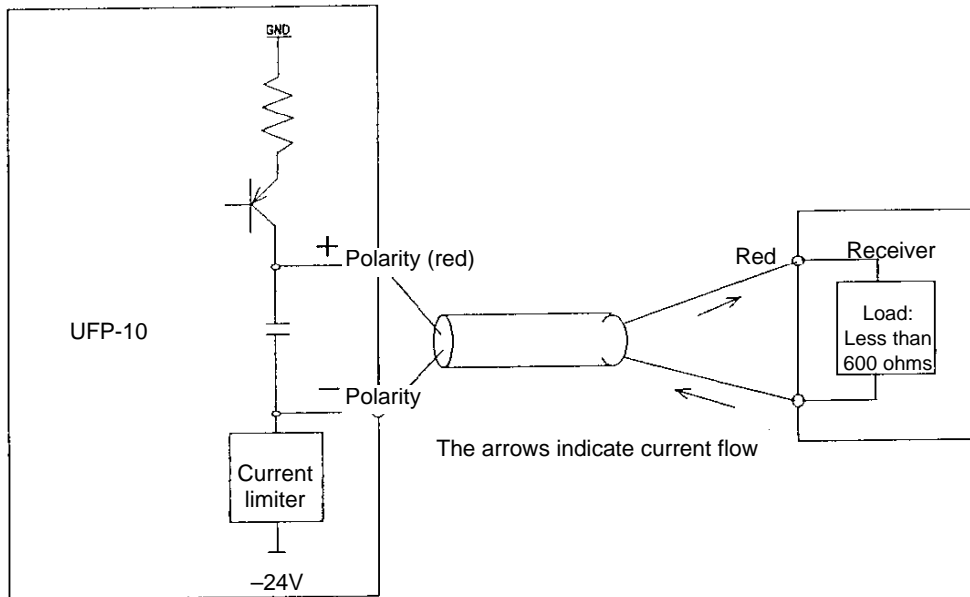


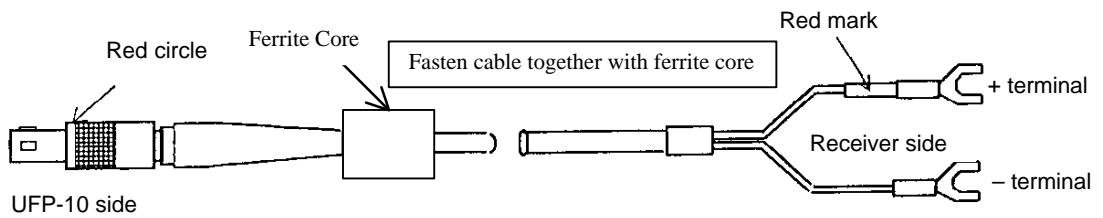
Figure 3 - 6 - 1 Sensor Cable Connector (UFP unit side)

#### (3) 4-20mA analog output cable connection

Connect the supplied analog output cable (2 m) to the connector labeled "A-OUT" for output current. The output circuit is shown below. Do not exceed the allowable load of 600 ohms. Note that the analog output is uninsulated. Before using this cable, designate either 4mA or 20mA from the 4-20 CAL menu in the CAL mode (Refer to Section 4).



**Figure 3 - 6 - 2 4 - 30 Analog Output Configuration**



**Figure 3 - 6 - 3 Analog Output Cable**

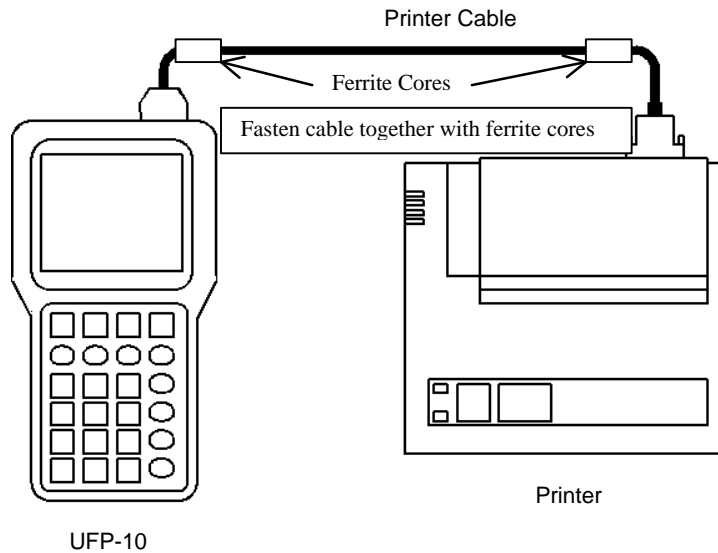
***Note:***

Do not connect the analog output to any device with an unshielded input such as an oscilloscope. In addition, do not connect the analog output to a power source or ground.

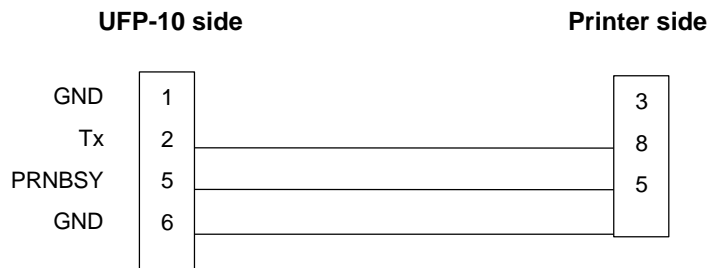
**(4) Printer Connection**

Measurement and setup data can be output to the optional printer through the printer cable connection. Connect the printer cable to the connector labeled "RS-232C/PRINT". The connector case cover is grounded to the internal ground terminal together with the cable shield. The output is uninsulated.

- For the DPU414 printer



**Figure 3 - 6 - 6 - 2 Printer Connection**



**Figure 3 - 6 - 7 - 2 Printer Cable Configuration**

Software DIP switches of the printer are set as follows:

**DIP Switch 1**

Number	1	2	3	4	5	6	7	8
Position	OFF	ON	ON	ON	OFF	OFF	ON	ON

**DIP Switch 2**

Number	1	2	3	4	5	6	7	8
Position	ON	OFF	ON	ON	ON	ON	ON	ON

**DIP Switch 3**

Number	1	2	3	4	5	6	7	8
Position	ON	ON	ON	ON	OFF	ON	ON	ON

To set the switches, refer to 「2.3 Setting the DIP Switches」 of the printer operation manual.

## (5) Digital Output Cable Connection

Measurement and setup data can be output to personal computer through the supplied special cable connection using the "PC Interface Software." Connect the special cable to the connector labeled "RS-232C/PRINT." Refer to the Operation Manual included with the "PC Interface Software" for computer connection and operation instructions. The cable shield is grounded to the unit ground terminal. The output is uninsulated.

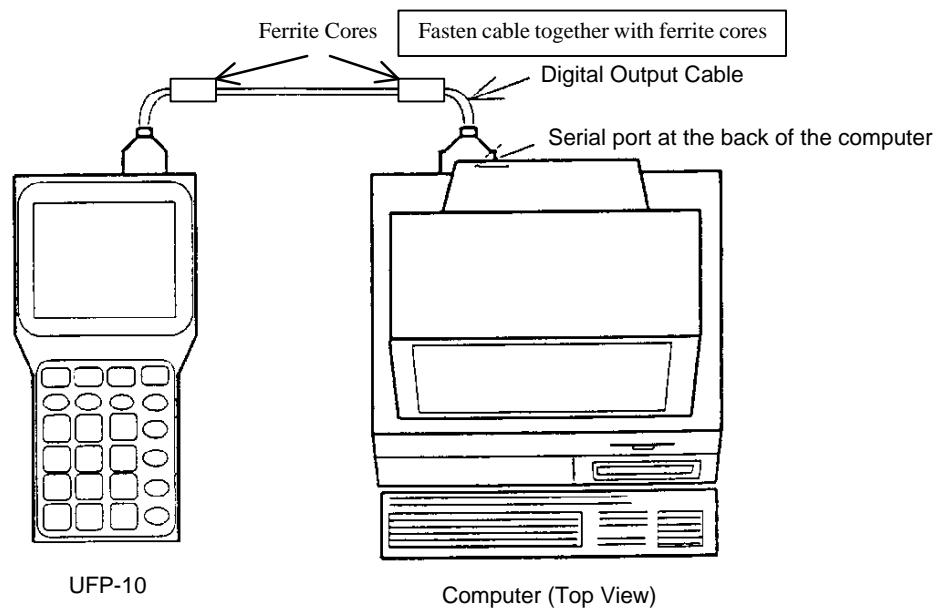


Figure 3 - 6 - 8 Computer Connection

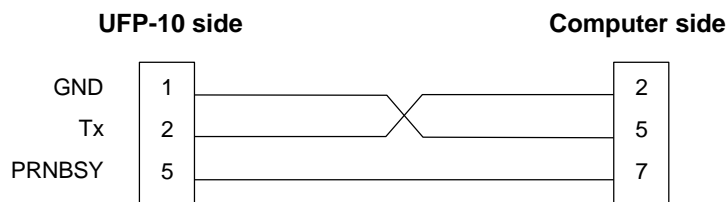

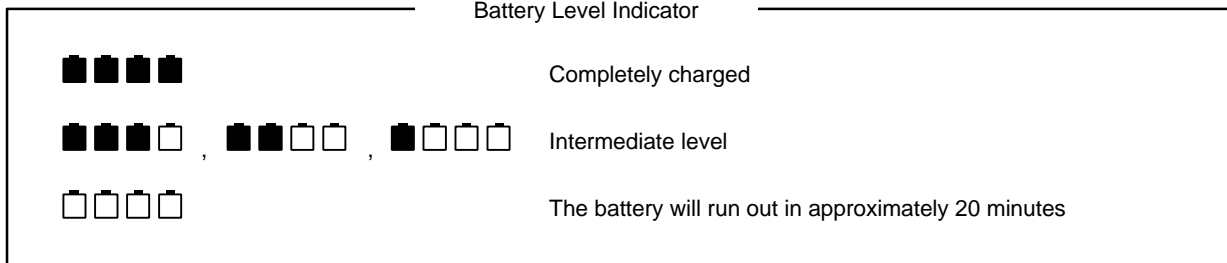






Figure 3 - 6 - 9 Digital Output Cable Configuration

### 3 - 6 Battery Charging

During battery-powered operation, the upper-right side of the LCD display shows a battery level indicator. When this display shows a level of , stop the operation in progress immediately or use an external power source such as an AC adaptor. The battery automatically charges when an external power source is used.



- Full recharge from  requires approximately 4 hours.
- After the battery has been fully recharged, the unit can operate for approximately 7 hours continuously before  will be displayed. However, this operation time is with the LCD backlight off, analog output set at 4mA, and no printer or digital output.
- The power will cut off approximately 20 minutes after  appears.

<b>Note:</b>
<ul style="list-style-type: none"><li>• Ensure that the battery is fully charged before battery-operation of the unit.</li><li>• The power will cut off approximately 20 minutes after  is displayed and all unsaved data will be lost.</li></ul>

The battery automatically recharges when the AC adaptor or DC power source is connected to the UFP-10 "POWER" connector, regardless of whether or not the power is turned on. This allows the battery to be recharged while performing flow measurements.


The battery level indicator appears as  during recharging. This is normal.

### Battery Characteristics

Repeated short-term usage of the battery can lead to the development of voltage memory in the battery. Voltage memory causes the battery to appear fully charged when in reality it is only partially charged. This will result in decreased operation time for the UFP-10 during battery operation. Voltage memory can be corrected by allowing the UFP-10 to operate (battery powered) until the battery is fully drained and the unit cuts off. Then, fully recharge the battery.

<b>Note:</b>
Do not force the battery to discharge using resistors. This will damage the battery.


Following long-term storage, it may become difficult to fully charge the battery. This can result in only partially charging of the battery. The battery should be charged and discharged 2 or 3 times to restore the battery performance.

 <b>Caution:</b>
<ul style="list-style-type: none"> <li>Do not disassemble the battery. The battery may short-circuit, resulting in heat build-up, or contact between the alkaline battery fluid and the skin causing burns.</li> <li>Do not solder the battery cable, even if it breaks. Application of heat to the terminal can destroy the safety valve.</li> <li>Do not use the battery for any other purposes. Failure to follow this caution may result in heat build-up, fire, or explosion and injury.</li> </ul>

### 3 - 7 Sensor Installation

The following sensors are available for the UFP-10 in order to measure a variety of pipe diameters and fluid temperatures.

<i>Pipe Diameter</i>	<i>Fluid Temperature</i>	<i>Sensor Number</i>	<i>Sensor Name</i>	<i>Remarks</i>
50A ? 500A	-20°C ? +80°C	SE104720G2	Standard Sensor	Standard
50A ? 300A 300A ? 5000A 13A ? 100A	+60°C ? +120°C -20°C ? +80°C -20°C ? +80°C	SE104120G2-HT SE044740G SE504110x10G	High Temperature Sensor Large Sensor Small HI-Freq. Sensor	Option

 <b>Caution:</b>
When measuring hot fluids where the pipe becomes hot, the sensor mounting fixture and sensor will also become hot. Take special care when handling the sensor equipment. Touching the pipe or equipment with an unprotected hand may result in burns and injury.

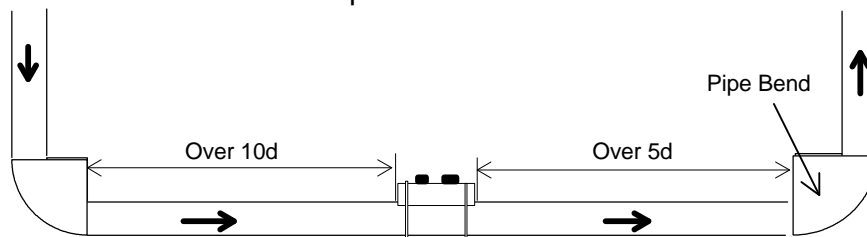
#### Position the sensors as explained below:

(1) **Standard Sensor: SE104720G2 / High Temperature Sensor: SE104120G-HT**

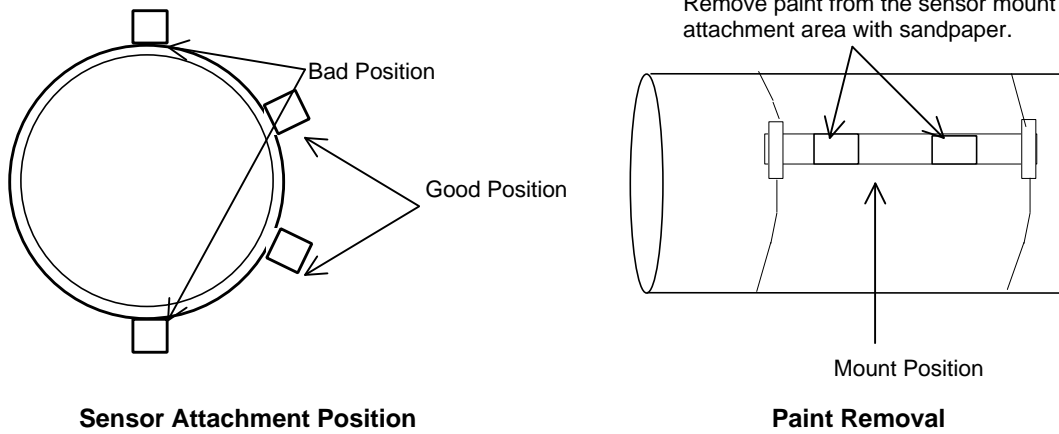
#### Mount Set

Position the standard sensor mounts more than 10d upstream (d is the diameter of the pipe) and more than 5d downstream in a straight line. Attach the sensor mounts parallel to the flow. Avoid the upper and lower sections of the pipe.

When attaching the sensor mounts to painted or rusted pipes. File the areas of attachment in order to remove the paint or rust.

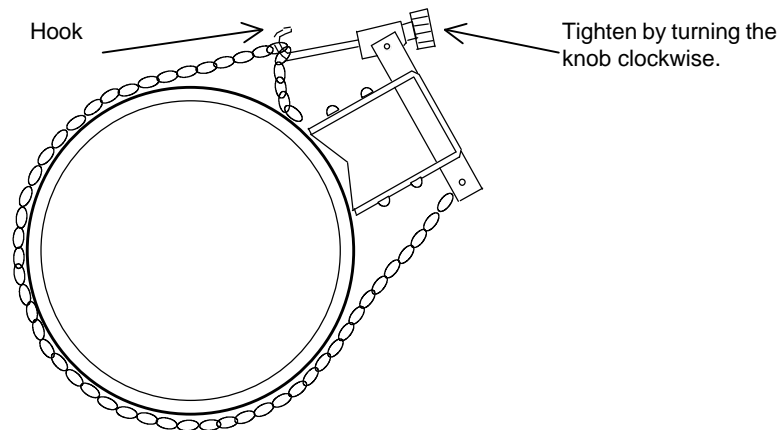


**Straight Alignment**



<b>Note:</b>
The length of straight pipe allows measurement where the fluid distribution is stable. In addition, the upper and lower areas are avoided because air bubbles can be present at the upper part of the pipe and sediment (impurities) can accumulate in the lower area, thus interfering with ultrasonic transmission and reception.

Fasten the sensor mounts by wrapping the mount chain around the pipe and hooking the end. Turn the hook knob to tighten the chain.



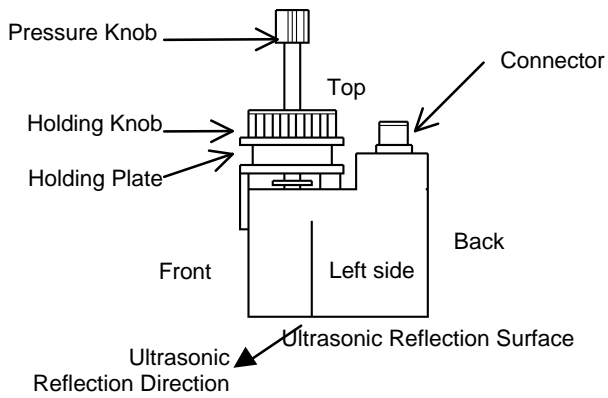
**Figure 3-7-4 Mount Attachment**

**Sensor Attachment**

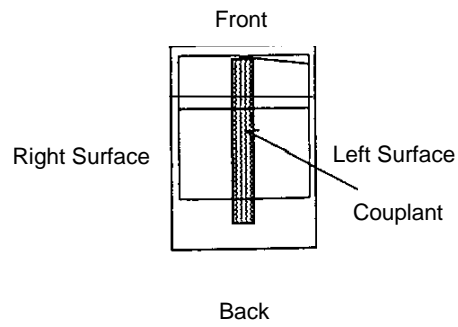
Refer to Section 4, "Input Mode Operation" and determine the sensor spacing. Apply couplant (silicon grease) in a vertical line to the ultrasonic reflector surface of the sensor with the cable attached.

Do not confuse upstream and downstream. Insert the sensor in the holes of the mount, such that the sensors face the ultrasonic reflectors.

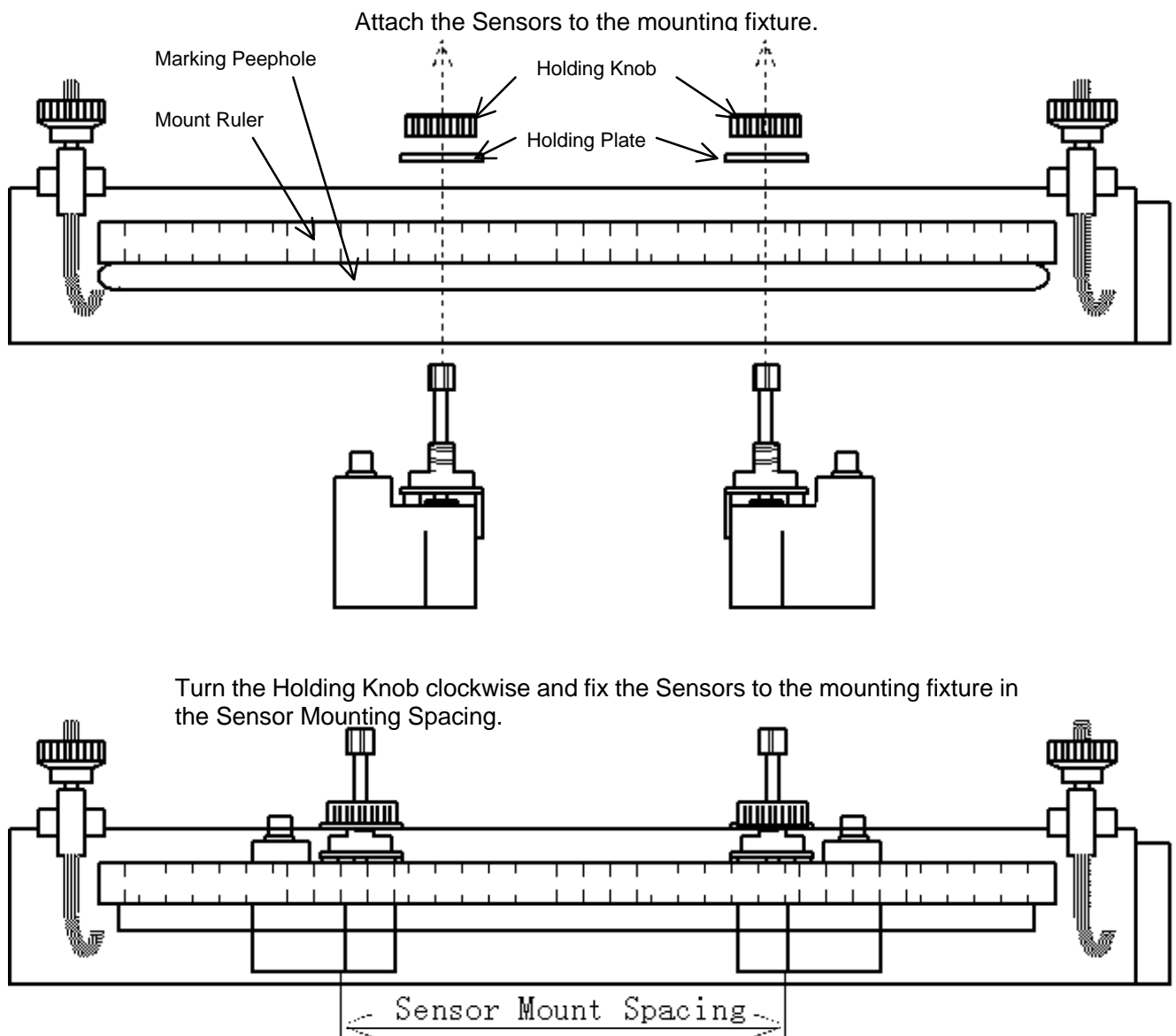
Use the ruler on the mounts to confirm the correct distance between the marks on the both sensors, and then affix the sensors.



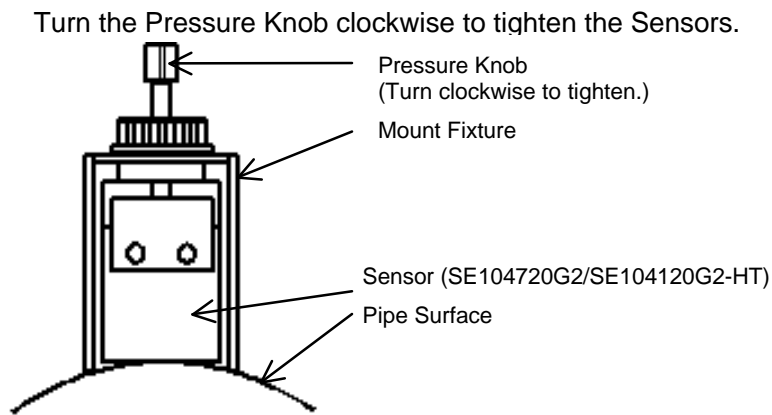
**Figure 3-7-5**  
**Sensor Ultrasonic Reflection Direction**



**Figure 3-7-6**  
**Couplant Application Front**

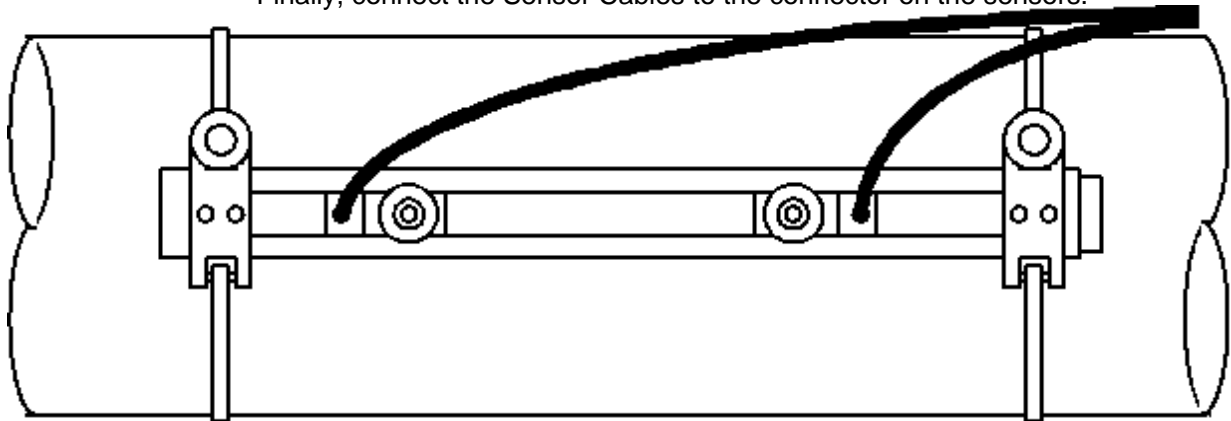


**Figure 3-7-7 Sensor Installation**



**Figure 3-7-8 Affixing the Sensor**

Finally, connect the Sensor Cables to the connector on the sensors.



**Figure 3-7-9 Sensor Mount After Attachment**

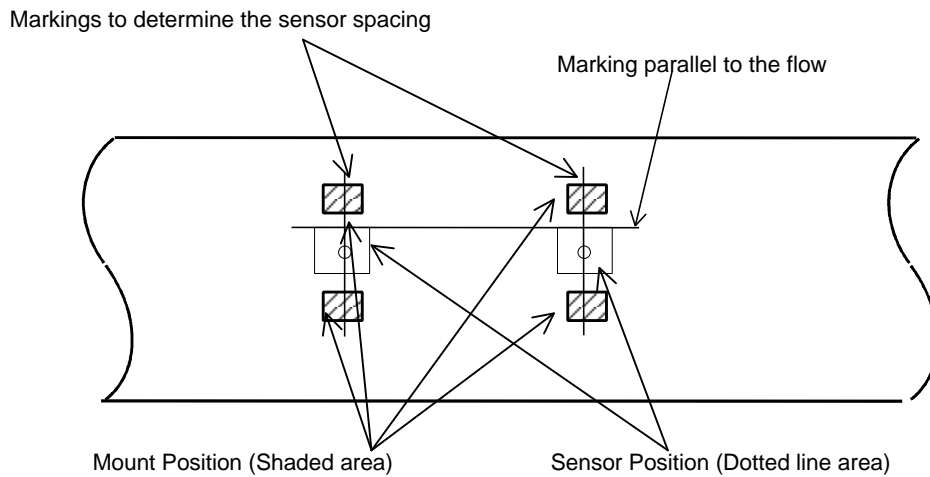
**Note:**

- The precision of the attachment greatly affects the precision of the measurement.
- When the required sensor distance is too wide to allow the sensors to be attached with one mount, use 2 mounts. In addition, use 2 mounts when using the Z or N attachment methods.

**(2) Large Sensor: SE044740G**

**Mount Set**

Position the large sensor under the same conditions as a standard sensor (for example straight length). Mark the pipe with a reference line for attaching the sensor. Wrap a roll of paper the width of the sensor attachment area parallels around the pipe to allow easy marking.



**Figure 3-7-10 Marking Method**

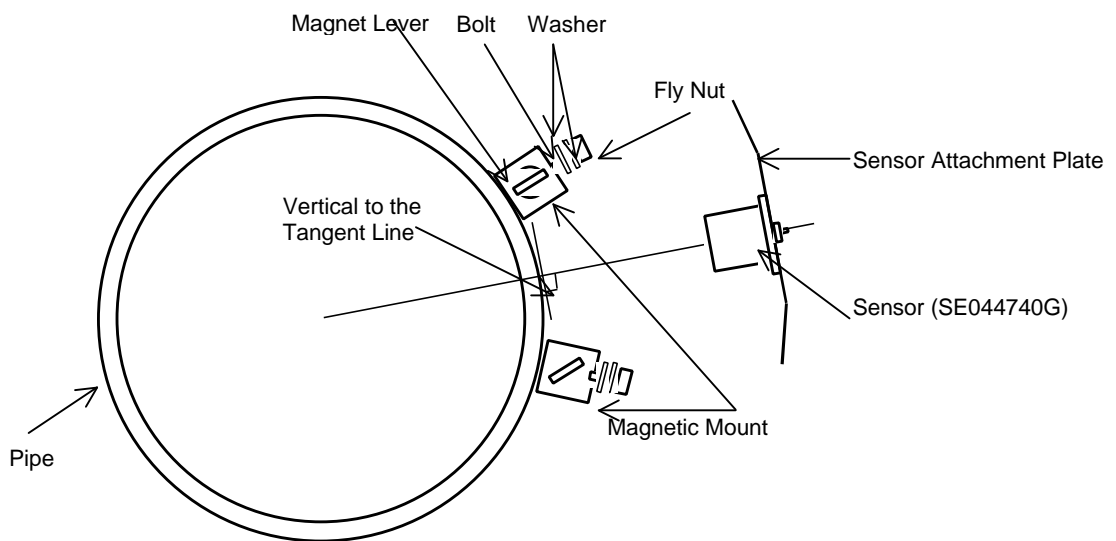
Attach the sensor such that the sensor spacing marking and those on both sides for the sensor sound radiation are aligned and the sensor side follows the marking parallel to the flow. In order to position the sensor correctly, it is important to calculate the appropriate position of the mount. Turning the lever on the side of the mount to the left activates a magnet. Turn the lever to the right, position the mount, and then turn the lever to the left. (4 locations)

**Sensor Attachment**

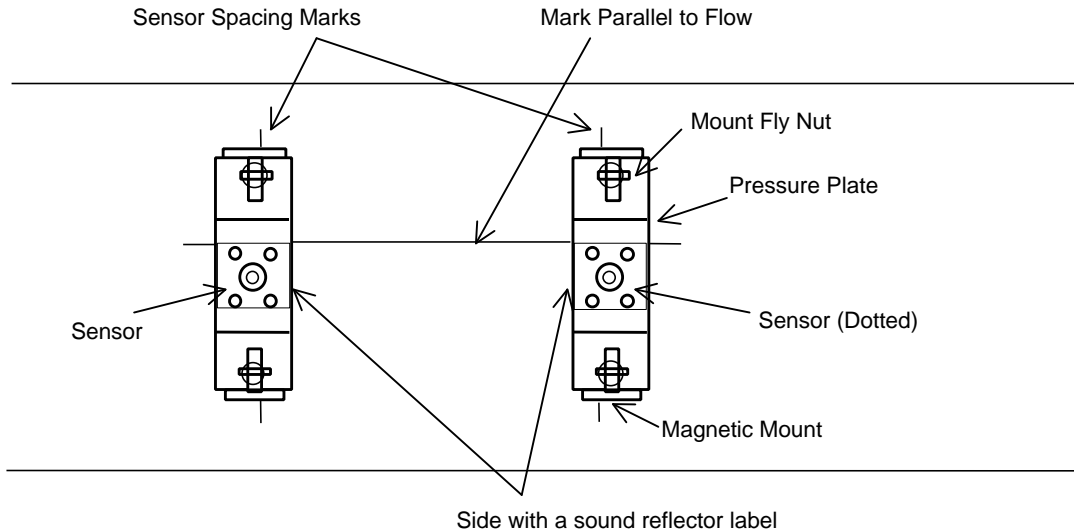
Apply couplant to the sensor in the same way as described for the standard sensor. Attach the sensors to the mount such that the sound radiation labels on the side of the sensors face each other. (Remove the fly nut and washer. Attach the mount plate over the bolts. Then, replace the washer and fly nut.) Attach the sensor vertically to the pipe tangent line. Tighten the fly nuts on both sides with even pressure.

**Note:**

The precision of the attachment directly affects the precision of the measurement.



**Figure 3-7-11 Sensor Attachment**



**Figure 3-7-12 Completed Sensor Mounting**

Finally, attach the sensor cable.

**Note:**

The magnetic mount is standard. Contact your Tokimec representative if the Tokimec magnets do not adhere to the surface of the pipe.

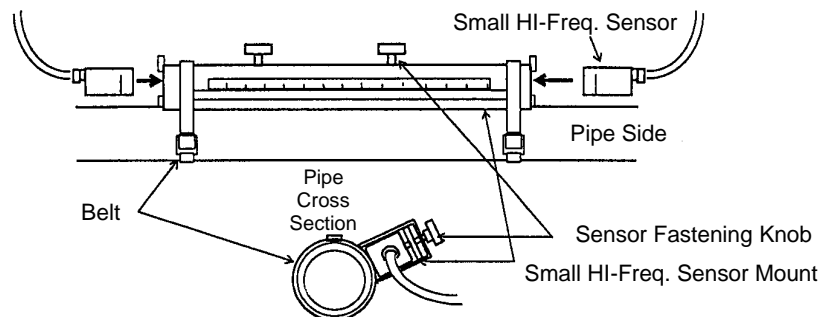
**(3) Small HI-Freq. Sensor: SE504110x10G**

**Mount Set**

Attach the small sensor mount to the pipe in the same manner as described for the standard sensor.

**Sensor Attachment**

Determine the sensor spacing in the same manner as described for the standard sensor. Attach the cables to the sensors and apply couplant as described for the standard sensor. Insert the sensors into both ends of the mount. Use the ruler on the mount to position the marks on the sound radiation plates to ensure correct spacing. Position the sensor fastening knobs over the sensor such that the axis fits into the sensor groove. Turn the knobs to the right to tighten.



**Figure 3-7-13 Small HI-Freq. Sensor Attachment**

#### (4) Thickness Meter Probe: TH5010G

The probe is used to measure thickness or fluid sound velocity.

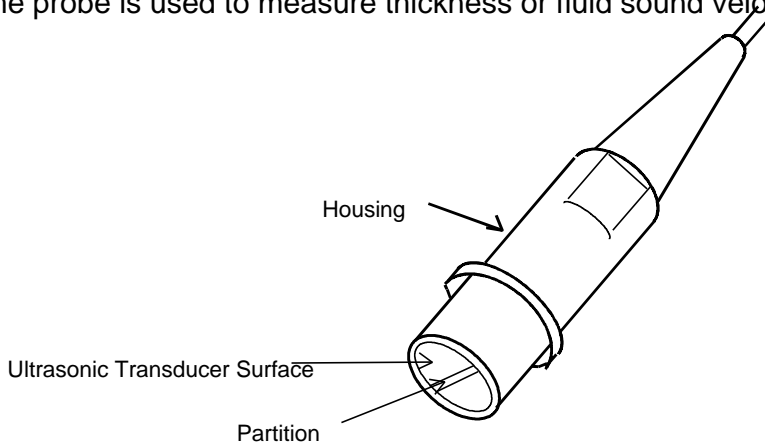


Figure 3-7-14

#### **Thickness Meter Calibration**

Calibration is necessary in order to use the UFP-10 as a thickness meter or sound velocity meter. Use the test piece (included) for calibration. Place the test piece on a flat surface with the round groove facing up. Apply Couplant to the ultrasonic transducer surface of the probe and press the surface on to the round inner surface of the test piece. Start calibration. Ensure that the probe does not move until the calibration is finished (in a few seconds).

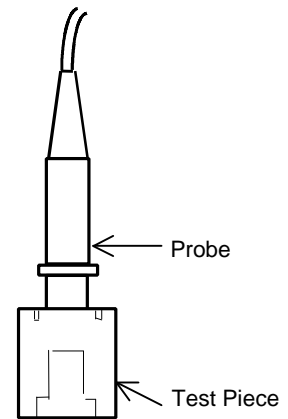


Figure 3-7-15  
Thickness Calibration

#### **Pipe Thickness Measurement**

Apply couplant liberally to the probe before performing the thickness measurement. Measure the thickness with the partition (on the transducer surface) at a right angle to the length of the pipe, and then parallel to the length of the pipe. Use the results from narrowest section.

Measurement is most stable with the partition at a right angle to the length of pipe. However, pipes that are thin or have a small diameter may appear thicker than they actually are. On the other hand, the measurement value is less stable when the partition is parallel. In this case, more accurate results are obtained for pipes that are thin or have a small diameter.

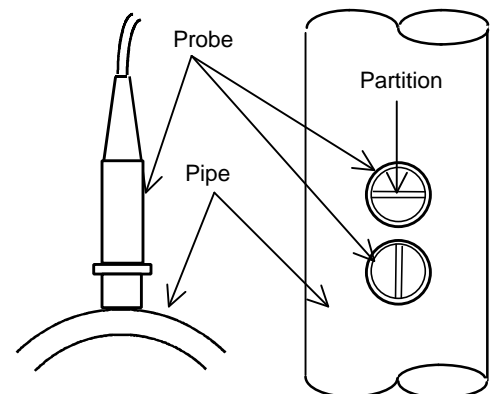
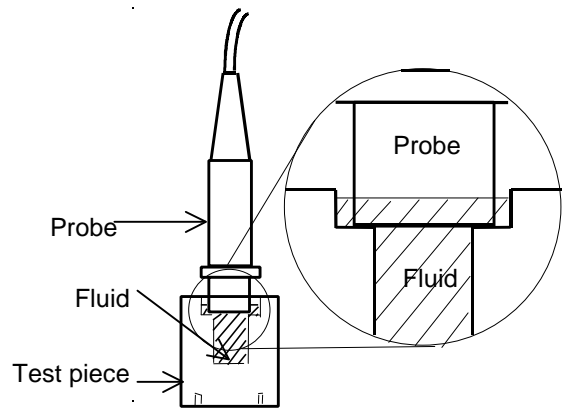


Figure 3-7-16  
Pipe Thickness Measurement

### ***Fluid Sound Velocity Measurement***

Fill the depressed section of the thickness test piece with the fluid. Cover the fluid with the ultrasonic transducer surface of the probe. Perform measurement, ensuring that the probe is vertical.

Do not apply couplant for this measurement. Correct measurement is not possible with couplant applied. Remove any couplant that may be present on the probe.



**Figure 3-7-17**  
**Fluid Sound Velocity Measurement**

**Note:**

Be particularly careful when measuring chemicals. Chemical residue in the test piece may cause burns if the residue contacts bare skin. In addition, the ultrasonic transducer surface is made of acrylic. Do not measure chemicals that will react with the transducer surface. Chemical reactions may generate toxic gases or heat.

# Section 4 Operation

---

## 4-1 Summary

This section explains various operations found on the UFP-10. Refer to Section 4-2, “Simple Measurements” for basic operations. More advanced operations are described from Section 4-3 onward. Detailed explanations are provided according to the operation mode. Refer to Section 7, “Term Designation” for an explanation of unfamiliar terms.

## 4-2 Simple Measurements

This section provides a general explanation and example of basic measurements. Users that require other functions should refer to the detailed operation explanation for each mode and the menu flow chart at the end of this manual. Basic operation is described according to the following general configuration.

### Pipe Specification

Material:	Steel
Nominal Diameter:	100A
Outer Diameter:	114.3 mm
Thickness:	4.0 mm
Lining:	None
Sensor:	Standards \ Sensor
Fluid:	Water
Cable Length:	10 m

Refer to page 4-9, “Figure 4-3 Operation Panel” to view the operation keys.

### (1) Turning Power ON to Start

Hold down the [ON] key until the following display appears. A self-diagnosis automatically starts.

```
HELLO!  
  
SELF CHECK  
      V 2 . 0 E  
RAM 1      OK  
RAM 2      OK  
RAM CHECK OK  
  
CNT CHECK OK
```

The following startup display appears if there are no problems. Use the [?] [?] keys or number keys to move the cursor to “ 3. Input”, and then press the [ENT] key.

```
STARTUP MENU
  SELECT NUMBERS
  1 : START MEAS .
  2 : GAIN SETTING
  3 : INPUT DATA
```

**(2) Pipe Data Input Start**

Pipe data and sensor select.

Press [ENT] after the following input confirmation.

```
INPUT
DATA INPUT

INPUT START
PLEASE CHECK
& PUSH [ENT]
```

**(3) Input Screen Selection**

Input or initialize select. Therefore, select 1, and then press [ENT] in this example.

```
INPUT FILE

FILE
  1 : INPUT
  2 : INIT ALL FILE
```

**(4) Pipe File Selection**

Designate the pipe file for use. Files 1 ~ 32 may be selected. The display below shows files 1 ~ 8. Use the [?][?][? ][? ] keys to move the cursor to the desired file, and then press [ENT].

```
INPUT FILE

SELECT FILE
1 : FILE 01
2 : FILE 02
3 : FILE 03
4 : FILE 05
5 : FILE 06
7 : FILE 07
8 : FILE 08
```

**(5) Pipe File Name Input**

A name can be added to the pipe file. Use the [?][?][? ][? ] keys to move the cursor to the desired letters. Select one letter at a time, and then press [ENT] after each selection. Press [CLR] when you erase a character. Press [SHFT] and [ENT] when you finish input. A repeat can work with [?][?][? ][? ] [CLR] keys.

```
INPUT
FILE NAME

# 01 FILE 01__

! " # $ % & ' ( ) * + , - . /
0 1 2 3 4 5 6 7 8 9 : ; < = > ?
@ A B C D E F G H I J K L M N O
P Q R S T U V W X Y Z [ \ ] ^ _
` a b c d e f g h i j k l m n o
p q r s t u v w x y z { | }
. « » , .

PRESS SHFT AND
ENT TO FINISH
```

**(6) Pipe Type Input**

Designate the type of pipe to be used. A normal pipe is used in this example. Therefore, select “ 1: Normal Pipe. “

```
INPUT

TYPE OF PIPE
1 : NORMAL PIPE
2 : MEAS. PIPE

# 01 FILE 01
```

**(7) Pipe Size Input Way**

Input way the size of the pipe. Therefore, select 1, and then press [ENT].

```
INPUT
OUTER DIA. / CIRC.
 1 : DIAMETER
 2 : CIRCUMFERENCE

# 0 1   F I L E   0 1
```

**(8) Pipe Outer Diameter Input**

Input the outer diameter of the pipe. The previously input value or the factory set value appears on the display as shown below. Input the correct value. Press [CLR] to delete the displayed value. The pipe diameter is measured in “mm” in this example.

```
INPUT
DIAMETER
 1 : 1 1 4 . 3 _   mm

# 0 1   F I L E   0 1
```

**(9) Pipe Material Input**

Input the pipe material. The display shows materials 1~7. In this example the material is steel. Therefore, select 1, and then press [ENT].

```
INPUT
PIPE MATERIALS
 1 STEEL
 2 : DUCTILE IRON
 3 : CAST IRON
 4 : STAINLESS ST.
 5 : VINYL CHLORI.
 6 : FRP
 7 : ACRYLIC
 8 :                               m / s

# 0 1   F I L E   0 1
```

### (10) Pipe Thickness Input

Input the thickness of the pipe used. The thickness stored in memory is displayed. Input the correct pipe thickness. To delete the displayed value, press [CLR]. After the correct value has been input, press [ENT]. The measurement unit is “ mm” in this example.

```
INPUT
PIPE THICKNESS
1: 4.0_ mm
# 0 1   FILE 0 1
```

### (11) Pipe Lining Input

Input the pipe lining material. Select from either “ NON” or the other three linings shown. In addition, the sound velocity of the material can be set. In this example, there is no lining. Therefore, select No. 1 “ NON”. Press [ENT] after selecting.

```
INPUT
LINING MATERIALS
1: NON
2: TAR EPOXY
3: MORTAR
4: RUBBER
5:           m / s
# 0 1   FILE 0 1
```

### (12) Fluid Input

Input the type of fluid to be measured. The display shows “ WATER” and “ SEA WATER”. Select 1 “ WATER” for this example.

```
INPUT
FLUID
1: WATER
2: SEA WATER
3:           m / s
# 0 1   FILE 0 1
```

**(13) Sensor Input**

Input the type of sensor to be used. The standard sensor is used in this example. Select 1: "STANDARD".

```
INPUT
KIND OF SENSOR
1: STANDARD
2: LARGE
3: HI - TEMP
4: SMALL HI - FREQ
5: OTHERS
6: SMALL LO - FREQ

# 0 1   F I L E   0 1
```

**(14) Sensor Attachment method**

Input the sensor attachment method. In this example, the V method is used. Select 2: "V METHOD".

```
INPUT
SENSOR INSTALL
1: Z METHOD
2: V METHOD
3: N METHOD
4: W METHOD
5: W+Z METHOD

# 0 1   F I L E   0 1
```

**(15) Sensor Mount Distance**

The appropriate distance is calculated and displayed according to the data input above. Attach the sensors at the distance shown. (Refer to Section 3 for the attachment procedure.) Press [ENT] to proceed to the next item after confirming the distance.

```
INPUT
SENSOR DISTANCE
1: 104.3 mm

# 0 1   F I L E   0 1
```

**(16) Cable Length Input**

Input the length of the cable that connects the unit to the sensors. The standard cable is used in this example. Therefore, input 10.0.

```
INPUT
CABLE LENGTH
1: 10.0 mm
# 01 FILE 01
```

**(17) Transmission Power Input**

Input the sensor transmission power. Usually 1: "LOW" is selected.

```
INPUT
TRANSMITTING POW
1: LOW
2: HIGH
# 01 FILE 01
```

**(18) Flow Measurement Unit**

Designate a unit for measurement to be used. The displayed units are different according to your selected unit system in "UNIT SELECT" display.

```
INPUT
MEASURING UNIT
1: m3/h
2: m3/min
3: m3/s
4: m3/D
# 01 FILE 01
```

[METRIC]

```
INPUT
MEASURING UNIT
1: ft3
2: gal
3: bbl
4: acf
# 01 FILE 01
```

[USA]

Skip over (19) and see (20) when you use metric system.

**(19) Flow Measurement Unit for USA system**

Select another measurement unit if you use USA system. (Skip (20) when you use metric system.)

```
INPUT
MEASURING UNIT
1: ft3/h
2: ft3/min
3: ft3/s
4: ft3/D
5: Mft3/D
#01 FILE 01
```

[when "ft3" selected]

$$1[\text{ft}^3] = 0.0283168[\text{m}^3]$$

```
INPUT
MEASURING UNIT
1: gal/h
2: gal/min
3: gal/s
4: gal/D
5: Mgal/D
#01 FILE 01
```

[when "gal" selected]

$$1[\text{gal}] = 0.00378541[\text{m}^3]$$

```
INPUT
MEASURING UNIT
1: bbl/h
2: bbl/min
3: bbl/s
4: bbl/D
5: Mbbl/D
#01 FILE 01
```

[when "bbl" selected]

$$1[\text{bbl}] = 0.119240[\text{m}^3]$$

```
INPUT
MEASURING UNIT
1: acf/h
2: acf/min
3: acf/s
4: acf/D
5: Macf/D
#01 FILE 01
```

[when "acf" selected]

$$1[\text{acf}] = 1233.482[\text{m}^3]$$

**(20) Automatic Gain Adjustment Start**

Item 16 completes the pipe data input. Next, Automatic Gain Adjustment is performed. Press [SHFT] (an "S" appears in the upper right section of the display), and then press [Flow].

```
INPUT
INPUT END. PUSH
[SHFT] & [FLOW]
PLEASE SET GAIN
#01 FILE 01
```

**(21) Automatic Gain Adjustment**

Automatic Gain Adjustment is performed. Confirm that the sensors are correctly attached to the pipe, and then press [ENT]. The gain is automatically measured.

```
GAIN
AUTO GAIN
GAIN SETTING
CHECK SENSORS
PUSH [ENT]

# 0 1   F I L E   0 1
```

### 4-3 Operation Panel

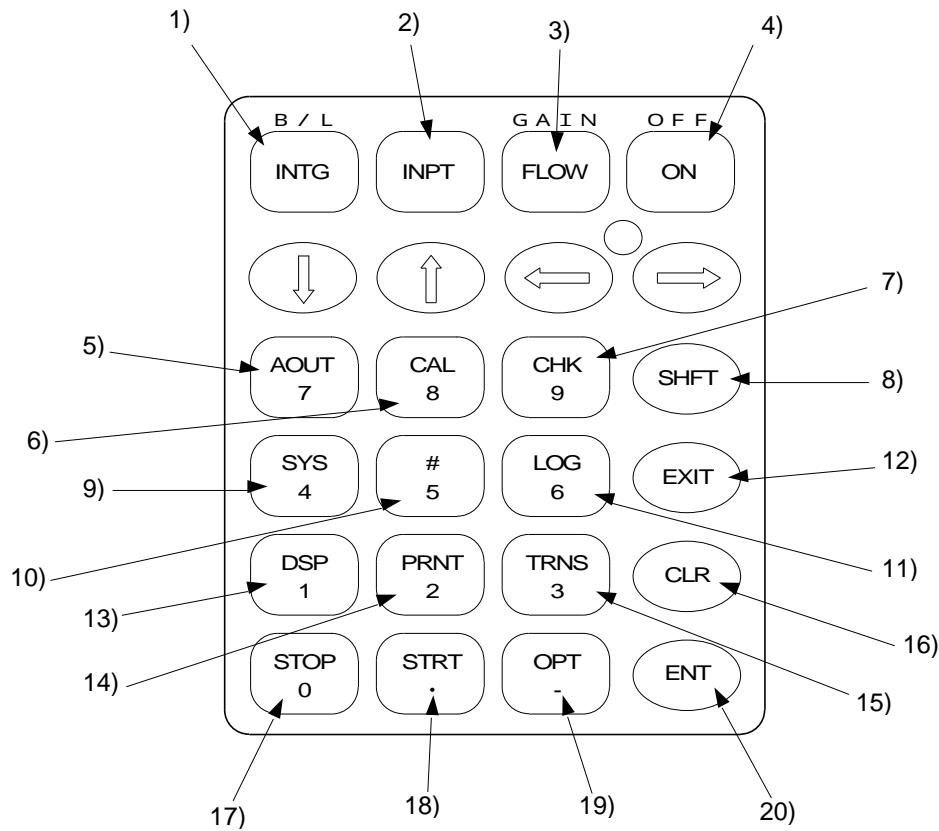


Figure 4-3 Operation Panel

1)	Integration Mode/Backlight Switch (S)	11)	Log Mode (S)/Number 6 key
2)	Pipe data input mode	12)	Return key (To go back to previous step)
3)	Flow meter/Gain Set (S)	13)	Display Type Set (S)/Number 1 key
4)	Power On/Off (S)	14)	Print Set (S)/Number 2 key
5)	Analog Output (S)/Number 7 Key	15)	Digital Output Set (S)/Number 3 key
6)	Output Calibration (S)/Number 8 key	16)	Input Value Clear
7)	Setup Check (S)/Number 9 key	17)	Integration Stop/Number 0 key
8)	Shift Key	18)	Integration Start/ “ . ” key
9)	System Set (S)/Number 4 key	19)	Option Function/ “ - ” key
10)	Number 5 key	20)	ENT key (To decide item)

## 4-4 Startup Check

Confirm the following before starting up the UFP-10:

- (1) Confirm that the environment is suitable for operation. In particular, check for flammable gas.
- (2) Confirm that the power source is adequate and correctly connected.
- (3) Confirm that the sensors are correctly connected.

## 4-5 Startup

Startup the UFP-10 after confirmation is complete according to the following steps:

- (1) Hold down the [ON] key until the power comes on.
- (2) The following self-diagnosis display will appear. Confirm that there are no problems.

```
HELLO!  
  
SELF CHECK  
V 2 . 0 E  
  
RAM 1          OK  
RAM 2          OK  
RAM CHECK OK  
  
CNT CHECK OK
```

- (3) The following startup menu will appear if there are no problems. Use the [?] [?] keys to move the cursor to the desired item, and then press [ENT].

```
STARTUP MENU  
SELECT NUMBERS  
1 : START MEAS .  
2 : GAIN SELECT  
3 : INPUT DATA
```

? Flow measure start  
? Automatic gain adjustment  
? Pipe data input

- (4) If the self-diagnosis function (RAM1, RAM2, CNT) detects a problem in the Hardware, the procedure will stop. Contact your Tokimec representative. Press [Shift] and then [ON] to turn the power off. If the self-diagnosis function (RAM CHECK) detects unsuitable data, the system sets initial data and goes on the procedure.
- (5) When startup, you can reset Pipe data and system data except LOG data to the initial value according to the following procedure:
  - Hold down the [ON] and [0] key to startup the UFP-10.
  - Stop holding down the [ON] after "HELLO!" message appears on the screen, and stop holding down the [0] after "ALL RAM INIT" message.

## 4-6 Flowmeter Display (FLOW Mode)

Select 1: "START MEAS." from the startup display to enter the flow measurement mode. The previously set or factory set UFP-10 pipe data is automatically used in this mode. The flow measurement display is shown below.

When [FLOW] key is pressed in other mode, it returns to this FLOW mode.

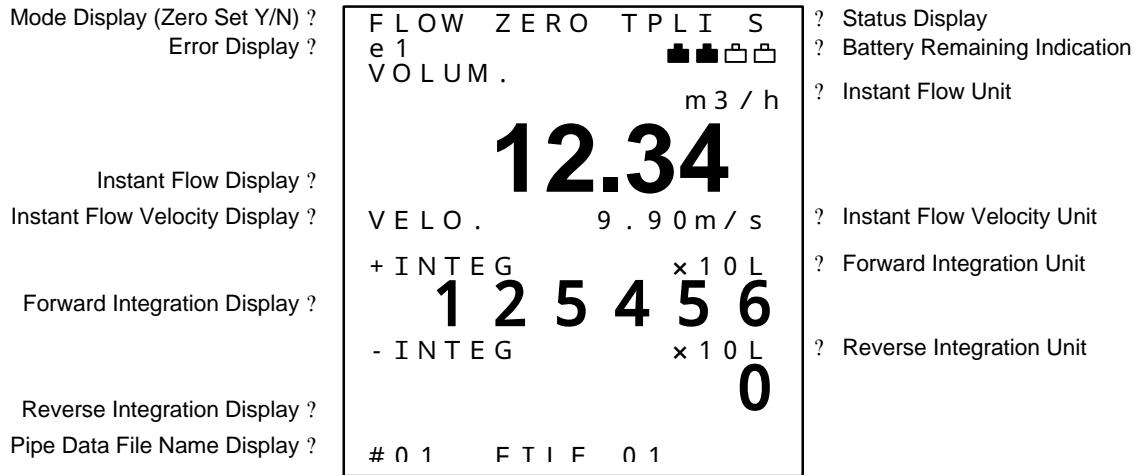




Figure 4-6 Display

### Each Display:

Mode Display-The currently selected mode is displayed. The following modes are available:






	Display	Content
1)	INTEG	Integration Set
2)	INPUT	Pipe Data Input
3)	FLOW	Flow Measurement (No zero set)
	FLOW ZERO	Flow Measurement (With zero set)
4)	GAIN	Adjustment
5)	A-OUT	Analog Output Set
6)	CAL	Various Adjustments (Analog Output Adjustment, Compensation Coefficient Set)
7)	CHECK	User Set Confirmation
8)	SYS	System Set
9)	LOG	Logging Set
10)	DISPLAY	Display Set
11)	PRINT	Print Set
12)	TRANS	Digital Output Set
13)	OPT	Option Function (Thickness Meter, Sound Velocity Measurement, Pipe Display)

**Status Display:** The current measurement and output conditions are displayed in real-time.

Display	Condition
1) T	Digital data output to a computer.
2) P	Data output to printer
3) L	Measurement Data Logging
4) 	Measurement Data Logging Stand by
5) I	Flow Integration
6) 	Flow Integration Stand by
7) No Display	Normal Measurement
8) S	SHFT function available

**Error Display:** An Error Code (refer to Appendix F) is displayed if an error occurs during measurement.

**Battery Level Indicator:** Displays the power remaining in the battery and backup battery.

	Completely charged
  	Intermediate Levels
	The battery will run out in approximately 20 minutes

**Instantaneous Flow Rate:** Instantaneous flow rate is displayed in “ VOLUM. “ area. The unit is shown over the number and it is determined automatically by the inside diameter of the pipe. When the flow velocity is over 20m/s (overflow), it is displayed like as “ -----”.

**Instantaneous Flow Velocity Display:** Instantaneous flow velocity is displayed in “ VELO. “ area. The unit is [m/s] and it is shown right side of the number. When the flow velocity is over 20m/s (overflow), it is displayed like as “ -----”.

**Integration Value Display:** Forward integration value is displayed in “ +INTEG” area and reverse integration value is displayed in “ -INTEG” area. The unit is shown over the number and selected in the INTEG mode. When the flow velocity is over 20m/s (overflow), it is displayed like as “ -----”.

**Pipe data File Name Display:** The selected Pipe data File number and name of the file are displayed in the lowest line on the screen.

The codes in front of the number have the following meaning:

<b>Display</b>	<b>Meaning</b>
1) #OO	Ordinary flow measurement (1 file is used for measurement on 1 line.)

**Note:**

- The pipe data and gain will not be set automatically when 1: "START MEAS." is selected from the startup display. To avoid inaccurate measurements, select 3: "INPUT DATA", confirm the pipe data, start AGA to set the gain, and then designate the measurement mode.

-----  
-  
Hint (Flow rate)

When the number is " 12.34" and the unit is " E-3 m3/m", the flow rate is 0.01234 [m3/m]. And it is equal to 12.34 [L/m].

" E-3" in front of the unit means "  $\times 10^{-3}$ " ( $\times 0.001$ ).

" E-6" in front of the unit means "  $\times 10^{-6}$ " ( $\times 0.000001$ ).

" E+3 in front of the unit means "  $\times 10^3$ " ( $\times 1000$ ).

## INPUT Mode Operation

Data used for measurement such as pipe data, the measurement method, and the display units are designated in the “INPUT Mode”.

The INPUT Mode can be designated by one of the following methods:

- 1) Select 3: “INPUT DATA” from the startup menu.
- 2) Press [INPT] in the FLOW Mode.

During inputting pipe data in this mode, it returns to FLOW mode by pressing [FLOW] key. And then the set data before pressing [FLOW] are available.

The following explanation describes the various input items and displays:

<i>Display</i>	<i>Explanation</i>	<i>Input Operation</i>
<pre> INPUT DATA INPUT INPUT START PLEASE CHECK &amp; PUSH [ENT]           </pre>	<p>(1) Input Mode Initial Display</p> <p>Perform the operation to the right to change the pipe file used in the measurement.</p> <p>Then, proceed to (2).</p>	<p>To change the pipe file:</p> <p>- [ENT]</p> <p>Return to FLOW mode without changing the pipe file:</p> <p>- [FLOW]</p>
<pre> INPUT FILE FILE 1: INPUT 2: INIT ALL FILE           </pre>	<p>(2) Input Screen Selection</p> <p>Select input screen “1:INPUT” or, “2:INIT ALL FILE”.</p> <p>Press 1, and proceed to step (3), or</p> <p>Press 2, and proceed to step (22).</p>	<p>Press [?] to move the cursor up.</p> <p>Press [?] to move the cursor down.</p> <p>Press the item number for direct selection.</p> <p>Press [ENT] to set</p>

<b>Display</b>	<b>Explanation</b>	<b>Input Operation</b>
<pre> INPUT  SELECT FILE  1 : FILE 01  2 : FILE 02  3 : FILE 03  4 : FILE 04  5 : FILE 05  6 : FILE 06  7 : FILE 07  8 : FILE 08 </pre>	<p>(3) Designate the file number to be used.</p> <p>The cursor appears at the file presently in use. Proceed to the next step to keep the same file. The [?] [?] keys can also be used to move between pages. 8 files are displayed on each page.</p>	<p>Press [?] to move to the next page.</p> <p>Press [?] to move to the previous page.</p> <p>Press [?] to move the cursor up.</p> <p>Press [?] to move the cursor down.</p> <p>Press [ENT] to set.</p>
<pre> INPUT FILE NAME  # 0 1 FILE 0 1 _  ! " # \$ % &amp; ' ( ) * + , - . / 0 1 2 3 4 5 6 7 8 9 : ; &lt; = &gt; ? @ A B C D E F G H I J K L M N O P Q R S T U V W X Y Z [ \ ] ^ _ ` a b c d e f g h i j k l m n o p q r s t u v w x y z {   } . , ' , ` .  PRESS SHFT AND ENT TO FINISH </pre>	<p>(4) Pipe Data File Name Input. The current file name appears at the upper side of the display. If no change is needed, press [SHFT] &amp; [ENT] and advance to step (5). To change the file name, move the cursor to the input character, and press [ENT]. Repeat this procedure for each character in the file name.</p> <p>Press [CLR] when you erase a character.</p> <p>Press [SHFT] and [ENT] when you finish input.</p> <p>A repeat can work with [?] [?] [?] [?] [CLR] keys.</p>	<p>Press [?] to move the cursor right.</p> <p>Press [?] to move the cursor left.</p> <p>Press [?] to move the cursor up.</p> <p>Press [?] to move the cursor down.</p> <p>Press [ENT] to set each character.</p> <p>Press [CLR] to erase character.</p> <p>Press [SHFT] and [ENT] when you finish input.</p>

<b>Display</b>	<b>Explanation</b>	<b>Input Operation</b>
<pre> INPUT  TYPE OF PIPE  1: NORMAL PIPE  2: MEAS. PIPE  # 0 1   F I L E   0 1 </pre>	<p>(5) Select the type of pipe to be measured.</p> <p>The cursor appears at the currently designated pipe type. Move the cursor to the desired pipe type, and press [ENT]</p> <p>Press 1, and proceed to step (6), or Press 2, and proceed to step (12).</p> <p><b>Note:</b> Item2 "Measuring Pipe" is for special usage. NOT to be selected.</p>	<p>Press [?] to move the cursor up.</p> <p>Press [?] to move the cursor down.</p> <p>Press the item number for direct selection.</p> <p>Press [ENT] to set.</p>
<pre> INPUT  OUTER DIA. / CIRC.  1: DIAMETER  2: CIRCUMFERENCE  # 0 1   F I L E   0 1 </pre>	<p>(6) Input the size of the pipe way. 1 is selected when it knows diameter. 2 is selected when it knows circumference.</p> <p>Select the way to input pipe size.</p> <p>" 1" should be selected when diameter is known.</p> <p>" 2" should be selected when circumference is known.</p>	<p>Press [?] to move the cursor up.</p> <p>Press [?] to move the cursor down.</p> <p>Press the item number for direct selection.</p> <p>Press [ENT] to set .</p>
<p>[when " DIAMETER" selected]</p> <pre> INPUT  OUTER DIAMETER  1: 1 1 4 . 3   mm  # 0 1   F I L E   0 1 </pre> <p>[when " CIRCUMFERENCE" selected]</p> <pre> INPUT  CIRCUMFERENCE  1: 1 1 4 . 3   mm  # 0 1   F I L E   0 1 </pre>	<p>(7) Input the size of the pipe to be measured.</p> <p>The underline cursor is located at the first digit of the current pipe dimension.</p> <p>To change the dimensions, input a new value over the old value, or press [CLR] to clear the display before inputting the new value.</p> <p>Or, press [ENT] to advance to the next step (8) without changing the dimension or after completing of the value input.</p>	<p>Press [? ] to move the cursor right.</p> <p>Press [? ] to backspace.</p> <p>Press number keys to input a number.</p> <p>Press [CLR ] to clear the display.</p> <p>Press [ENT] to set.</p>

<i>Display</i>	<i>Explanation</i>	<i>Input Operation</i>
<pre> INPUT  PIPE MATERIALS 1: STEEL 2: DUCTILE IRON 3: CAST IRON 4: STAINLESS ST. 5: VINYL CHLORI. 6: FRP 7: ACRYLIC 8:                               m / s  # 0 1   FILE 0 1 </pre>	<p>(8) Input the pipe material or sound velocity.</p> <p>Select the appropriate pipe material from items 1 -7. The sound velocity shown to the right of the object is used.</p> <p>Select item 8 if the pipe material is not shown in items 1 -7, or the sound velocity differs. The current sound velocity is displayed. Press [CLR] to clear the value, and then use the cursor to select a new value. Press [ENT] to set.</p>	<p>Press [?] to move the cursor up.</p> <p>Press [?] to move the cursor down.</p> <p>Press number keys to directly input a number.</p> <p>Press number keys to input sound velocity.</p> <p>Press [CLR ] to clear the display.</p> <p>Press [ENT] to set each character.</p>
<pre> INPUT  PIPE THICKNESS 1: 4_                               mm  # 0 1   FILE 0 1 </pre>	<p>(9) Set the pipe thickness.</p> <p>The underline cursor appears at the first digit of the current pipe thickness.</p> <p>To change the dimensions, input a new value over the old value, or press [CLR] to clear the display before inputting the new value.</p> <p>Or, press [ENT] to advance to the next step without changing the dimension.</p>	<p>Press [? ] to move the cursor right.</p> <p>Press [? ] to backspace.</p> <p>Press number keys to input a number.</p> <p>Press [CLR ] to clear the display.</p> <p>Press [ENT] to set.</p>
<pre> INPUT  LINING MATERIALS 1: NON 2: TAR EPOXY 3: MORTAR 4: RUBBER 5:                               m / s  # 0 1   FILE 0 1 </pre>	<p>(10) Input the pipe lining material or sound velocity. Select the appropriate lining from items 1 - 4. Select item 5 if the material is not shown in items 1 -4, or the sound velocity is different. The current sound velocity is displayed.</p> <p>press [CLR] to clear the value, and then use the cursor to select a new value. Press [ENT] to set.</p> <p>Proceed to step (12) if there is no lining, or else proceed to step (11).</p>	<p>Press [?] to move the cursor up.</p> <p>Press [?] to move the cursor down.</p> <p>Press number keys to directly input a number.</p> <p>Press number keys to input sound velocity.</p> <p>Press [CLR] to clear the display.</p> <p>Press [ENT] to set each character.</p>

<b>Display</b>	<b>Explanation</b>	<b>Input Operation</b>
<pre> INPUT LINING THICKNESS  1 : 1 . 4 _ mm # 0 1 FILE 0 1 </pre>	<p>(11) Input the lining thickness.</p> <p>The underline cursor appears at the first digit of the current pipe dimension.</p> <p>To change the dimensions, input a new value over the old value, or press [CLR] to clear the display before inputting the new value.</p> <p>Or, press [ENT] to advance to the next step without changing the dimension.</p> <p>Proceed to step (12) after completing the set.</p>	<p>Press [?] to move the cursor right.</p> <p>Press [?] to backspace.</p> <p>Press number keys to input a number.</p> <p>Press [CLR] to clear the display.</p> <p>Press [ENT] to set.</p>
<pre> INPUT FLUID  1 : WATER  2 : SEA WATER  3 : m / s # 0 1 FILE 0 1 </pre>	<p>(12) Input the sound velocity of the fluid to be measured.</p> <p>The sound velocity is set at 1460 m/s if "1: WATER" is selected.</p> <p>The sound velocity is set at 1510 m/s if "2: SEA WATER" is selected.</p> <p>Select item 3 for other fluids or different sound velocity.</p> <p>The current sound velocity is displayed. Press [CLR], and then use the cursor to input a new sound velocity. Press [ENT] to set the new value.</p> <p>Select 1 or 2, and then proceed to step (14), or</p> <p>Select 3, and then proceed to step (13).</p>	<p>Press [?] to move the cursor up.</p> <p>Press [?] to move the cursor down.</p> <p>Press number keys to directly input a number.</p> <p>Press number keys to input a number.</p> <p>Press [CLR] to clear the display.</p> <p>Press [ENT] to set.</p>
<pre> INPUT VISCOSITY  1 : STANDARD  2 : cm 2 / s # 0 1 FILE 0 1 </pre>	<p>(13) Input the fluid kinematic viscosity coefficient.</p> <p>Select item 1 "STANDARD" for automatic 0.012 cm<sup>2</sup>/s input.</p> <p>Select item 2 for any other input. In this case, press [CLR] to clear the present kinematic viscosity coefficient from the display, and then input the new kinematic viscosity coefficient. Press [ENT].</p> <p>Proceed to step (14).</p>	<p>Press [?] to move the cursor up.</p> <p>Press [?] to move the cursor down.</p> <p>Press number keys to directly input a number.</p> <p>Press number keys to input a number.</p> <p>Press [CLR] to clear the display.</p> <p>Press [ENT] to set.</p>

<i>Display</i>	<i>Explanation</i>	<i>Input Operation</i>
<pre> INPUT  KIND OF SENSOR 1 : STANDARD 2 : LARGE 3 : HI - TEMP 4 : SMALL HI - FREQ 5 : OTHERS 6 : SMALL LO - FREQ  # 0 1   F I L E   0 1 </pre>	<p>(14) Set the sensor type.</p> <p>The cursor appears at the current sensor. Select another sensor as required, or press [ENT] to keep the current sensor and advance to the next step.</p> <p><b>Note:</b> Item5 “OTHERS” is for special usage of auxiliary sensor . NOT to be selected.</p>	<p>Press [?] to move the cursor up.</p> <p>Press [?] to move the cursor down.</p> <p>Press [ENT] to set.</p>
<pre> INPUT  SENSOR INSTALL. 1 : Z METHOD 2 : V METHOD 3 : N METHOD 4 : W METHOD 5 : W+Z METHOD  #01   F I L E   0 1 </pre>	<p>(15) Select sensor mount method.</p> <p>Normally the V method is used. Use the Z method when measurement is not possible with the V method.</p> <p>N, W, and W+Z are auxiliary methods. As the number of ultrasonic pulse reflections increase, the loss increases and the reception signal level decreases.</p>	<p>Press [?] to move the cursor up.</p> <p>Press [?] to move the cursor down.</p> <p>Press number keys to directly input a number.</p> <p>Press [ENT] to set.</p>
<pre> INPUT  SENSOR DISTANCE 1 : 1 0 4 . 3 _      mm  # 0 1   F I L E   0 1 </pre>	<p>(16) The sensor mount spacing is calculated and displayed.</p> <p>Align the sensor mounts at the proper spacing.</p>	<p>Press [ENT] to set.</p> <p>Press [?] to backspace.</p> <p>Press number keys to input a number.</p> <p>Press [CLR ] to clear the display.</p> <p>Press [ENT] to set numbers.</p>

<b>Display</b>	<b>Explanation</b>	<b>Input Operation</b>
<pre> INPUT CABLE LENGTH 1: 10.0__ m # 0 1   FILE 0 1 </pre>	<p>(17) Input the cable length. The standard cable is 10 m.</p> <p>If select 6 "SMALL LO-FREQ" in (14), then proceed to (18). Otherwise proceed to (19).</p>	<p>Press [?] to move the cursor right.</p> <p>Press [?] to backspace.</p> <p>Press number keys to input a number.</p> <p>Press [CLR] to clear the display.</p> <p>Press [ENT] to set numbers.</p>
<pre> INPUT TRANSMITTING POW 1: LOW 2: HIGH # 0 1   FILE 0 1 </pre>	<p>(18) Select the transmitting power. This item is required only for "SMALL LO-FREQ".</p> <p>Normally use the LOW setting. Use HIGH only when the ultrasonic pulse strength drops so low that adequate reception sensitivity cannot be achieved.</p>	<p>Press [?] to move the cursor up.</p> <p>Press [?] to move the cursor down.</p> <p>Press number keys to directly input a number.</p> <p>Press [ENT] to set.</p>

<b>Display</b>	<b>Explanation</b>	<b>Input Operation</b>
<p>[when "METRIC" selected]</p> <pre> INPUT MEASURING UNIT 1:m3/h 2:m3/min 3:m3/s 4:m3/D  #01 FILE 01 </pre> <p>[when "USA" selected]</p> <pre> INPUT MEASURING UNIT 1:ft3 2:gal 3:bb1 4:acf  #01 FILE 01 </pre>	<p>(19) Select a measuring unit to be used on the display.</p> <p>The displayed units are different according to your selected unit system in "UNIT SELECT" of SYSTEM mode.</p> <p>Skip over (20) and see (21) when you use metric system.</p>	<p>Press [?] to move the cursor up.</p> <p>Press [?] to move the cursor down.</p> <p>Press number keys to directly input a number.</p> <p>Press [ENT] to set.</p>
<p>[when "ft3" selected]</p> <pre> INPUT MEASURING UNIT 1:ft3/h 2:ft3/min 3:ft3/s 4:ft3/D 5:Mft3/D  #01 FILE 01 </pre> <p>[when "gal" selected]</p> <pre> INPUT MEASURING UNIT 1:gal/h 2:gal/min 3:gal/s 4:gal/D 5:Mgal/D  #01 FILE 01 </pre>	<p>(20) Select further measuring unit if you use USA system. (Skip (21) when you use metric system.)</p> <p><b>Note:</b></p> <p>1[ft<sup>3</sup>] = 0.0283168[m<sup>3</sup>]  1[gal] = 0.00378541[m<sup>3</sup>]  1[bb1] = 0.119240[m<sup>3</sup>]  1[acf] = 1233.482[m<sup>3</sup>]</p>	<p>Press [?] to move the cursor up.</p> <p>Press [?] to move the cursor down.</p> <p>Press number keys to directly input a number.</p> <p>Press [ENT] to set.</p>

[when "bbl" selected]

INPUT

MEASURING UNIT

- 1: bbl/h
- 2: bbl/min
- 3: bbl/s
- 4: bbl/D
- 5: Mbbl/D

#01 FILE 01

[when "acf" selected]

INPUT

MEASURING UNIT

- 1: acf/h
- 2: acf/min
- 3: acf/s
- 4: acf/D
- 5: Macf/D

#01 FILE 01

<i>Display</i>	<i>Explanation</i>	<i>Input Operation</i>
<pre> INPUT  INPUT END. PUSH [SHFT] &amp; [FLOW] PLEASE SET GAIN  # 0 1   F I L E   0 1 </pre>	<p>(21) Input is complete.</p> <p>The AGA function will start when [SHFT] &amp; [FLOW] keys are pressed. Press only the [FLOW] key to return to the flow mode without performing AGA.</p>	<p>Press [ENT] to return to the start of INPUT.</p> <p>Press [SHFT] &amp; [FLOW] to display the gain menu.</p>
<pre> INPUT  INIT ALL FILES SHOULD BE INITIALIZED. PUSH [ENT]  [ FLOW ] CANCEL # 0 1   F I L E   0 1 </pre>	<p>(22) Reset all pipe data files.</p> <p>You can reset all pipe data files (18 files) and system data (average times etc.) to initial value. Press [ENT] when you initialize all pipe data. Press [FLOW] to cancel the initialization of the data.</p>	<p>Press [ENT] to set.</p> <p>Press [FLOW] to cancel.</p>
<pre> INPUT  INIT ALL FILES WERE INITIALIZED.  PLEASE SHUT POWER &amp; REBOOT  # 0 1   F I L E   0 1 </pre>	<p>(23) All files were initialized.</p> <p>Please shut power, and reboot.</p> <p>Press [ON] after you push [SHFT] to power off.</p>	<p>Press [ON] after you push [SHFT] to power off.</p>

<b>Note:</b>
<ul style="list-style-type: none"> <li>Set data are checked as they are available value when exit from this mode. If some invalid data are found, the following message are appeared on the screen. " INPUT DATA FAULT. PLEASE RE-ENTER PIPE DATA." Check set data, and reset correct data again. If you shut power off in this invalid state, the self-diagnosis function detects " RAM CHECK ERROR" next startup.</li> <li>You can reset all pipe data files (32 files) and system data (average times etc.) to initial value. Refer to "<b>(5) of page 4-10</b>".or, Refer to "<b>(2) of page 4-14</b>"</li> </ul>

## INTEG Mode Operation

Settings for integration of measured flow data are performed in the INTEG mode. Press [INTG] while in the (FLOW) measurement mode.

<b>Note:</b>
<ul style="list-style-type: none"> <li>• During flow integration and integration standby, it is impossible to move the mode for changing the measurement condition. (Refer to Appendix G.) Stop integration and change measurement condition. (Current status is shown in “ status display area”. Refer to page 4-12.)</li> <li>• Flow integration does not work in Scanner Measurement.</li> </ul>

The various input items and displays are described below:

<b>Display</b>	<b>Explanation</b>	<b>Input Operation</b>
<p>[ when “METRIC” selected ]</p> <pre> INTEG INTEGRAL UNIT OF INTEGRAL 1: 100m3 2: 10m3 3: 1m3 4: 100L 5: 10L 6: 1L 7: 0.1L 8: 0.01L  # 01 FILE 01           </pre>	<p>(1) The first display of the INTEG mode.</p> <p>Select the measuring unit to be used on the integration display. (You will see a different display according to your unit system selection, “METRIC” or “USA”.)</p> <p>During integration, pressing [ENT] to select unit stops current integration and reset value to zero.</p>	<p>Press [?] to move the cursor up.</p> <p>Press [?] to move the cursor down.</p> <p>Press number keys to directly input a number.</p> <p>Press [ENT] to set.</p>
<p>[ when “USA” selected ]</p> <pre> INTEG INTEGRAL UNIT OF INTEGRAL 1: Mft3 2: ft3 3: Mgal 4: gal 5: Mbb1 6: bb1 7: Macf 8: acf  # 01 FILE 01           </pre>	<p>Proceed to step (2) after completing the selection.</p> <p><b>Note:</b></p> <p>1[ft<sup>3</sup>] = 0.0283168[m<sup>3</sup>]  1[gal] = 0.00378541[m<sup>3</sup>]  1[bb1] = 0.119240[m<sup>3</sup>]  1[acf] = 1233.482[m<sup>3</sup>]</p>	
<pre> INTEG START MODE 1: MANUAL 2: AUTO  # 01 FILE 01           </pre>	<p>(2) Select the integration start method.</p> <p>Selecting item 1 “MANUAL” allows the integration to start by pressing the [STRT] key.</p> <p>Selecting item 2 “AUTO” allows integration to start automatically at a preset time.</p> <p>Select 1, and then proceed to step (4), or  Select 2, and then proceed to step (3).</p>	<p>Press [?] to move the cursor up.</p> <p>Press [?] to move the cursor down.</p> <p>Press number keys to directly input a number.</p> <p>Press [ENT] to set.</p>

<i>Display</i>	<i>Explanation</i>	<i>Input Operation</i>
<pre> INTEG    START TIME SET 96 - 02 - 16           22 : 12 : 00  CURRENT TIME  96 - 02 - 16           22 : 12 : 40  # 0 1   FILE 0 1 </pre>	<p>(3) Input the integration start time.</p> <p>The time of initiation is displayed at upper side.</p> <p>Input the year, month, day, hour, minutes, and seconds. Specific items can be changed by moving the cursor to the desired item.</p> <p>The current time is displayed at lower side.</p> <p><b>Caution:</b> <i>Integration will not start if the time that one set sequence completes and returns to the flow mode is later than the set start time.</i></p> <p><i>Available time range is :</i>  <i>from 00:00:00, Jan. 1, 1995</i>  <i>(95-01-01 00:00:00)</i>  <i>to 23:59:59, Dec. 31, 2030</i>  <i>(30-12-31 23:59:59)</i></p>	<p>Press [?] to move the cursor right.</p> <p>Press [?] to move the cursor left.</p> <p>Press number keys to input a number.</p> <p>Press [ENT] to set.</p>
<pre> INTEG    STOP MODE   1 : MANUAL   2 : TIMER   3 : AUTO  # 0 1   FILE 0 1 </pre>	<p>(4) Designate the integration stop method.</p> <p>Select item 1 "MANUAL" to allow the integration to be stopped by pressing the [STOP] key.</p> <p>Select item 2 "TIMER" to allow integration to be stopped automatically after a preset period of time has elapsed.</p> <p>Select item 3 "AUTO" to allow integration to be stopped automatically at a preset time.</p> <p>Select 1, and return to the measurement mode.</p> <p>Proceed to step (7) when unreasonable input was done.</p> <p>Select 2, and then proceed to step (5), or</p> <p>Select 3, and then proceed to step (6).</p>	<p>Press [?] to move the cursor up.</p> <p>Press [?] to move the cursor down.</p> <p>Press number keys to directly input a number.</p> <p>Press [ENT] to set.</p>

<i>Display</i>	<i>Explanation</i>	<i>Input Operation</i>
<pre> INTEG    TIMER SET 06:00:00  #01  FILE 01 </pre>	<p>(5) Input the integration time span.</p> <p>The previously set time appears on the display. To change the time, input the hour, minutes, and then seconds.</p> <p>Specific items can be changed by moving the cursor to the desired item.</p> <p>After setting the time, return to the measurement mode.</p> <p>Proceed to step (7) when unreasonable input was done.</p>	<p>Press [?] ] to move the cursor right.</p> <p>Press [?] ] to move the cursor left.</p> <p>Press number keys to input number.</p> <p>Press [ENT] to set.</p>
<pre> INTEG    STOP TIME SET 96:02:17       13:00:00    START TIME 96:02:17       14:00:00  #01  FILE 01 </pre>	<p>(6) Input the integration finish time.</p> <p>The time which the display appeared is displayed at upper side.</p> <p>Input the year, month, day, hour, minute and then the second.</p> <p>It is also possible to move the cursor to a particular item for change.</p> <p>When start time is a manual, current time is displayed at lower side. When start time is automatic, start time is displayed at lower side.</p> <p>After setting the time, return to the measurement mode.</p> <p>Proceed to step (7) when unreasonable input was done.</p>	<p>Press [?] ] to move the cursor right.</p> <p>Press [?] ] to move the cursor left.</p> <p>Press number keys to input a number.</p> <p>Press [ENT] to set.</p>



## A-OUT Mode Operation

Settings for analog output are performed in the A-OUT mode.

Press [SHFT] then [AOUT] while in the (FLOW) measurement mode to enter the A-OUT mode.

The following explanation covers the various input items and displays:

<i>Display</i>	<i>Explanation</i>	<i>Input Operation</i>
<pre> A - OUT  A - OUT PATTERN  1 : 4 - 2 0  2 : 1 - 4 - 2 0  # 0 1   F I L E   0 1           </pre>	<p>(1) This is the first display of the A-OUT mode.</p> <p>Select the analog output pattern to be output.</p> <p>Select item 1 “4-20” to designate 4 mA output at 0 flow and 20 mA output at maximum flow set in step (2).</p> <p>Select item 2 “1-4-20” to include a 1 mA output for reverse (-) flow.</p>	<p>Press [?] to move the cursor up.</p> <p>Press [?] to move the cursor down.</p> <p>Press number keys to directly input a number.</p> <p>Press [ENT] to set.</p>
<pre> A - OUT  A - OUT SPAN  1 : 3 5 0 . 0 _                                m 3 / h  # 0 1   F I L E   0 1           </pre>	<p>(2) Input the maximum flow (span).</p> <p>The input value at this step is 100% (20 mA) for analog output.</p>	<p>Press [?] to move the cursor right.</p> <p>Press [?] to backspace.</p> <p>Press number keys to input a number.</p> <p>Press [CLR] to clear the display.</p> <p>Press [ENT] to set.</p>

<b>Display</b>	<b>Explanation</b>	<b>Input Operation</b>
<pre> A - OUT DAMPING 1: 1s 2: 3s 3: 10s 4: 30s 5: 100s  #01 FILE 01 </pre>	<p>(3) Select the analog damping time.</p>	<p>Press [?] to move the cursor up.</p> <p>Press [?] to move the cursor down.</p> <p>Press number keys to directly input a number.</p> <p>Press [ENT] to set.</p>
<pre> A - OUT A - OUT SETTING END PUSH [FLOW]  #01 FILE 01 </pre>	<p>(4) This step ends the A-OUT mode.</p> <p>Press [FLOW] to return to the measurement mode.</p>	<p>Press [FLOW] to return to the measurement mode.</p>

## CAL Mode Operation

Various calibrations are performed in the CAL mode. The following items are set in the CAL mode.

- 1) Correction method and coefficient value.
- 2) The zero/span correction for the measurement value.
- 3) Analog output value adjustment.

Press [SHFT], and then [CAL] while in the (FLOW) measurement mode to begin CAL mode.

The various input items and displays are described below:

<i>Display</i>	<i>Explanation</i>	<i>Input Operation</i>
<pre> CAL CALIBRATION  1: CORRECT WAY  2: ZERO - SPAN  3: 4 - 20 CAL  # 0 1   F I L E   0 1           </pre>	<p>(1) This is the first display of the CAL mode. Select the item to be set.</p> <p>Select item 1 to set the correction coefficient. Select item 2 to set the zero/span correction. Select item 3 to set the analog output reference value.</p> <p>Select 1, and then proceed to step (2),</p> <p>Select 2, and then proceed to step (8), or</p> <p>Select 3, and then proceed to step (13).</p>	<p>Press [?] to move the cursor up.</p> <p>Press [?] to move the cursor down.</p> <p>Press number keys to directly input a number.</p> <p>Press [ENT] to set.</p>
<pre> CAL VOLUME CORRECT  1: REYNOLDS  2: POINT CORRECT  3: OFF  # 0 1   F I L E   0 1           </pre>	<p>(2) Select the flow rate correction method.</p> <p>Select 1 "REYNOLDS" to perform correction by calculating the REYNOLDS number.</p> <p>Select 2 "POINT CORRECT" and input 8 flow velocity values, as well as the corresponding correction coefficient. Next, a straight line is drawn to correct the points.</p> <p>Select 3 "OFF" for no flow rate correction.</p> <p>Select 1, and then proceed to step (7),</p> <p>Select 2, and then proceed to step (3), or</p> <p>Select 3, and then proceed to step (7).</p>	<p>Press [?] to move the cursor up.</p> <p>Press [?] to move the cursor down.</p> <p>Press number keys to directly input a number.</p> <p>Press [ENT] to set.</p>

<b>Display</b>	<b>Explanation</b>	<b>Input Operation</b>
<pre> CAL DO YOU CHANGE?  1 : NO  2 : YES  # 0 1   F I L E   0 1 </pre>	<p>(3) Select whether or not to change the values of the "POINT CORRECT" correction.</p> <p>Select 1 "NO" to confirm the values without change.</p> <p>Select 2 "YES" to change the values.</p> <p>Select 1, and then proceed to step (6), or</p> <p>Select 2, and then proceed to step (4).</p>	<p>Press [?] to move the cursor up.</p> <p>Press [?] to move the cursor down.</p> <p>Press number keys to directly input a number.</p> <p>Press [ENT] to set.</p>
<pre> CAL VELOCITY 1 / 8  1 : 0 . 0 0           m / s  # 0 1   F I L E   0 1 </pre>	<p>(4) Input each value for the "POINT CORRECT" correction.</p> <p>Input the 8 flow velocity values. Input the values from 1 to 8, starting with the smallest value, up to the largest. The input value must be between 0.00 - 20.00 Press [ENT] after inputting each value. The display will change to the next value.</p> <p>Proceed to step (5) after all 8 values have been input.</p>	<p>Press [?] to move the cursor right.</p> <p>Press [?] to backspace.</p> <p>Press number keys to input a number.</p> <p>Press [CLR] to clear the display.</p> <p>Press [ENT] to set.</p>
<pre> CAL CORRECTS 1 / 8  1 : 1 . 0 0 0  # 0 1   F I L E   0 1 </pre>	<p>(5) Input the coefficient for each value of the "POINT CORRECT" correction.</p> <p>Input the coefficients for the 8 flow velocity values.</p> <p>The coefficient must fall between 0.500 - 2.000 Press [ENT] to set and change to the next input item.</p> <p>Proceed to step (6) after all 8 values have been input.</p>	<p>Press [?] to move the cursor right.</p> <p>Press [?] to backspace.</p> <p>Press number keys to input a number.</p> <p>Press [CLR] to clear the display.</p> <p>Press [ENT] to set.</p>

<i>Display</i>	<i>Explanation</i>	<i>Input Operation</i>
<pre> CAL  CORRECTS CHECK VELO. CORRECTS 1 / 8  0 . 0 0    1 . 0 0 0 2 / 8  0 . 2 0    1 . 0 0 0 3 / 8  0 . 4 0    1 . 0 0 0 4 / 8  0 . 6 0    1 . 0 0 0 5 / 8  0 . 8 0    1 . 0 0 0 6 / 8  1 . 0 0    1 . 0 0 0 7 / 8  1 . 2 0    1 . 0 0 0 8 / 8  1 . 4 0    1 . 0 0 0  # 0 1   F I L E   0 1 </pre>	<p>(6) Confirm the “ POINT CORRECT” correction input.</p> <p>Confirm the flow velocity and correction coefficient in the display.</p>	<p>Press [ENT] to set.</p>
<pre> CAL  VOLUME CORRECT END, PUSH [FLOW]  # 0 1   F I L E   0 1 </pre>	<p>(7) The correction coefficient input is complete.</p> <p>Press [FLOW] to return to the measurement mode.</p>	<p>Press [FLOW] to return to the measurement mode.</p>
<pre> CAL  ZERO SET 1 : NO CHANGE 2 : REWRITE 3 : CLEAR Z  # 0 1   F I L E   0 1 </pre>	<p>(8) This is the first display for zero/span input.</p> <p>The zero set is rewritten. The zero set replaces the offset value used to balance the flow rate. The flow value just before entering the CAL mode is set to the offset value that should be removed. <b>Therefore, enter the CAL mode and perform ZERO SET after the measurement value becomes stable.</b></p> <p>Select item 1 “ NO CHANGE” to keep the current value.</p> <p>Select item 2 “ REWRITE” to rewrite the offset value. (Z mark means the zero set value is 0.)</p> <p>Select item 3 “ CLEAR” to set the value to 0.</p> <p>After selecting, proceed to step (9).</p>	<p>Press [?] to move the cursor up.</p> <p>Press [?] to move the cursor down.</p> <p>Press number keys to directly input a number.</p> <p>Press [ENT] to set.</p>

<i>Display</i>	<i>Explanation</i>	<i>Input Operation</i>
<pre> CAL ZERO CORRECTION █ 1 : 0 . 0 0 %  # 0 1   F I L E   0 1 </pre>	<p>(9) Input the zero correction value. Zero correction sets the offset value at some percent of the maximum flow rate. Input the value here.</p> <p>The input range is -20.00 ? 20.00.</p>	<p>Press [?] to move the cursor right.</p> <p>Press [?] to backspace.</p> <p>Press number keys to input a number.</p> <p>Press [CLR] to clear the display.</p> <p>Press [ENT] to set.</p>
<pre> CAL SPAN CORRECTION █ 1 : 1 . 0 0 0  # 0 1   F I L E   0 1 </pre>	<p>(10) Input the span correction value. The span correction is the coefficient that is multiplied by the calculated flow rate. The flow rate is displayed as the value after the coefficient has been multiplied.</p> <p>The input range is 0.500 ? 2.000.</p>	<p>Press [?] to move the cursor right.</p> <p>Press [?] to backspace.</p> <p>Press number keys to input a number.</p> <p>Press [CLR] to clear the display.</p> <p>Press [ENT] to set.</p>
<pre> CAL ZERO CUT █ 1 : 0 . 0 0 %  # 0 1   F I L E   0 1 </pre>	<p>(11) Input the zero cut value. The zero cut is the boundary value to output 0 when the flow rate falls below a set level. The maximum flow rate is expressed as a percentage.</p> <p>The input range is 0.00 ? 10.00.</p>	<p>Press [?] to move the cursor right.</p> <p>Press [?] to backspace.</p> <p>Press number keys to input a number.</p> <p>Press [CLR] to clear the display.</p> <p>Press [ENT] to set.</p>

<b>Display</b>	<b>Explanation</b>	<b>Input Operation</b>
<div style="border: 1px solid black; padding: 10px;"> <p>CAL</p> <p>ZERO - SPAN END PUSH [FLOW]</p> <p>#01 FILE 01</p> </div>	<p>(12) This ends the zero/span mode.</p> <p>Press [FLOW] to return to the measurement mode.</p>	<p>Press [FLOW] to return to the measurement mode.</p>
<div style="border: 1px solid black; padding: 10px;"> <p>CAL</p> <p>4mA OUTPUT DOWN &lt; &gt; UP</p> <p>#01 FILE 01</p> </div>	<p>(13) This is the first display of 4-20 calibration.</p> <p>4mA output adjustment is performed.</p> <p>Measure the UFP-10 analog output and use the [?] [?] keys to adjust the output to 4mA. Then, press [ENT].</p>	<p>Press [?] to increase analog output.</p> <p>Press [?] to decrease analog output.</p> <p>Press [ENT] to set output.</p>
<div style="border: 1px solid black; padding: 10px;"> <p>CAL</p> <p>20mA OUTPUT DOWN &lt; &gt; UP</p> <p>#01 FILE 01</p> </div>	<p>(14) 20mA output adjustment is performed.</p> <p>Measure the UFP-10 analog output and use the [?] [?] keys to adjust the output to 20mA. Then, press [ENT].</p>	<p>Press [?] to increase analog output.</p> <p>Press [?] to decrease analog output.</p> <p>Press [ENT] to set output.</p>



## CHK Mode Operation

The set values for each item is displayed in list form in the CHK mode. The following items are checked in the CHK mode.

### Scanning

A-out,  
Correction Method,  
Zero Set,  
Zero/Span Correction,  
Zero Cut,  
AGC:

Appears in the 1st display of the CHK mode.

No Received Wave Processing,  
Moving Average Times,  
Refraction Angle Compensation,  
Integration Set:

Appears in the 2nd display of the CHK mode.

Print Set, Digital Output Set:

Appears in the 3rd display of the CHK mode.

Logging Set:

Appears in the 4th display of the CHK mode.

Press [SHFT] then [CHK] while in the (FLOW) measurement mode to enter the CAL mode. The various input items and displays are described below:

<i>Display</i>	<i>Explanation</i>	<i>Input Operation</i>
<pre> CHECK SCAN A - OUT PATTERN      4 - 2 0 SPAN         3 5 0 . 0               m 3 / h DAMPING      1 S CORRECT REYNOLDS ZERO SET ZERO COR . 0 . 0 0 % SPAN COR . 1 . 0 0 0 ZERO CUT 0 . 0 0 % AGC          NO  # 0 1   F I L E   0 1           </pre>	<p>(1) This is the first display of the CHK mode.</p> <p>Press [?] to display the next page.</p> <p>Press [FLOW] to return to the measurement mode.</p> <p>After advancing to the next page, proceed to step (2).</p>	<p>Press [?] to display the next page.</p> <p>Press [FLOW] to return to the measurement mode.</p>

<b>Display</b>	<b>Explanation</b>	<b>Input Operation</b>
<pre> CHECK R - OFF ACT          0% AVERAGE            2 5 6 ANGLE COR. STANDARD INTG  STRT  MANUAL INTG  STOP  MANUAL  # 0 1   FILE 0 1 </pre>	<p>(2) This is the second display of the CHK mode.</p> <p>Press [?] to display the next page.</p> <p>Press [?] to display the previous page.</p> <p>Press [FLOW] to return to the measurement mode.</p> <p>After returning to the previous page, proceed to step (1).</p> <p>After advancing to the next page, proceed to step (3).</p>	<p>Press [?] to display the previous page.</p> <p>Press [?] to display the next page.</p> <p>Press [FLOW] to return to the measurement mode.</p>
<pre> CHECK PRINT              NO 5 INT.              MANUAL STOP  SET      8 NO 9 6 0 0 TRANS    NO SEL.  Q +I - I V INT.    5 s STOP    MANUAL  SET      9 6 0 0 b p s ASYNC  8 NO  # 0 1   FILE 0 1 </pre>	<p>(3) This is the third display of the CHK mode.</p> <p>Press [?] to display the next page.</p> <p>Press [?] to display the previous page.</p> <p>Press [FLOW] to return to the measurement mode.</p> <p>After returning to the previous page, proceed to step (2).</p> <p>After advancing to the next page, proceed to step (4).</p>	<p>Press [?] to display the previous page.</p> <p>Press [FLOW] to return to the measurement mode.</p>
<pre> CHECK LOG          SET ON NAME  COMNT  INT. START  STOP  # 0 1   FILE 0 1 </pre>	<p>(4) This is the fourth display of the CHK mode.</p> <p>Press [?] to display the previous page.</p> <p>Press [FLOW] to return to the measurement mode.</p> <p>After returning to the previous page proceed to step (3).</p>	<p>Press [?] to display the previous page.</p> <p>Press [FLOW] to return to the measurement mode.</p>

## SYSTEM Mode Operation

Necessary settings for operating the UFP-10 are designated in the SYSTEM mode.  
The following items are set:

No Received Wave Processing, Moving Average Times, Refraction Angle Compensation, Internal Clock, AGC selection.

Press [SHFT], and then [SYS] while in the (FLOW) measurement mode to enter the SYSTEM mode.

The various input items and displays are described below:

Display	Explanation	Input Operation
<pre> SYSTEM SYSTEM SET NO RECEIVED WAVE 1: HOLD 2: 0% 3: 100%  #01 FILE 01           </pre>	<p>(1) This is the first display of the SYSTEM mode.</p> <p>Select the process for no received wave.</p> <p>Item 1 "HOLD" retains the value just prior to becoming a "No received wave".</p> <p>Item 2 "0%" sets the flow rate to zero.</p> <p>Item 3 "100%" sets the flow at the maximum rate.</p> <p>The values are saved until there is a received wave.</p>	<p>Press [↑] to move the cursor up.</p> <p>Press [↓] to move the cursor down.</p> <p>Press number keys to directly input a number.</p> <p>Press [ENT] to set.</p>
<pre> SYSTEM AVERAGE TIMES 1: 256 2: (16 - 512)  #01 FILE 01           </pre>	<p>(2) Set the moving average times.</p> <p>The moving average times calculates the average value over a set number of measurements. This average is calculated on an ongoing basis by including the most recent measurement value and dropping the oldest measurement value before calculation. The display value variance will decrease as the number of times increases. Select item 1 to set the number to 256. Select item 2 to set any other value. Use the number keys to input the value. The input range is 16 ? 512.</p>	<p>Press [↑] to move the cursor up.</p> <p>Press [↓] to move the cursor down.</p> <p>Press [→] to move the cursor right.</p> <p>Press [←] to backspace.</p> <p>Press number keys to input a number.</p> <p>Press [CLR] to clear the display.</p> <p>Press [ENT] to set.</p>

Display	Explanation	Input Operation
<pre> SYSTEM   ANGLE CORRECT   1: STANDARD   2: OFF  # 0 1 FILE 0 1 </pre>	<p>(3) Set the refraction angle compensation correction.</p> <p>Select item 1 "STANDARD" to perform refraction angle compensation correction during measurement.</p> <p>Select item 2 "OFF" to turn refraction angle compensation correction off during measurement.</p>	<p>Press [?] to move the cursor up.</p> <p>Press [?] to move the cursor down.</p> <p>Press number keys to directly input a number.</p> <p>Press [ENT] to set.</p>
<pre> SYSTEM   CLOCK SET   1: NO SET   2: SET  9 6 - 0 2 - 1 7           1 0 : 5 9 : 5 6  # 0 1 FILE 0 1 </pre>	<p>(4) Adjust the internal clock.</p> <p>Select 1 to pass setting.</p> <p>Select 2 to adjust the internal clock.</p> <p>Select 1, and then proceed to step (6).</p> <p>Select 2, and then proceed to step (5).</p>	<p>Press [?] to move the cursor up.</p> <p>Press [?] to move the cursor down.</p> <p>Press number keys to directly input a number.</p> <p>Press [ENT] to set.</p>
<pre> SYSTEM   CLOCK SET   9 6 - 0 2 - 1 7           1 1 : 0 0 : 0 0  # 0 1 FILE 0 1 </pre>	<p>(5) Adjust the internal clock.</p> <p>The internal clock time when the display opened appears.</p> <p>Use the number keys to input the year, month, day, hour, minutes, and seconds.</p> <p>After inputting the time, press [ENT]. The new time is set for the internal clock as soon as [ENT] is pressed.</p> <p><i>Available time range is :</i>  <i>from 00:00:00, Jan. 1, 1995</i>  <i>(95-01-01 00:00:00)</i>  <i>to 23:59:59, Dec. 31, 2030</i>  <i>(30-12-31 23:59:59)</i></p>	<p>Press [?] to move the cursor up.</p> <p>Press [?] to move the cursor down.</p> <p>Press number keys to directly input a number.</p> <p>Press [ENT] to set.</p>

Display	Explanation	Input Operation
<pre> SYSTEM  AGC SETTING  1: AGC OFF  2: AGC ON  # 0 1 FILE 0 1 </pre>	<p>(6) Set AGC.</p> <p>Select item 1 "AGC OFF" to turn the AGC function off.</p> <p>Select item 2 "AGC ON" to activate the AGC function during measurement.</p> <p>The AGC function is always off when the power is turned on. The receiver output fluctuates if there is a large change in the volume flow rate or surrounding temperature. The AGC function is effective in compensating for such fluctuations.</p>	<p>Press [?] to move the cursor up.</p> <p>Press [?] to move the cursor down.</p> <p>Press number keys to directly input a number.</p> <p>Press [ENT] to set.</p>
<pre> SYSTEM  UNIT SELECT  1: METRIC  2: USA  # 0 1 FILE 0 1 </pre>	<p>(7) Select a unit for measurement.</p> <p>Select 1 from two items when you adopt the metric system.</p> <p>Select 2 from two items when you adopt the USA system.</p>	<p>Press [?] to move the cursor up.</p> <p>Press [?] to move the cursor down.</p> <p>Or, you can directly press a number key instead of pressing [?] or [?].</p> <p>Press [ENT] to set.</p>
<pre> SYSTEM END PUSH [FLOW]  # 0 1 FILE 0 1 </pre>	<p>(8) This ends the System mode operation.</p> <p>Press [FLOW] to return to the measurement mode.</p>	<p>Press [FLOW] to return to the measurement mode.</p>

## LOG Mode Operation

The LOG mode is necessary for saving measurement data in the UFP-10 internal memory. The following three data items can be saved: Instantaneous Flow rate, forward integration, reverse integration. A maximum of 55,000 pieces of data can be saved and a maximum of 8 files can be saved. In this LOG mode, Logging time can be set, log files created, and deleted.

Press [SHFT], and then [LOG] while in the (FLOW) measurement mode to enter the LOG mode.

<b>Note:</b>
<ul style="list-style-type: none"> <li>During logging and logging standby, it is impossible to move the mode for changing the measurement condition. (Refer to Appendix G.) Stop logging and change measurement condition. (Current status is shown in "status display area". Refer to page 4-11.)</li> </ul>

The following explanation covers the various input items and displays:

<b>Display</b>	<b>Explanation</b>	<b>Input Operation</b>
<pre> LOG LOG SETTING LOGGING 1 : LOGGING 2 : DELETE  # 0 1 FILE 0 1           </pre>	<p>(1) This is the first display of the LOG mode.</p> <p>Select item 1 "LOGGING" to set LOG.</p> <p>Select item 2 "DELETE" to move to the log file delete display.</p> <p>Select 1, and then proceed to step (2). Select 2, and then proceed to step (13).</p> <p>During the execution of logging, the screen of the step (12) will be displayed.</p> <p>Proceed to step (12) during the execution of logging.</p>	<p>Press [?] to move the cursor up.</p> <p>Press [?] to move the cursor down.</p> <p>Press number keys to directly input a number.</p> <p>Press [ENT] to set.</p>
<pre> LOG LOGGING NAME 1 : 2 : 3 : 4 : 5 : 6 : 7 : 8 :  # 0 1 FILE 0 1           </pre>	<p>(2) Create a file number for a new log file.</p> <p>Select the file number of an unlabeled file from the 8 log file positions in the display. Do not select a number that already has a file or a blank area.</p>	<p>Press [?] to move the cursor up.</p> <p>Press [?] to move the cursor down.</p> <p>Press number keys to directly input a number.</p> <p>Press [ENT] to set.</p>

Display	Explanation	Input Operation
<pre> LOG LOG NAME  —  ! " # \$ % &amp; ' ( ) * + , - . / 0 1 2 3 4 5 6 7 8 9 : ; &lt; = &gt; ? @ A B C D E F G H I J K L M N O P Q R S T U V W X Y Z [ \ ] ^ _ ` a b c d e f g h i j k l m n o p q r s t u v w x y z {   } . 「 」 、 .  PRESS SHFT AND ENT TO FINISH </pre>	<p>(3) Input the log file name.</p> <p>Use the cursor to input a file name using the same procedure previously described for the pipe file name. A maximum of 8 characters may be input.</p> <p>Press [SHFT] and [ENT] when you finish input.</p> <p>A repeat can work with [?][?][?][?][?][?][CLR] keys.</p>	<p>Press [?] ] to move the cursor right.</p> <p>Press [?] ] to move the cursor left.</p> <p>Press [?] ] to move the cursor up.</p> <p>Press [?] ] to move the cursor down.</p> <p>Press [ENT] to set each character.</p> <p>Press [CLR] to erase character.</p> <p>Press [SHFT] and [ENT] when you finish input.</p>
<pre> LOG LOG COMMENT  —  ! " # \$ % &amp; ' ( ) * + , - . / 0 1 2 3 4 5 6 7 8 9 : ; &lt; = &gt; ? @ A B C D E F G H I J K L M N O P Q R S T U V W X Y Z [ \ ] ^ _ ` a b c d e f g h i j k l m n o p q r s t u v w x y z {   } . 「 」 、 .  PRESS SHFT AND ENT TO FINISH </pre>	<p>(4) Comments can be added to the newly created log file.</p> <p>Comments are input in the same manner as the file name in step (3). A maximum of 12 characters may be input.</p> <p>Press [SHFT] and [ENT] when you finish input.</p> <p>A repeat can work with [?][?][?][?][?][?][CLR] keys.</p>	<p>Press [?] ] to move the cursor right.</p> <p>Press [?] ] to move the cursor left.</p> <p>Press [?] ] to move the cursor up.</p> <p>Press [?] ] to move the cursor down.</p> <p>Press [ENT] to set each character.</p> <p>Press [CLR] to erase character.</p> <p>Press [SHFT] and [ENT] when you finish input.</p>
<pre> LOG LOG . INTERVAL 1 : 5 s 2 : 10 s 3 : 30 s 4 : 1 min 5 : 3 min 6 : 6 min 7 : 12 min </pre>	<p>(5) Select the interval for logging measured data.</p> <p>Instantaneous flow rate, + integration, and - integration is gathered simultaneously for the interval set in this step when logging starts.</p> <p>The file number and error codes are also gathered.</p>	<p>Press [?] ] to move the cursor up.</p> <p>Press [?] ] to move the cursor down.</p> <p>Press number keys to directly input a number.</p> <p>Press [ENT] to set.</p>

Display	Explanation	Input Operation
<pre> LOG  FREE MEMORY     25 hour     49 min     55 sec </pre>	<p>(6) The possible time of logging is indicated.</p> <p>Logging time can be set up within indicated time.</p> <p>In case that indicated time is short against required logging time, following operation should be done in previous step (Press [EXIT] to proceed to step (1) or (5) ).</p> <ol style="list-style-type: none"> <li>1) Delete existent log file.</li> <li>2) Select suitable "Log Interval" against required logging time.</li> </ol>	<p>Press [ENT] to set.</p> <p>Press [FLOW] to exit the log menu.</p> <p>Press [EXIT] to return to the previous display.</p>
<pre> LOG  START TIME SET . 96 - 02 - 17     14 : 00 : 00  CURRENT TIME 96 - 02 - 17     14 : 00 : 30 </pre>	<p>(7) Input the logging start time.</p> <p>The time of initiation is displayed at upper side.</p> <p>Input the year, month, day, hour, minutes, and seconds.</p> <p>Specific items can be changed by moving the cursor to the desired item.</p> <p>The current time is displayed at lower side.</p> <p><b>Note:</b> Logging will not operate correctly if the start time is set later than the stop time set in step (10).</p> <p>Available time range is :  from 00:00:00, Jan. 1, 1995  (95-01-01 00:00:00)  to 23:59:59, Dec. 31, 2030  (30-12-31 23:59:59)</p>	<p>Press [?] to move the cursor right.</p> <p>Press [?] to move the cursor left.</p> <p>Press number keys to input a number.</p> <p>Press [ENT] to set.</p>

Display	Explanation	Input Operation
<pre> LOG STOP MODE 1: TIMER STOP 2: AUTO STOP </pre>	<p>(8) Select the logging stop method.</p> <p>The lapse time from start to stop is set by item 1 "TIMER STOP".</p> <p>The stop time is set directly with item 2 "AUTO STOP".</p> <p>Select 1, and then proceed to step (9) or, Select 2, and then proceed to step (10).</p>	<p>Press [?] to move the cursor up.</p> <p>Press [?] to move the cursor down.</p> <p>Press number keys to directly input a number.</p> <p>Press [ENT] to set.</p>
<pre> LOG TIMER SETTING 01:50:00 </pre>	<p>(9) Input the logging time.</p> <p>The previously set time is displayed. Input the hour, minutes, and seconds. Specific items can be changed by moving the cursor to the desired item.</p> <p>After setting the time, return to the measurement mode.</p> <p>Proceed to step (11) when unreasonable input was done.</p>	<p>Press [?] to move the cursor right.</p> <p>Press [?] to move the cursor left.</p> <p>Press number keys to input a number.</p> <p>Press [ENT] to set.</p>
<pre> LOG STOP TIME SET . 96-02-08 10:00:00  START TIME SET 96-02-08 10:00:40 </pre>	<p>(10) Input the logging stop time.</p> <p>The initial time is displayed.</p> <p>Input the year, month, day, hour, minutes, and seconds.</p> <p>Specific items can be changed by moving the cursor to the desired item.</p> <p>Start time is displayed at lower side.</p> <p>After setting the time, return to the measurement mode.</p> <p>Proceed to step (11) when unreasonable input was done.</p>	<p>Press [?] to move the cursor right.</p> <p>Press [?] to move the cursor left.</p> <p>Press number keys to input a number.</p> <p>Press [ENT] to set.</p>

Display	Explanation	Input Operation
<pre> LOG  START TIME IS NOT AVAILABLE PUSH [EXIT]</pre>	<p>(11) It is an input error screen.</p> <p>Logging will automatically start at the set time. Logging will operate for the appropriate period and automatically stop at the log stop time.</p> <p>Confirm start time, current time, and stop time.</p> <p>Press [EXIT] to return to the previous display.</p>	<p>Press [EXIT] to return to the previous display.</p>
<pre> LOG  STOP LOGGING &amp; PUSH [ENT]  [ FLOW] CANCEL # 0 1 FILE 0 1</pre>	<p>(12) Stop Logging.</p> <p>This procedure stops the logging. All data logged up to that point is saved.</p> <p>Press [ENT] to return to the measurement mode.</p>	<p>Press [FLOW] to return to the measurement mode.</p>
<pre> LOG  DELETE LOGGING 1 : TEST FILE 2 : 3 : 4 : 5 : 6 : 7 : 8 :  # 0 1 FILE 0 1</pre>	<p>(13) Deleting log data.</p> <p>Select the log file to be deleted.</p> <p>Proceed to step (14) if the deletion was successful, or</p> <p>Proceed to step (15) if the deletion was not successful.</p>	<p>Press [FLOW] to return to the measurement mode.</p>

Display	Explanation	Input Operation
<pre> LOG   DELETED O.K.  # 0 1  F I L E  0 1 </pre>	<p>(14) This display will appear if the deletion was successful.</p> <p>Press [ENT] to return to the first log display.</p>	<p>Press [ENT] to return to the first log display.</p>
<pre> LOG   DELETED ERROR  # 0 1  F I L E  0 1 </pre>	<p>(15) This display will appear if the deletion was not successful.</p> <p>Re-select "DELETED" and correctly select the log file.</p> <p>Press [ENT] to return to the first log display.</p>	<p>Press [ENT] to return to the first log display.</p>

## DISPLAY Mode Operation

Measurement data display methods are set in the DISPLAY mode.  
Data may be displayed by one of the following methods:

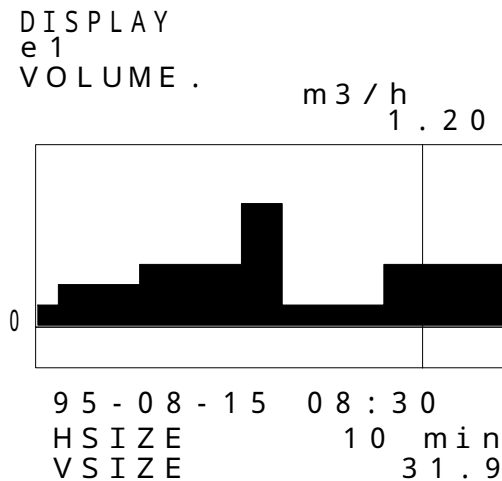
- Measurement Data Numerical Display (Default)
- Measurement Data Graph Display
- Log Data Numerical Display
- Log Data Graph Display

Press [SHFT], and then [DSP] while in the measurement mode (FLOW) to enter the DISPLAY mode.

The various input items and displays are described below:

Display	Explanation	Input Operation
<pre> DISPLAY  DISPLY METHOD  1 : NUMBERS  2 : GRAPHIC  3 : LOGGING DATA  # 0 1 FILE 0 1           </pre>	<p>(1) This is the first display of the DISP mode.</p> <p>Select item 1 "NUMBERS" for normal measurement data display.</p> <p>Select item 2 "GRAPHIC" for graph display of measurement data.</p> <p>Select item 3 "LOGGING DATA" to temporarily stop measurement data display and show log data.</p> <p>Select 1 to return to the measurement mode,</p> <p>Select 2, and then proceed to step (2) or,</p> <p>Select 3, and then proceed to step (3).</p>	<p>Press [?] to move the cursor up.</p> <p>Press [?] to move the cursor down.</p> <p>Press number keys to directly input a number.</p> <p>Press [ENT] to set.</p>
<pre> DISPLAY  TIME SCALE  1 : 10 min  2 : 20 min  3 : 1 h  4 : 2 h  5 : 6 h  6 : 12 h  7 : 24 h  # 0 1 FILE 0 1           </pre>	<p>(2) Select the time span for the graph display time axis.</p> <p>The time selected determines the size of the horizontal axis on the graph.</p> <p>The graph is displayed after selecting.</p>	<p>Press [FLOW] to return to the measurement mode.</p>

**Example:**



**Display Explanation:**

Flow Volume (Cursor):	The flow rate value at the cursor position.
Time Display:	The time at the cursor position.
Horizontal Axis:	The time set for the time axis span.
Vertical Axis:	The maximum flow rate (A-OUT SPAN) .

The graph continues to refresh over time during measurement from the right side of the display causing the graph to move left.

One display on the time axis span changes when refreshed.

The [?] [?] keys may be used to move the cursor on the display right or left to refer to past data. (Up to the end of the time span.) A repeat can work with [?] [?] with the key.

Press [FLOW] to return to normal numerical display.

Display	Explanation	Input Operation
<pre> DISPLAY  LOGGING NAME 1 : TEST FILE A 2 : TEST FILE B 3 : 4 : 5 : 6 : 7 : 8 :  # 0 1 FILE 0 1 </pre>	<p>(3) Select the log file to be displayed.</p> <p>Select a log file that is completed. Do not select files that are displayed as "-----" as these files have not yet been used.</p> <p>After selecting, proceed to step (4).</p>	<p>Press [↑] to move the cursor up.</p> <p>Press [↓] to move the cursor down.</p> <p>Press number keys to directly input a number.</p> <p>Press [ENT] to set.</p>
<pre> DISPLAY  LOGGING DISPLAY 1 : NUMBERS 2 : GRAPHIC  # 0 1 FILE 0 1 </pre>	<p>(4) Select the display method.</p> <p>Select item 1 "NUMBERS" for a numerical display of log data.</p> <p>Select item 2 "GRAPHIC" for a graph display of log data similar to the measurement data graph.</p> <p>Press [FLOW] to return to normal measurement.</p>	<p>Press [↑] to move the cursor up.</p> <p>Press [↓] to move the cursor down.</p> <p>Press number keys to directly input a number.</p> <p>Press [ENT] to set.</p>

When the display of log data, the [↑] [↓] keys may be used to find the data (called RECORD). And also, they may be used to move the cursor on the trend graph. The [←] [→] keys may be used to change the PAGE which is consist of the 120 RECORDs.

## PRINT Mode Operation

Measurement data, pipe data, and logging are printed using a special printer in the PRINT mode.

The following can be printed:

- Continuous Measurement Data Numerical Printout
- Continuous Measurement Data Graph Printout
- Pipe Data Printout
- Log Data Numerical Printout
- Log Data Graph Printout

Press [SHFT], and then [PRNT] while in the (FLOW) measurement mode to enter the PRINT mode.

The various input items and displays are described below:

Display	Explanation	Input Operation
<pre> PRINT PRINT SET PRINT 1 : DATA 2 : LOGGING DATA 3 : FILE  # 0 1 FILE 0 1           </pre>	<p>(1) This is the first display of the PRINT mode.</p> <p>Select 1 "DATA" to input measurement data print settings.</p> <p>Select 2 "LOGGING DATA" to input completed log data print settings.</p> <p>Select 3 "FILE" to input pipe file print settings.</p> <p>Select 1, and then proceed to step (2),            Select 2, and then proceed to step (7),            or,            Select 3, and then proceed to step (10)</p> <p>During the execution of printing, the screen of the step (12) will be displayed. Proceed to step (12) during the execution of printing.</p>	<p>Press [?] to move the cursor up.</p> <p>Press [?] to move the cursor down.</p> <p>Press number keys to directly input a number.</p> <p>Press [ENT] to set.</p>
<pre> PRINT PRINT DATA 1 : NUMBERS 2 : GRAPHIC  # 0 1 FILE 0 1           </pre>	<p>(2) Select the measurement data print type.</p> <p>Select item 1 "NUMBERS" to print numerical data.</p> <p>Select item 2 "GRAPHIC" to print graphical data.</p>	<p>Press [?] to move the cursor up.</p> <p>Press [?] to move the cursor down.</p> <p>Press number keys to directly input a number.</p> <p>Press [ENT] to set.</p>

Display	Explanation	Input Operation
<pre> PRINT PRINT INTERVAL 1: 5 s 2: 10 s 3: 30 s 4: 1min 5: 3min 6: 6min 7: 12min  # 0 1 FILE 0 1 </pre>	<p>(3) Select the measurement data print interval.</p> <p>Measurement data are printed at the selected interval.</p>	<p>Press [?] to move the cursor up.</p> <p>Press [?] to move the cursor down.</p> <p>Press number keys to directly input a number.</p> <p>Press [ENT] to set.</p>
<pre> PRINT STOP MODE 1: MANUAL STOP 2: TIMER STOP  # 0 1 FILE 0 1 </pre>	<p>(4) Select the print stop method.</p> <p>Select 1 "MANUAL" to continue printing until the user reenters the print mode and selects stop.</p> <p>Select 2 "TIMER" to end printing after a set period of time.</p> <p>Select 1, and then proceed to step (6) or,</p> <p>Select 2, and then proceed to step (5).</p>	<p>Press [?] to move the cursor up.</p> <p>Press [?] to move the cursor down.</p> <p>Press number keys to directly input a number.</p> <p>Press [ENT] to set.</p>
<pre> PRINT TIMER SETTING 0 0 : 5 0 : 0 0 _  # 0 1 FILE 0 1 </pre>	<p>(5) Input the timer set time for print stop.</p> <p>Input the hour, minutes, seconds for the period of time printing should continue before is stops. This is the timer set time.</p>	<p>Press [? ] to move the cursor right.</p> <p>Press [? ] to move the cursor left.</p> <p>Press number keys to input a number.</p> <p>Press [ENT] to set.</p>

Display	Explanation	Input Operation
<pre> PRINT  READY PRINTER &amp; PUSH [ENT]  # 0 1 FILE 0 1 </pre>	<p>(6) Print preparation confirmation display.</p> <p>Press [ENT] to start printing after confirming the UFP-10 and printer connection.</p> <p>The unit reverts to the measurement mode automatically once printing has started.</p> <p>Connect with printer correctly, before press [ENT] to execute printing. In case that [ENT] key was pressed without connecting with printer, UFP-10 will be not able to accept any input.</p>	Press [ENT] to start printing.

### Example of measurement data printout:

#### Numerical Printout

```

DATA
FILE          #01 . FILE 01
VOLUMETRIC   m3/h
INTEGRAL     0.01L
VELO.        m/s
START TIME   01-01-12 16:49:54
STOP TIME    01-01-12 16:52:54

```

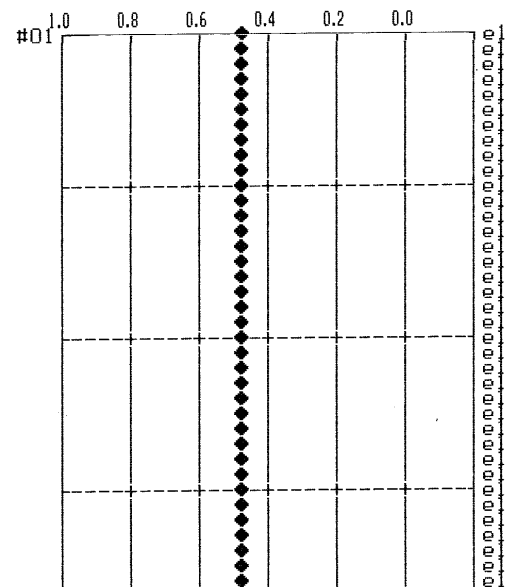
FILE ERR	hh:mm:ss	VOLUMETRIC	INTEGRAL+	INTEGRAL-	VELO.
#01	el 16:49:54	15.9	0	0	0.50
#01	el 16:49:59	15.9	0	0	0.50
#01	el 16:50:04	15.9	0	0	0.50
#01	el 16:50:09	15.9	0	0	0.50
#01	el 16:50:14	15.9	0	0	0.50
#01	el 16:50:19	15.9	0	0	0.50
#01	el 16:50:24	15.9	0	0	0.50
#01	el 16:50:29	15.9	0	0	0.50
#01	el 16:50:34	15.9	0	0	0.50
#01	el 16:50:39	15.9	0	0	0.50
#01	el 16:50:44	15.9	0	0	0.50
#01	el 16:50:49	15.9	0	0	0.50
#01	el 16:50:54	15.9	0	0	0.50
#01	el 16:50:59	15.9	0	0	0.50
#01	el 16:51:04	15.9	0	0	0.50
#01	el 16:51:09	15.9	0	0	0.50
#01	el 16:51:14	15.9	0	0	0.50
#01	el 16:51:19	15.9	0	0	0.50
#01	el 16:51:24	15.9	0	0	0.50
#01	el 16:51:29	15.9	0	0	0.50
#01	el 16:51:34	15.9	0	0	0.50
#01	el 16:51:39	15.9	0	0	0.50
#01	el 16:51:44	15.9	0	0	0.50
#01	el 16:51:49	15.9	0	0	0.50
#01	el 16:51:54	15.9	0	0	0.50
#01	el 16:51:59	15.9	0	0	0.50
#01	el 16:52:04	15.9	0	0	0.50
#01	el 16:52:09	15.9	0	0	0.50
#01	el 16:52:14	15.9	0	0	0.50
#01	el 16:52:19	15.9	0	0	0.50
#01	el 16:52:24	15.9	0	0	0.50
#01	el 16:52:29	15.9	0	0	0.50

#### Graphical Printout

```

DATA
FILE          #01 . FILE 01
A-OUT SPAN   31.9      m3/h
VELO. SPAN   1.00     m/s
HSIZE        50s/DIV
START TIME   01-01-12 16:53:22
STOP TIME    01-01-12 16:56:22

```



Display	Explanation	Input Operation
<pre> PRINT PRINT LOG DATA 1: NUMBERS 2: GRAPHIC  # 0 1 FILE 0 1 </pre>	<p>(7) Select the log data print type.</p> <p>Select item 1 "NUMBERS" to print numerical data.</p> <p>Select item 2 "GRAPHIC" to print graphical data.</p>	<p>Press [?] to move the cursor up.</p> <p>Press [?] to move the cursor down.</p> <p>Press number keys to directly input a number.</p> <p>Press [ENT] to set.</p>
<pre> PRINT 1: LOGFILE 1 2: LOGFILE 2 3: 4: 5: 6: 7: 8:  # 0 1 FILE 0 1 </pre>	<p>(8) Select a log file to be printed.</p> <p>A number and file name is displayed for complete log files. Select a complete log file.</p> <p>Do not select an incomplete file.</p>	<p>Press [?] to move the cursor up.</p> <p>Press [?] to move the cursor down.</p> <p>Press number keys to directly input a number.</p> <p>Press [ENT] to set.</p>
<pre> PRINT READY PRINTER &amp; PUSH [ENT]  # 0 1 FILE 0 1 </pre>	<p>(9) Print preparation confirmation display.</p> <p>Press [ENT] to start printing after confirming the UFP-10 and printer connection.</p> <p>The unit will revert to the measurement mode automatically once printing has started.</p> <p>Connect with printer correctly, before press [ENT] to execute printing. In case that [ENT] key was pressed without connecting with printer, UFP-10 will be not able to accept any key input.</p>	<p>Press [ENT] to start printing.</p>

Display	Explanation	Input Operation
<pre> PRINT  FILES 1: FILE 01 2: FILE 02 3: FILE 03 4: FILE 04 5: FILE 05 6: FILE 06 7: FILE 07 8: FILE 08  # 0 1 FILE 0 1 </pre>	<p>(10) Select a pipe file to printout.</p> <p>The pipe file name and number are displayed. Select a file.</p>	<p>Press [?] to move the cursor up.</p> <p>Press [?] to move the cursor down.</p> <p>Press number keys to directly input a number.</p> <p>Press [ENT] to set.</p>
<pre> PRINT  READY PRINTER &amp; PUSH [ENT]  # 0 1 FILE 0 1 </pre>	<p>(11) Print preparation confirmation display.</p> <p>Press [ENT] to start printing after confirming the UFP-10 and printer connection.</p> <p>The unit will revert to the measurement mode automatically once printing has started.</p>	<p>Press [ENT] to start printing.</p>
<pre> PRINT  STOP PRINT &amp; PUSH [ENT]  [ FLOW ] CANCEL # 0 1 FILE 0 1 </pre>	<p>(12) This display indicates that printing has stopped.</p> <p>Push [ENT] to stop printing.</p> <p>Push [FLOW] when you cancel this screen.</p> <p>In either case that [ENT] key or [FLOW] key was pressed, the unit will revert to the measurement mode automatically.</p> <p>Connect with printer correctly, before press [ENT] to execute printing. In case that [ENT] key was pressed without connecting with printer, UFP-10 will be not able to accept any key input.</p>	<p>Press [ENT] to return to the measurement mode.</p>

# Example of log data printout:

## Numerical Printout

```

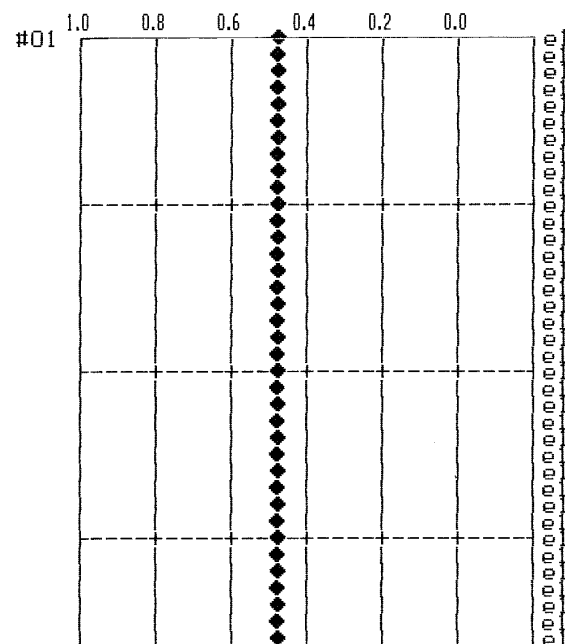
LOG
1.TEST
FILE          #01 . FILE 01
VOLUMETRIC    m3/h
INTEGRAL      0.01L
VELO.         m/s
START         01-01-12 17:24:00
STOP         01-01-12 17:27:00
    
```

FILE ERR	hh:mm:ss	VOLUMETRIC	INTEGRAL+	INTEGRAL-	VELO.
#01	el 17:24:00	15.9	0	0	0.50
#01	el 17:24:05	15.9	0	0	0.50
#01	el 17:24:10	15.9	0	0	0.50
#01	el 17:24:15	15.9	0	0	0.50
#01	el 17:24:20	15.9	0	0	0.50
#01	el 17:24:25	15.9	0	0	0.50
#01	el 17:24:30	15.9	0	0	0.50
#01	el 17:24:35	15.9	0	0	0.50
#01	el 17:24:40	15.9	0	0	0.50
#01	el 17:24:45	15.9	0	0	0.50
#01	el 17:24:50	15.9	0	0	0.50
#01	el 17:24:55	15.9	0	0	0.50
#01	el 17:25:00	15.9	0	0	0.50
#01	el 17:25:05	15.9	0	0	0.50
#01	el 17:25:10	15.9	0	0	0.50
#01	el 17:25:15	15.9	0	0	0.50
#01	el 17:25:20	15.9	0	0	0.50
#01	el 17:25:25	15.9	0	0	0.50
#01	el 17:25:30	15.9	0	0	0.50
#01	el 17:25:35	15.9	0	0	0.50
#01	el 17:25:40	15.9	0	0	0.50
#01	el 17:25:45	15.9	0	0	0.50
#01	el 17:25:50	15.9	0	0	0.50
#01	el 17:25:55	15.9	0	0	0.50
#01	el 17:26:00	15.9	0	0	0.50
#01	el 17:26:05	15.9	0	0	0.50
#01	el 17:26:10	15.9	0	0	0.50
#01	el 17:26:15	15.9	0	0	0.50
#01	el 17:26:20	15.9	0	0	0.50
#01	el 17:26:25	15.9	0	0	0.50
#01	el 17:26:30	15.9	0	0	0.50
#01	el 17:26:35	15.9	0	0	0.50
#01	el 17:26:40	15.9	0	0	0.50
#01	el 17:26:45	15.9	0	0	0.50
#01	el 17:26:50	15.9	0	0	0.50
#01	el 17:26:55	15.9	0	0	0.50
#01	el 17:27:00	15.9	0	0	0.50

## Graphical Printout

```

LOG
1.TEST
FILE          #01 . FILE 01
A-OUT SPAN    31.9      m3/h
VELO. SPAN    1.00     m/s
HSIZE         50s/DIV
START         01-01-12 17:24:00
STOP         01-01-12 17:27:00
    
```



## Example of pipe data printout:

FILE	MEASURE
#1.SAMPLE	
TIME	,96-08-14 21:04:50
INPUT	
TYPE OF PIPE	,1:NORMAL PIPE
OUTER DIAMETER	,114.0 mm
CIRCUMFERENCE	,358.1 mm
PIPE MATERIALS	,1:STEEL
PIPE THICKNESS	,3.9 mm
LINING MATERIALS	,1:NON
LINING THICKNESS	,0.0 mm
FLUID	,1:WATER
VISCOSITY	,1:STANDARD
KIND OF SENSOR	,1:STANDARD
SENSOR INSTALL.	,2:V METHOD
SENSOR DISTANCE	,103.8 mm CHECK
MEASURING UNIT	,1:m3/h
SYSTEM	
NO RECEIVED WAVE	,2: 0%
AVERAGE TIMES	,256
ANGLE CORRECT	,1:STANDARD
INTEG	
UNIT OF INTEGRAL	,8:0.01 L
START MODE	,1:MANUAL
STOP MODE	,1:MANUAL
A-OUT	
A-OUT PATTERN	,1:4-20
A-OUT SPAN	,31.9 m3/h
DAMPING	,1: 1s
CAL/CORRECTIONS	
VOLUME CORRECT	,1:REYNOLDS
CAL/ZERO SPAN	
ZERO SET	,NO SETTING
ZERO CORRECTION	,0.000 %
SPAN CORRECTION	,1.000
ZERO CUT	,0.000 %
TRANS	
SYNCHRONOUS	,ASYNCHRONOUS FIX
DATA BITS	,8 FIX
STOP BITS	,2 FIX
PARITY	,NON FIX
BAUD RATE	,1:9600bps
PRINTER PARAMETERS	
DATA BITS	,8 FIX
PARITY	,NON FIX
BAUD RATE	,9600 FIX

## TRANS Mode Operation

Data is transmitted from the UFP-10 unit to a personal computer using the TRANS mode.

The following can be transferred:

- Measurement Data (Numbers Only)
- Pipe Data
- Log Data (Numbers Only)

<b>Note:</b>
<p>⚠ Data reception software (PC Interface software for IBM compatible machine) and cable (sold separately) are required to transfer data to a computer. Furthermore, if data are transferred without a proper connection between the UFP-10 and computer, problems can develop with measurement and other operations. Refer to the manual supplied with the Interface Software for data reception methods and port settings.</p> <p>⚠ TRANS mode and PRINT mode do not work at the same time.</p>

Press [SHFT], and then [TRNS] while in the measurement mode (FLOW) to enter the TRANS mode.

The various input items and displays are described below:

Display	Explanation	Input Operation
<pre> TRANS TRANSMIT TRANSMITTING 1: DATA 2: LOGGING DATA 3: FILE 4: BAUD RATE  # 0 1 FILE 0 1           </pre>	<p>(1) This is the first display of the TRANS mode.</p> <p>Select item 1 "DATA" to input measurement data transfer settings.</p> <p>Select item 2 "LOGGING DATA" to input completed logging data transfer settings.</p> <p>Select item 3 "FILE" to input pipe data transfer settings.</p> <p>Select item 4 "BAUD RATE" to input transfer speed settings.</p> <p>Select 1, and then proceed to step (2),</p> <p>Select 2, and then proceed to step (10),</p> <p>Select 3, and then proceed to step (11),</p> <p>Select 4, and then proceed to step (14).</p> <p>During the execution of transmitting, the screen of the step (13) will be displayed.</p> <p>Proceed to step (13) during the execution of transmitting.</p>	<p>Press [↑] to move the cursor up.</p> <p>Press [↓] to move the cursor down.</p> <p>Press number keys to directly input a number.</p> <p>Press [ENT] to set.</p>

Display	Explanation	Input Operation
<pre> TRANS VOLUMETRIC  1: YES  2: NO  # 0 1 FILE 0 1 </pre>	<p>(2) Select whether to transfer volumetric flow rate data.</p> <p>Select item 1 to transfer. Select item 2 not to transfer.</p>	<p>Press [?] to move the cursor up.</p> <p>Press [?] to move the cursor down.</p> <p>Press number keys to directly input a number.</p> <p>Press [ENT] to set.</p>
<pre> TRANS + INTEGRAL  1: YES  2: NO  # 0 1 FILE 0 1 </pre>	<p>(3) Select whether to transfer + integration data.</p> <p>Select item 1 to transfer. Select item 2 not to transfer.</p>	<p>Press [?] to move the cursor up.</p> <p>Press [?] to move the cursor down.</p> <p>Press number keys to directly input a number.</p> <p>Press [ENT] to set.</p>
<pre> TRANS - INTEGRAL  1: YES  2: NO  # 0 1 FILE 0 1 </pre>	<p>(4) Select whether to transfer - integration data.</p> <p>Select item 1 to transfer. Select item 2 not to transfer.</p>	<p>Press [?] to move the cursor up.</p> <p>Press [?] to move the cursor down.</p> <p>Press number keys to directly input a number.</p> <p>Press [ENT] to set.</p>

Display	Explanation	Input Operation
<pre> TRANS   VELO .   1 : YES   2 : NO  # 0 1  F I L E   0 1 </pre>	<p>(5) Select whether to transfer velocity data.</p> <p>Select item 1 to transfer. Select item 2 not to transfer.</p>	<p>Press [?] to move the cursor up.</p> <p>Press [?] to move the cursor down.</p> <p>Press number keys to directly input a number.</p> <p>Press [ENT] to set.</p>
<pre> TRANS   TRANS . INTERVAL   1 : 5      s   2 : 10     s   3 : 30     s   4 : 1min   5 : 3min   6 : 6min   7 : 12min  # 0 1  F I L E   0 1 </pre>	<p>(6) Select the data transfer interval.</p> <p>Data are transferred at the selected interval.</p>	<p>Press [?] to move the cursor up.</p> <p>Press [?] to move the cursor down.</p> <p>Press number keys to directly input a number.</p> <p>Press [ENT] to set.</p>
<pre> TRANS   STOP MODE   1 : MANUAL STOP   2 : TIMER STOP  # 0 1  F I L E   0 1 </pre>	<p>(7) Select the transfer stop method.</p> <p>Selecting item 1 "MANUAL STOP" allows transmission to stop by re-entering the transfer mode and selecting STOP.</p> <p>Selecting item 2 "TIMER STOP" allows integration to stop automatically after a preset period of time has elapsed.</p> <p>Select 1, and then proceed to step (9), or Select 2, and then proceed to step (8).</p>	<p>Press [?] to move the cursor up.</p> <p>Press [?] to move the cursor down.</p> <p>Press number keys to directly input a number.</p> <p>Press [ENT] to set.</p>

Display	Explanation	Input Operation
<pre> TRANS TIMER SETTING 00:00:00  # 0 1 FILE 0 1 </pre>	<p>(8) Input the set time for transmission stop.</p> <p>Input the hour, minutes, and seconds for the time period that transmission should continue until stopping.</p>	<p>Press [?] to move the cursor right.</p> <p>Press [?] to move the cursor left.</p> <p>Press number keys to input a number.</p> <p>Press [ENT] to set.</p>
<pre> TRANS READY PC&amp;CABLE PUSH [ENT]  # 0 1 FILE 0 1 </pre>	<p>(9) Data transfer preparation confirmation display.</p> <p>Press [ENT] to begin data transfer after confirming the UFP-10 and computer connection. (Refer to the user's manual included with the communication software (sold separately) for connection method.)</p> <p>The unit will revert to the measurement mode automatically once data transfer has started.</p>	<p>Press [ENT] to begin data transfer.</p>
<pre> TRANS LOG FILES 1: LOGFILE 1 2: LOGFILE 2 3: 4: 5: 6: 7: 8:  # 0 1 FILE 0 1 </pre>	<p>(10) Select the log file to transfer.</p> <p>Select a log file that is completed. Do not select files that are displayed as "-----" as these files have not yet been used.</p> <p>After selecting, proceed to step (12).</p>	<p>Press [?] to move the cursor up.</p> <p>Press [?] to move the cursor down.</p> <p>Press number keys to directly input a number.</p> <p>Press [ENT] to set.</p>

Display	Explanation	Input Operation
<pre> TRANS  LOG FILES 1: FILE01 2: FILE02 3: FILE03 4: FILE04 5: FILE05 6: FILE06 7: FILE07 8: FILE08  # 01 FILE 01 </pre>	<p>(11) Select a pipe file to be transferred.</p> <p>The pipe file name and number are displayed. Select a file.</p>	<p>Press [?] to move the cursor up.</p> <p>Press [?] to move the cursor down.</p> <p>Press number keys to directly input a number.</p> <p>Press [ENT] to set.</p>
<pre> TRANS  READY PC&amp;CABLE PUSH [ENT]  # 01 FILE 01 </pre>	<p>(12) Data transfer preparation confirmation display.</p> <p>Press [ENT] to begin data transfer after confirming the UFP-10 and computer connection. (Refer to the user's manual included with the communication software (sold separately) for connection methods.)</p> <p>The unit will revert to the measurement mode automatically once data transfer has started.</p>	<p>Press [ENT] to begin (data transfer) (print).</p>
<pre> TRANS  STOP TRANS &amp; PUSH [ENT]  # 01 FILE 01 </pre>	<p>(13) This display indicates that transmission has stopped.</p> <p>Press [ENT] to stop printing.</p> <p>Press [FLOW] when you cancel this screen.</p> <p>In either case that [ENT] key or [FLOW] key was pressed, the unit will revert to the measurement mode automatically.</p>	<p>Press [ENT] to return to the measurement mode.</p>

Display	Explanation	Input Operation
<pre> TRANS  BAUD RATE 1: 9600 bps 2: 4800 bps 3: 2400 bps 4: 1200 bps  # 0 1 FILE 0 1 </pre>	<p>(14) Select the transmission speed.</p> <p>Select the baud rate to be used for data transmission.</p> <p>After setting, return to step (1).</p>	<p>Press [?] to move the cursor up.</p> <p>Press [?] to move the cursor down.</p> <p>Press number keys to directly input a number.</p> <p>Press [ENT] to set.</p>

## OPT (Option) Mode Operation

The OPT mode includes functions other than the flow meter such as the thickness meter, sound velocity meter, and pipe display.

1) Thickness Meter Function

Measures the thickness of pipe walls using a special probe. In order to use this function it is necessary to calibrate the unit using the test piece (included).

2) Sound Velocity Meter Function

Fluid can be placed in the cavity of the thickness meter test piece to measure sound velocity.

3) Pipe Display

Data (nominal diameter, outer diameter, thickness) for normally used pipes has been saved in the unit. It is possible to refer to this data.

Press [SHFT], and then [OPT] while in the (FLOW) measurement mode to enter the OPT mode.

The various input items and displays are described below:

Display	Explanation	Input Operation
<p>[when " METRIC" selected]</p> <pre> OPT   OPTION   1 : OPTION END   2 : THICK. / S . S   3 : PIPE DATA  # 0 1 FILE 0 1           </pre> <p>[when " USA" selected]</p> <pre> OPT   OPTION   1 : OPTION END   2 : THICK. / S . S  # 0 1 FILE 0 1           </pre>	<p>(1) This is the first display of the option mode.</p> <p>Select item 1 " OPTION END" to exit the option mode and return to the measurement mode.</p> <p>Select 2 " THICK. / S. S" to proceed to the thickness and sound velocity menu.</p> <p>Select 3 " PIPE DATA" to display pipe data.</p> <p>Select 2, and then proceed to step (2), or</p> <p>Select 3, and then proceed to step (8).</p>	<p>Press [?] to move the cursor up.</p> <p>Press [?] to move the cursor down.</p> <p>Press number keys to directly input a number.</p> <p>Press [ENT] to set.</p>

## [Option Mode End]

Be sure to exit the option mode by selecting item 1 "OPTION END". Do not exit the option mode by pressing the [FLOW] key.

Display	Explanation	Input Operation
<pre> OPT   THICK. /S.S   1: ADJUSTMENT   2: THICKNESS   3: SOUND SPEED  # 0 1 FILE 0 1           </pre>	<p>(2) This is the thickness and sound velocity menu.</p> <p>Select item 1 "ADJUSTMENT" to calibrate the thickness meter probe.</p> <p>Select item 2 "THICKNESS" to enter the thickness meter mode.</p> <p>Select item 3 "SOUND SPEED" to enter the sound velocity measurement mode.</p> <p>Be sure to calibrate before performing thickness or sound velocity measurements.</p> <p>Select 1, and then proceed to step (3),</p> <p>Select 2, and then proceed to step (6), or</p> <p>Select 3, and then proceed to step (7).</p>	<p>Press [?] to move the cursor up.</p> <p>Press [?] to move the cursor down.</p> <p>Press number keys to directly input a number.</p> <p>Press [ENT] to set.</p>
<pre> OPT   ADJUSTMENT   SET PROBE TO T.P   PUSH [ENT]  # 0 1 FILE 0 1           </pre>	<p>(3) This is the probe confirmation message.</p> <p>Confirm that the thickness probe is properly connected to the UFP-10 unit.</p> <p>Prepare the thickness meter test piece and couplant.</p> <p>After preparation, hold the probe against the test piece according to the calibration method below, and then press [ENT] to start calibration.</p>	<p>Press [ENT] to start calibration.</p>



Display	Explanation	Input Operation
<pre> OPT MATERIAL 1: STEEL 2: DUCTILE 3: CAST IRON 4: STAINLESS ST. 5: VINYL CHLORI. 6: FRP 7: ACRYLIC 8: PVDF 9:                               m / s  # 0 1 FILE 0 1 </pre>	<p>(6) Select the material for thickness measurement.</p> <p>The sound velocity of each material at the standard temperature is shown in appendix B.</p> <p>Select item 9 if measuring a different material or one of the listed materials at a different temperature.</p> <p>In this case, input the appropriate sound velocity.</p> <p><b>Note:</b> <i>Sound velocity of the material depends on temperature.</i></p> <p>After selecting material/sound velocity, measurement will start and the thickness is displayed.</p>	<p>Press [?] to move the cursor up.</p> <p>Press [?] to move the cursor down.</p> <p>Press number keys to directly input a number.</p> <p>Press number keys to input sound velocity.</p> <p>Press [CLR ] to clear the display.</p> <p>Press [ENT] to set.</p>

## [Thickness Measurement]

Be sure to calibrate before measuring thickness.

The time required for sound waves to propagate a thickness is measured and multiplied by the vertical wave velocity as shown below:

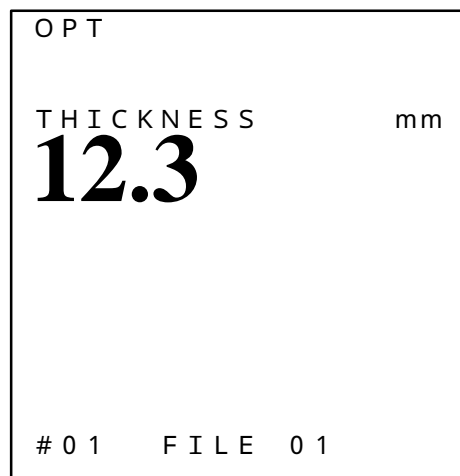
$$\text{Thickness} = \text{Sound Velocity (Vertical Wave)} \times \text{Round-trip Propagation Time} \div 2$$

Accordingly, if the input sound velocity (Vertical wave) is incorrect, the thickness measurement will not be correct, even if the propagation time is measured correctly.

The sound velocity varies according to the temperature, even with the same material. Therefore, it is important to input the sound velocity at the measurement temperature.

**Note:** Similarly, the test piece temperature must be 20°C during calibration. Calibrating at higher temperatures reduces the precision of the thickness measurement.

Refer to Section 3, "3-7 Sensor Installation, (4) Thickness Meter Probe" for probe handling.



**Thickness Measurement Display**

## [Thickness Display End]

Press [ENT] to end the thickness display and return to the option menu. Next, select item 1 "OPTION END" to return to the measurement mode.

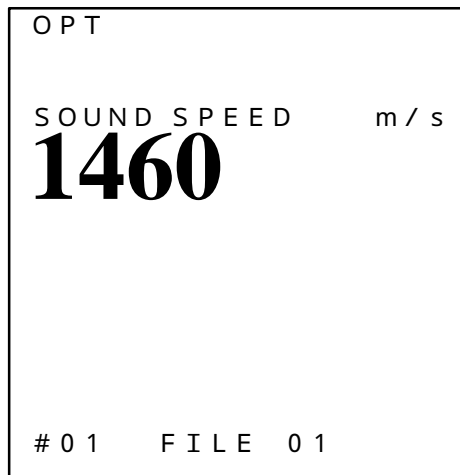
Display	Explanation	Input Operation
<div style="border: 1px solid black; padding: 10px; width: fit-content;"> <p>OPT</p> <p>SOUND ADJUSTMENT FAULT</p>            <p># 0 1   F I L E   0 1</p> </div>	<p>(7) This is the sound velocity confirmation display.</p> <p>Fill the sound velocity cell (the cavity in the thickness meter test piece) with the fluid to be measured. Apply the sensor firmly to the fluid, and then press [ENT].</p> <p>This starts the sound velocity measurement.</p> <p>Refer to the following sound velocity measurement for a full description.</p>	<p>Press [ENT] to start the sound velocity measurement.</p>

### [Sound Velocity Measurement]

Be sure to calibrate before measuring the sound velocity.

The sound velocity measurement function determines the vertical wave sound velocity of a fluid at the measurement temperature.

Refer to Section 3-7, " Sensor Installation, (4) Thickness Meter Probe" for probe handling.



**Sound Velocity Measurement Display**

### [Sound Velocity Display End]

Press [ENT] to exit the sound velocity display and return to the option menu. Then, select item 1 "OPTION END" to return to the measurement mode.

Display	Explanation	Input Operation
<pre> OPT  MATERIALS 1: STEEL 2: CAST IRON 3: VINYL CHLORI. 4: POLIETHYLENE 5: FRPM  # 0 1 FILE 0 1 </pre>	<p>(8) This is the first pipe data display.</p> <p>Select the pipe material to be displayed.</p> <p>Press [EXIT] to leave the pipe display and return to the thickness and sound velocity option menu.</p>	<p>Press [?] to move the cursor up.</p> <p>Press [?] to move the cursor down.</p> <p>Press number keys to directly input a number.</p> <p>Press [ENT] to set.</p> <p>Press [EXIT] to return to the option menu.</p>
<pre> OPT  NORMAL DIAMETER 1: 25 - 100 2: 125 - 300 3: 350 - 600 4: 650 - 1000 5: 1100 - 1800 6: 1900 - 2400 7: 2500 - 3000  # 0 1 FILE 0 1 </pre>	<p>(9) Select the pipe nominal diameter range to be displayed.</p> <p>Select the number of the range that includes the pipe nominal diameter to be displayed.</p>	<p>Press [?] to move the cursor up.</p> <p>Press [?] to move the cursor down.</p> <p>Press number keys to directly input a number.</p> <p>Press [ENT] to set.</p>
<pre> OPT  NORMAL OUTER 1: 25 34.0 2: 32 34.0 3: 40 48.6 4: 50 60.5 5: 65 76.3 6: 80 89.1 7: 90 101.6 7: 100 114.3  # 0 1 FILE 0 1 </pre>	<p>(10) Select the pipe nominal diameter to be displayed.</p> <p>Select the number of the pipe nominal diameter to be displayed.</p> <p>The outer diameter is shown to the right of the nominal diameter.</p>	<p>Press [?] to move the cursor up.</p> <p>Press [?] to move the cursor down.</p> <p>Press number keys to directly input a number.</p> <p>Press [ENT] to set.</p>

Display	Explanation	Input Operation
<pre> OPT   NORMAL  OUTER     25 . 0   34 . 0 SGP                3 . 2 SGPW               3 . 2 STPG - 40S        3 . 4 SUS - 5S          1 . 6 5 SUS - 10S         2 . 8 SUS - 20S         3 . 0 SUS - 40S         3 . 4  # 0 1  F I L E  0 1 </pre>	<p>(11) The pipe data that corresponds with the selected material and nominal diameter is displayed.</p> <p>The pipe name is shown to the left and thickness to the right.</p> <p>Press [ENT] to return to step (8). Press [EXIT] to leave the pipe display and return to the option menu.</p>	<p>Press [ENT] to return to the start of the pipe display.</p> <p>Press [ENT] [EXIT] to return to the option menu.</p>

## Gain Set Mode Operation

Auto Gain Adjustment is performed in this mode.

Press [SHFT], and then [FLOW] while in the FLOW mode to enter the GAIN mode.

The various input items and displays are described below:

Display	Explanation	Input Operation
<div style="border: 1px solid black; padding: 10px; width: fit-content;"> <pre> GAIN GAIN SETTING CHECK SENSORS PUSH [ENT]           </pre> </div>	<p>(1) This is the Auto Gain Adjustment mode display. After positioning the sensors on the pipe and completing other preparations, press [ENT] to start the Auto Gain Adjustment setting.</p> <p>To exit the Auto Gain Adjustment mode, press [FLOW] before starting the setting procedure.</p>	<p>Press [ENT] to start.</p> <p>Press [FLOW] before exiting the mode.</p>

"NOW SETTING" is displayed during the set procedure. A number is displayed just below this indication. The number starts at 1 and increases to 100 in increments of 1. The number increment indicates the gain setting is in operation. If the signal reception echo level is adequate, the setting should complete before the number reaches 100.

If the number reaches and stays at 100, the signal reception echo level was inadequate and the setting failed. The unit will enter the secondary gain set mode. After this mode is complete the display returns to the flow display and "AGA ERROR" will appear in the error display section.

<b>Note:</b>
The precision in the specifications is not guaranteed.

## LCD backlight ON/OFF

When the UFP-10 is used in dark circumstance, LCD backlight is useful.

Press [SHFT], and then [INTG] (B/L) while in the FLOW mode to turn the light on and off.

## LCD light and shade adjustment

Adjust the LCD light and shade by pressing [SHFT], and then [ ] or [ ] while in the FLOW mode.

## Section 5 Troubleshooting

---

If problems occur, carefully review this section. If a problem can not be solved by the steps shown in this section, contact a **Tokimec** representative or local dealer.

### **Display does not appear when the power is turned on.**

#### **Check**

- Is the battery or power supply connected properly?  
Open the battery cover at the back of the unit and confirm the connection.  
Confirm that the AC adaptor is plugged into the wall outlet and the connector is firmly plugged into the "POWER" connector on the unit.
- Is the battery fully charged?  
Refer to Section 3-6, "Battery Charge" and charge the battery.
- Was the [ON] key held down long enough?  
The [ON] key must be held down for a length of time before the power will come on.
- Doesn't the contrast of LCD fall down?  
Increase contrast.

### **The self-diagnosis display freezes and will not proceed to the next step.**

An error occurred during the hardware check. Record the display contents when the problem occurred and contact a Tokimec representative or local dealer. Press [SHFT], and then [ON] to turn off the power. If the keys do not respond, disconnect the battery or AC adaptor to turn the power off.

### **Can not input numbers.**

#### **Check**

- Is the desired number out of range?  
Check the mode explanation in section 4 that relates the operation being performed.

### **AGA Error.**

#### **Check**

- Is the pipe data being input correctly?  
Press[INPT] to confirm the input.
- Are the sensors attached correctly?  
Refer to Sections 3 and 4, and then confirm proper attachment.
- Is the sensor cable connected?  
Refer to Section 3, and then confirm proper connection.
- Is the pipe full of water?  
Confirm the condition of the pipe. Reattach the sensors to a full pipe and measure.

- Are the sensors attached to a defective (i.e., rusted) section of the pipe?  
Reattach the sensors using the Z method and measure.

If V method or another method that relies on reflection from the pipe wall is used, the ultrasonic wave will not adequately reflect, resulting in an inadequate signal reception echo.

- Are excess air bubbles in the pipe?  
Air bubbles can distort the ultrasonic wave resulting in inadequate signal reception echo.
- Are there sudden changes in the flow rate?  
Sudden changes in flow rate can cause the reception echo to become unstable, resulting in AGA gain decision errors.
- Other.  
The most likely problem is distortion in the ultrasonic wave due to an inadequate signal reception echo caused by something in the fluid.

<b>Note:</b>
Even if there is an AGA error, the secondary gain setting function will operate, allowing measurement. However, the measurement precision will be out of specifications.

## **AGC Error**

### Check

- Are there excess air bubbles in the pipe?  
Air bubbles can distort the ultrasonic wave, resulting in an inadequate signal reception echo.
- Are there sudden changes in the flow rate?  
Sudden changes in flow rate can cause the reception echo to become unstable, resulting in AGA gain decision errors.

## **Abnormal Value Error Output**

The flow is likely unstable due to air bubbles in the fluid, or the opening or closing of a valve upstream. This is not a defect.

## R-OFF Error

### Check

- Is pipe data input correct?  
Press [INPT], and then confirm the pipe data input.
- Are the sensors connected properly? (i.e., spacing, position, direction, couplant)  
Refer to Sections 3 and 4, and then confirm proper attachment.
- Is the sensor cable connected?  
Refer to Section 3, and then confirm proper connection.
- Was the gain set using AGA?  
Refer to Section 4, and then repeat AGA procedure.
- Is the pipe full of water?  
Confirm the condition of the pipe. Reattach the sensors to a full pipe and measure.
- Are the sensors attached to a defective (i.e., rusted) section of the pipe?  
Reattach the sensors using the Z method and measure.  
If V method or another method that relies on reflection from the pipe wall is used, the ultrasonic wave will not adequately reflect, resulting in an inadequate signal reception echo.
- Are there excess air bubbles in the pipe?  
Air bubbles can distort the ultrasonic wave, resulting in an inadequate signal reception echo.
- Other.  
The most likely problem is distortion in the ultrasonic wave due to an inadequate signal reception echo caused by something in the fluid.

### No error occurs with no fluid present.

The ultrasonic wave propagating the pipe wall produces an echo reception similar to the echo reception of a measured fluid, resulting in a erroneous no error condition. This situation can be caused by the pipe material, size or sensor attachment method. Reattach the sensors.

### Fluid was lost during measurement but no error occurred.

When the AGC is on, the amp output (electric signal) level can be maintained, even with deterioration due to air bubbles, automatically controlling the gain. However, in some cases when there is no longer any fluid flow nor an echo, the AGC may assume that the echo level has decreased, and increase the gain. This increased gain can be transmitted through the pipe walls, generating a quasi-echo which is mistaken for a normal echo. Measurement under these conditions is not accurate.

In this situation, turn off the AGC.

## **The flow rate changes but the measurement value does not change.**

### **Check**

- Is the flow rate unit appropriate?  
The flow unit is set at the end of the INPUT mode. Change the unit setting.
- Other.  
The ultrasonic wave produces an echo reception that is similar to the echo reception of measured fluid, resulting in a erroneous no error condition. This situation can be caused by the pipe material, size or sensor attachment method. In this condition, the echo will not change even if the flow rate changes, resulting in a continuous measurement value. Reattach the sensors.

## **Analog output is not within the 4 -20mA range.**

### **Check**

- Has the load exceeded the specifications?  
The maximum load resistance is 600  $\Omega$ . When several devices are connected in series, the total must not exceed 600  $\Omega$ . (Refer to Section 3.)
- Other  
Refer to Section 4, "CAL Mode" and confirm that the 4-20 mA adjustment is correct.

## **The battery will not charge.**

### **Check**

- Has the battery developed voltage memory?  
Refer to Section 3-6, "Battery Charging".
- Has the battery been stored for a long period of time without use?  
Refer to Section 3-6, "Battery Charging".
- Other  
There is a protection circuit in the unit to prevent battery charging if the surrounding temperature exceeds 40°C. If the protection circuit is operating, charging cannot occur, even if the surrounding temperature drops. Refer to Section 3-6, "Battery Charging."

## **Set data or log data lost when the power is turned off.**

The set data is saved in memory which is maintained by an internal backup Li battery. The backup battery can run-down after long periods of no use, resulting in the loss of data. Periodically, start the unit and check the battery level indicator. If the battery is low, contact your nearest Tokimec representative to replace the backup battery.

The lithium backup battery cannot be recharged.

The lithium backup battery provides power even when the unit is off.

The unit starts in the default mode (factory settings) if the unit is turned on without a functional backup battery.

## **No LCD Display**

Adjust the LCD light and shade using the [SHFT] and [? ] [? ] keys.

When the unit is used in places where the surrounding temperature is high, the light and shade is lowered to allow optimal viewing. If the battery runs out with the LCD in this setting, the LCD will still have shaded the next time it is turned on in normal temperature, making it difficult to view.

## **Can not receive key action**

Refer to appendix G.

## Section 6 Maintenance

---

### 6-1 Cleaning

Do not use thinner or similar chemicals to clean the unit. Wipe the unit with a soft cloth moistened with soap water. The LCD panel is made of acryl. Wiping it with chemical cleaners can result in the screen becoming white or deformed.

### 6-2 Battery Replacement

The battery performance will decrease over time, regardless of use. Be sure to follow all precautions listed in Section 3 "Battery Charging". Contact your Tokimec representative for a replacement battery when the old battery has reached the limit of its life span.



**Caution:**

The battery is specially designed for use with the UFP-10. Do not use any other battery. Failure to follow this caution may result in burns or injury.

### 6-3 Backup Battery Replacement

An internal backup battery is included with the UFP-10 to maintain a backup memory of time, set data, and log data. The life of the battery varies according to the frequency of unit use. In addition, there is drain on the backup battery even when the unit is turned off. The backup battery has a life of at least 5 years if the UFP-10 is not used at all. When the backup battery power is low, "Li" will appear on the display in the upper-left corner to the right of the error display area. When this display appears contact your Tokimec representative.

**Note:**

- If the unit is used without a functional backup battery, valuable data will be lost. In addition, the unit system data will be lost, preventing normal operation.
- Do not charge the backup battery.

## **Section 7 Term Designation**

---

### **[1-4-20 Output]**

One of the analog output forms available for the UFP-10. This form includes reverse-flow detection. Refer to "Analog Output."

### **[4-20 Output]**

One of the analog output forms available for the UFP-10. Refer to "Analog Output."

### **[Abnormal Value Removal]**

Measurement data that differ substantially from the previously collected data are automatically removed if the data are clearly in error.

### **[AGA]**

Automatic Gain Adjustment function. This function is performed after the sensors are attached and before measurements to set the optimum reception gain are performed.

### **[AGC]**

Automatic Gain Control function. The AGC function controls the gain automatically to maintain the reception echo at the level set with AGA when the reception echo becomes unstable. The AGC is reset to off each time the power is turned on. The AGC can be turned on or off in the SYSTEM mode.

## **[Analog Output]**

The analog output is the current output from the UFP-10 unit that corresponds with the measurement results. When the flow rate is 0, the output is 4mA (0%). When the flow rate is at a preset maximum flow rate (Qmax), the output is 20mA (100%). The current output between these two points is a straight interpolation (4 - 20 output). In addition, if 1-4-20 output is selected, there is a 1mA output during reverse flow. Analog output is also called A-OUT.

## **[A-OUT]**

Analog output. Refer to "Analog Output".

## **[A-OUT Span]**

Maximum flow rate (Qmax) set for the UFP-10 unit. The A-OUT span determines the scale for analog output and graph displays.

## **[A-OUT Pattern]**

There are 2 patterns, one for 4-20 which corresponds to forward flow only, and one for 1-4-20 which corresponds to forward and reverse flow. Refer to Section 2, "Specifications and Configuration, 2-3 Product Specifications."

## **[A-OUT Mode]**

Mode for setting analog output.

## **[Attachment Method]**

This is the method used to attach the sensors to the pipe. There are 5 different attachment methods: V, Z, N, W, and W + Z. The V method is recommended.

## **[CAL Mode]**

The correction coefficient, used to calculate the flow rate from the measured line flow speed, and the analog output calibration are performed in the CAL mode.

## **[CHK Mode]**

The various settings for the UFP-10 are confirmed in the CHK mode.

## **[Couplant]**

Couplant is a contact medium applied to the pipe and sensor to improve the acoustic contact. Use machine oil or silicon. Refer to Section 3, "Equipment."

## **[Damping]**

The response time for the analog output is set as "damping."

## **[Digital Output]**

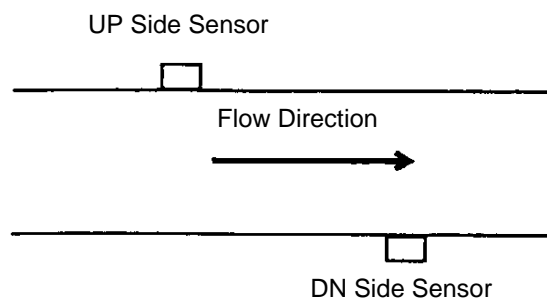
This is the measurement result or log data output to the serial port of a personal computer. A special cable and communication software are required for the computer. Also called TRANS.

## **[DISPLAY Mode]**

The DISPLAY mode is used to designate whether measurement data and logging data should be displayed as numerical values or as a trend graph.

## **[DN]**

DN indicates the downstream area of measurement. The sensor set downstream is called the DN side.



## **[Flow Rate]**

Flow rate is the volume of fluid that moves during a unit of time. It is correctly called "Volumetric Flow Rate." Printed, transferred, or logged at a set interval.

## **[Flow Velocity]**

Flow velocity is the pipe cross section average flow velocity calculated from the flow velocity of the measured line (sound pass) to which the pipe cross section area is multiplied.

## **[GAIN Set Mode]**

Automatic Gain Adjustment (AGA) is performed in the GAIN Set mode after the sensors have been attached, the pipe data has been set, and before measurement.

## **[INPUT Mode]**

The basic data required to perform flow measurements is input in the INPUT mode. Pipe data and sensor are selected in this mode.

## **[INTEG Mode]**

Conditions for measurement integration are set in the INTEG mode. Manual or Auto start and stop is also set in this mode.

### **[Integration Value]**

This is the sum of the instant flow rate added in series. The time for integration can be set. It is also possible to print, transmit, and log the integration at set intervals. Refer to Section 4, "Operation."

### **[Log File]**

The log file is a collection of measurement data saved in series. This file can be printed, transferred, or deleted in the log set.

### **[Logging]**

Logging saves measurement data (flow rate, integrated values) with the time and error information into the units of internal memory in succession for a set period of time at a set interval.

### **[LOG Mode]**

Conditions for logging (saving) measurement data are set in the LOG mode.

### **[Low Flow Cut]**

Refer to Zero Cut.

### **[Measurement Pipe]**

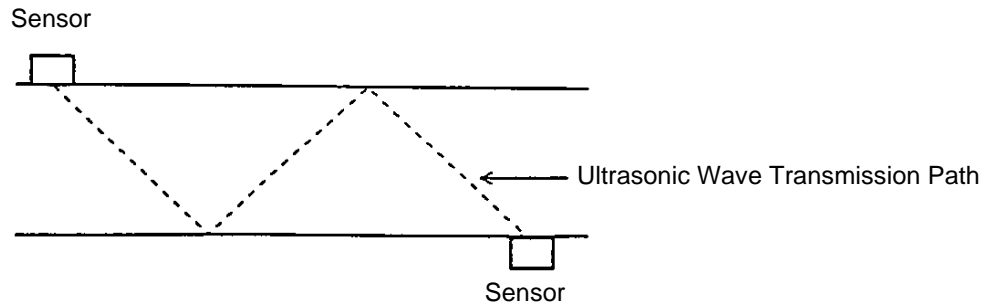
A measurement pipe is a short pipe/sensor combination that is inserted into the line to be measured.

### **[Mode]**

There are various modes for measurement, pipe data input and output settings. Refer to section 4.

## [N Method]

The sensor arrangement is the same refraction angle line as the Z method. The ultrasonic wave reflects twice in the pipe.



## [No Received Wave Processing]

Display and analog output processing when measurement is not possible due to a loss echo resulting from a drop in water level. Refer to Section 4, "Operation." This is also called R-OFF processing.

## [OPT Mode]

The OPT mode is used to display the pipe display or use the Thickness Meter or Sound Velocity Meter.

## [Other Sensors]

Sensors other than the standard and optional sensors. The physical parameters are input using the "Other Sensors" menu. Normally not used.

## [Pipe Display]

Pipe chart. This is a display of data for commonly used pipes. It includes pipe thickness, nominal diameter, and outer diameter.

## [Pipe File]

Pipe Data File. The pipe file contains data about the pipe and sensor to be used. The data can be printed or transferred as a file. Refer to Appendix A for the pipe data table.

## [PRINT Mode]

The conditions for data output to the printer are set in the PRINT mode.

## [Refraction Angle Correction]

Refer to Section 2, "Specifications and Configuration, 2-3 Product Specifications."

## [R-OFF]

This indicates that the reception echo is not being received in series. The loss of reception echo can be due to excessive bubbles in the fluid, pipe material that interferes with the ultrasonic wave, or substantial rust on the pipe. Refer to "No received wave processing."

## [Scanner]

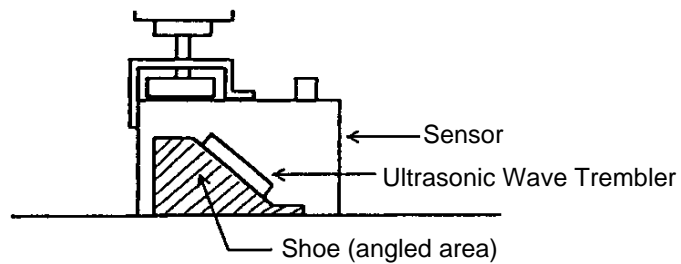
A device to allow a maximum of 8 sets of sensors to be used for measuring several pipes at the same time. Measurement switches between sensors at a set interval. Setting is made in the MULTI mode. Scanner can also be used for 2-PATH measurements.

## [Sensor]

The transducer used by the flow meter for measurement. This is called a probe with the thickness meter. The standard sensor (used for measuring flow) and the thickness probe (used for measuring thickness and sound velocity) are included with the UFP-10 as standard accessories.

## [Shoe]

The shoe is a wedge used to transmit and receive the ultrasonic wave at an angle.



## **[Span Correction]**

Span correction is the coefficient that is multiplied by the result of measurement for data display. The volume is set between 0.5 ? 2.0. Normally 1.0 may be set as this value.

*Example: If the span correction is set at 1.02, 5.1m<sup>3</sup>/H will appear instead of 5m<sup>3</sup>/H.*

## **[Status]**

A display of the UFP-10 operating condition. Shown in the upper-right area of the display during measurement. (Refer to Section 4, "Operation.")

## **[Straight Pipe Length]**

This is the length of the straight portion of a pipe. When a pipe length of 10D is required, the pipe length should be more than 10 x D (D = the inner diameter of the pipe.)

## **[SYSTEM Mode]**

No received wave processing, moving average times, compensation for angle of fraction, time, and AGC are set in the SYSTEM mode.

## **[Test Piece]**

Test piece is used to calibrate the thickness meter. The test piece also includes a sound velocity measurement cell for measuring sound velocity. The test piece is made of SUS 304. The thickness of the calibration test piece is 7mm and the sound velocity measurement cell is 20 mm deep.

## **[TRANS]**

Refer to digital output.

## **[TRANS Mode]**

Conditions for transferring data to a computer are set in the TRANS mode.

## **[Transmission Power]**

The transmission power is usually set to LOW. However, this power can be set to HIGH when there is interference to the echo (AGA or R-OFF error) from the pipe material, rust, or the measurement fluid. It can be set when the 1MHz sensors are selected.

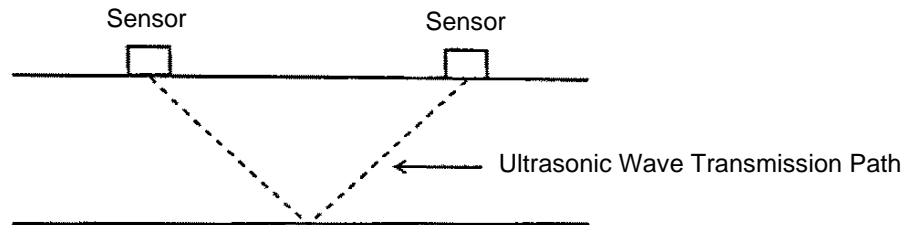
## **[UP]**

UP indicates the upstream area of measurement. The sensor set upstream is called the UP side. Refer to "DN."

### [V Method]

In the V method, 2 sensors are placed on the same side of the pipe and the ultrasonic wave reflects once on the bottom surface. Sensor attachment simpler with the Z method.

One characteristic of the V method is the ability to reduce the effect of measurement errors due to flow velocity distribution interference. This attachment method is recommended.

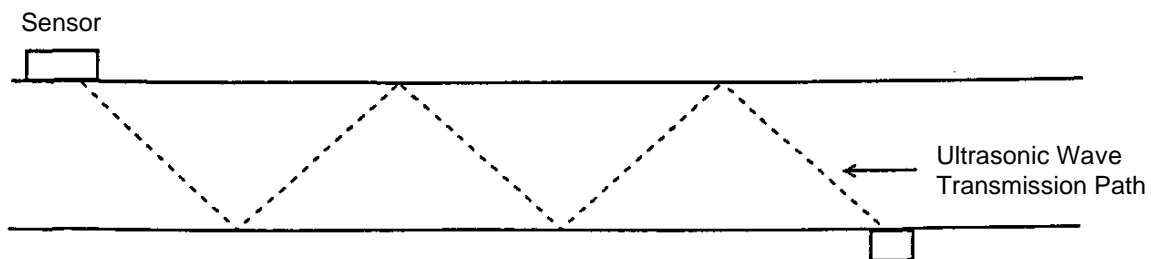


### [Volum.] [Volume]

This is an abbreviation of Volumetric Flow Rate. It is also written as Volume Flow Rate. Flow Rate and Flow are used in this manual.

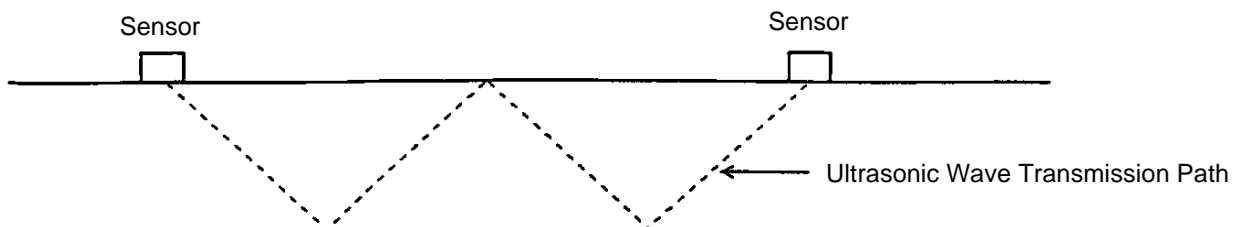
### [W + Z Method]

The sensor arrangement has the same refraction angle line as the Z method. The ultrasonic wave reflects 4 times in the pipe.



### [W Method]

The sensor arrangement has the same refraction angle line as the V method. The ultrasonic wave reflects 3 times in the pipe.



## [Zero Correction]

This is the offset value used to display the measurement results in an offset condition. Set the offset volume as a percent of the maximum flow rate ( $Q_{max}$ ). Normally 0 may be set as this value.

*Example: If the  $Q_{max}$  is  $10\text{m}^3/\text{H}$  and the zero correction is set at  $-5\%$ ,  $4.5\text{m}^3/\text{H}$  will appear instead of  $5\text{m}^3/\text{H}$ .*

## [Zero Cut]

This is a limiting value. All measurements below this set value are displayed as 0. This value is shown as a percent of the maximum flow rate ( $Q_{max}$ ). Normally 0 may be set as this value.

*Example: If the  $Q_{max}$  is  $10\text{m}^3/\text{H}$  and the zero cut is set at  $5\%$ , 0 will appear for all instantaneous flows below  $0.5\text{m}^3/\text{H}$ .*

## [Zero Set]

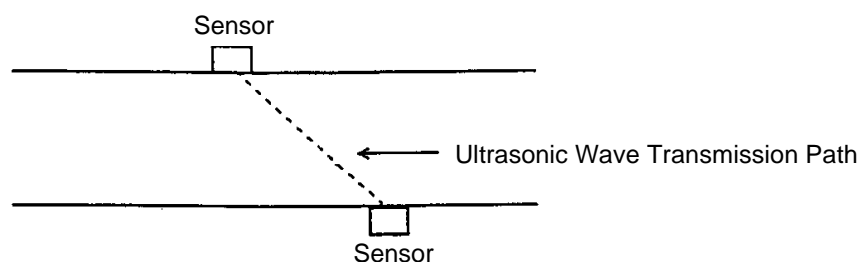
The zero set is the balancing value to maintain the display of results at a balance. The flow rate when the CAL mode is entered is used to set this value. During the zero set is set, "FLOW ZERO" message is appeared at the mode display area on the FLOW mode screen.

*Example: Though the measurement fluid doesn't flow, the measured flow rate may not be zero. (It may have a few offset value.) In this case, if the zero set is set, the offset value as the zero set will be removed on the screen.*

## [Z Method]

In the Z method, the sensors are placed on the top and bottom in a diagonal line and the wave passes through the center of the pipe.

The Z method is the next best method if measurement cannot be performed using the V method.



## Appendix A

### Pipe data saved in the UFP-10 memory

<b>INPUT</b>	
Pipe Type	Pipe, Measurement Pipe
Outer Diameter Dimension	[mm]
Pipe Material	Sound Velocity [m/s]
Pipe Thickness	[mm]
Lining Material	Sound Velocity [m/s]
Lining Thickness	[mm]
Measurement Fluid	Sound Velocity [m/s]
Kinematic Viscosity Coefficient	[cm <sup>2</sup> /s]
Sensor Type	Standard, Large, Small HI-Freq, Small LO-Freq, High Temperature, Other
Sensor Attachment	Z, V, N, W, W+Z
<b>SYSTEM</b>	
No Received Wave Processing	100%, 0, Hold
Moving Average Times	16 ? 512
Refraction Angle Compensation	Yes, No
<b>A-OUT</b>	
A-OUT Pattern	4-20, 1-4-20
A-OUT Span	[m <sup>3</sup> /h], [m <sup>3</sup> /min], [m <sup>3</sup> /s],[[m <sup>3</sup> /D], [ft <sup>3</sup> /h], [ft <sup>3</sup> /min], [ft <sup>3</sup> /s], [ft <sup>3</sup> /D], [Mft <sup>3</sup> /D], (1[ft <sup>3</sup> ] = 0.0283168[m <sup>3</sup> ]) [gal /h], [gal /min], [gal /s], [gal /D], [Mgal /D], (1[gal] = 0.00378541[m <sup>3</sup> ]) [bbl/h], [bbl /min], [bbl /s], [bbl /D], [Mbbl /D] (1[bbl] = 0.119240[m <sup>3</sup> ]) [acf/h], [acf /min], [acf /s], [acf /D], [Macf /D] (1[acf] = 1233.482[m <sup>3</sup> ])
Damping	[s]
<b>CAL/ Correction Coefficient</b>	
Flow Velocity Correction	Reynolds, Point Correction, Off
<b>CAL/Zero Span</b>	
Zero Set	Yes, No
Zero Correction	[%] -20.0 ? +20.0
Span Correction	0.5 ? 2.0
Zero Cut	[%] 0 ? 10.0

Other: Scanner Channel Count, Scanner Order

## Appendix B

### Sound velocity data used by UFP-10

#### Flow Rate Measurement

Pipe Material	Sound Velocity [m/s] (at 20°C)
Steel	3,200
Ductile Iron	3,000
Cast Iron	2,500
SUS (Stainless Steel)	3,100
PVC	2,280
FRP	2,560
Acryl	2,720

Lining Material	Sound Velocity [m/s]
Tar Epoxy	2,000
Mortar	2,500
Rubber	1,900

Measurement Fluid	Sound Velocity [m/s] (at 13°C)
Water	1,460
Sea Water	1,510

#### Thickness Measurement

Pipe Material	Sound Velocity [m/s] (at 20°C)
Steel	5,900
Ductile Iron	5,800
Cast Iron	4,500
SUS (Stainless Steel)	5,730
PVC	2,280
FRP	2,560
Acryl	2,720
PVDF	2,300

## Appendix C

Ultrasonic under water sound velocity chart

Water Temperature [°C]	Sound Velocity [m/s]	Water Temperature [°C]	Sound Velocity [m/s]	Water Temperature [°C]	Sound Velocity [m/s]
0	1402.74	34	1518.12	68	1554.70
1	1407.72	35	1520.12	69	1554.93
2	1412.58	36	1522.06	70	1555.12
3	1417.33	37	1523.93	71	1555.27
4	1421.97	38	1525.74	72	1555.38
5	1426.50	39	1527.49	73	1555.44
6	1430.93	40	1529.18	74	1555.47
7	1435.25	41	1530.81	75	1555.46
8	1439.46	42	1532.37	76	1555.40
9	1443.58	43	1533.88	77	1555.31
10	1447.60	44	1535.33	78	1555.19
11	1451.52	45	1536.73	79	1555.02
12	1455.34	46	1538.06	80	1554.82
13	1459.07	47	1539.35	81	1554.57
14	1462.71	48	1540.57	82	1554.30
15	1466.25	49	1541.75	83	1553.98
16	1469.71	50	1542.87	84	1553.63
17	1473.08	51	1543.94	85	1553.25
18	1476.36	52	1544.95	86	1552.83
19	1479.55	53	1545.92	87	1552.37
20	1482.66	54	1546.84	88	1551.88
21	1485.69	55	1547.70	89	1551.35
22	1488.64	56	1548.52	90	1550.79
23	1491.50	57	1549.29	91	1550.20
24	1494.29	58	1550.01	92	1549.58
25	1497.00	59	1550.68	93	1548.92
26	1499.64	60	1551.31	94	1548.23
27	1502.20	61	1551.89	95	1547.50
28	1504.69	62	1552.42	96	1546.75
29	1507.10	63	1552.91	97	1545.96
30	1509.44	64	1553.36	98	1545.14
31	1511.72	65	1553.76	99	1544.29
32	1513.92	66	1554.12	100	1543.41
33	1516.05	67	1554.43		

# Appendix D

## Pipe Chart

### Cast Iron

Name			Water Works Type Cast Iron		Straight Pipe		Ductile Cast Iron Pipe							
JIS Number			JIS G5521-1977		JIS G5522-1977		JIS G5526-1989							
Material			FC		FC									
Type			Normal	Low Pressure	Normal	Low Pressure	11	11.5	12	12.5	13	13.5	14	14.5
Nominal Diameter	Outer Diameter	Lining Thickness												
75	93	4	9		7.5		7.5				6			
100	118	4	9		7.5		7.5				6			
150	168	4	9.5	9	8	7.5	7.5				6			
200	220	4	10	9.4	8.8	8	7.5				6			
250	271.6	4	10.8	9.8	9.5	8.4	7.5				6			
300	322.8	6	11.4	10.2	10	9	7.5				6.5			
350	374	6	12	10.6	10.8	9.4	7.5				6.5			
400	425.6	6	12.8	11	11.5	10	8.5		7.5		7			
450	476.8	6	13.4	11.5	12	10.4	9		8		7.5			
500	528	6	14	12	12.8	11	9.5		8.5		8			
600	630.8	6	15.4	13	14.2	11.8	11		10		9		8.5	
700	733	8	16.5	13.8	15.5	12.8	12		11		10		9	
800	836	8	18	14.8	16.8	13.8	13.5		12		11		10	
900	939	8	19.5	15.5	18.2	14.8	15		13		12		11	
1000	1041	10	22				16.5		14.5		13		12	
1100	1044	10	23.5				18		15.5		14		13	
1200	1246	10	25				19.5		17		15		13.5	
1350	1400	12	27.5				21.5		18.5		16.5		15	
1500	1554	12	30				23.5		20.5		18		16.5	
1600	1650	15					25	23.5	22	20.5	19	18	17.5	16
1650	1701	15					25.5	24	22.5	21	19.5	18.5	18	16.5
1800	1848	15					28	26	24	22.5	21	20	19.5	18
2000	2061	15					30.5	28.5	26.5	25	23.5	22	21	19.5
2100	2164	15					32	30	28	26	24.5	23	22	20.5
2200	2280	15					33.5	31	29	27	25.5	24	23	21.5
2400	2458	15					36.5	34	31.5	29.5	27.5	26	25	23
2600	2684	15					39.5	36.5	34	31.5	29.5	28	27	25

**Steel**

Name		Tubing Type Carbon	Water Works Typ Zinc	Water Circulation Type TOFUKUSO Steel				Pressure Line Type Carbon Steel Pipe				Tubing Type Stainless Steel Pipe				
JIS		JIS G3452-1988	JIS G3442-1988	JIS G3443-1987				JIS G3454-1988				JIS G34T9-1988				
Material		STP	SGP-W	STW				STPG				SUS***TP, SUS***HTP, SUS***LTP, SUS***HTP				
Type				STW290	STW370	STW400A	STW400B	Schedule 10	Schedule 20	Schedule 30	Schedule 40	Schedule 5	Schedule 10	Schedule 20	Schedule 40	
Nominal	Outer Dia.															
25	34	3.2	3.2								3.4	1.65	2.8	3	3.4	
32	42.7	3.5	3.5								3.6	1.65	2.8	3	3.6	
40	48.6	3.5	3.5								3.7	1.65	2.8	3	3.7	
50	60.5	3.8	3.8						3.2		3.9	1.65	2.8	3.5	3.9	
65	76.3	4.2	4.2						4.5		5.2	2.1	3	3.5	5.2	
80	89.1	4.2	4.2	4.2	4.5				4.5		5.5	2.1	3	4	5.5	
90	101.6	4.2	4.2						4.5		5.7	2.1	3	4	5.7	
100	114.3	4.5	4.5	4.5	4.9				4.9		6	2.1	3	4	6	
125	139.8	4.5	4.5	4.5	5.1				5.1		6.6	2.8	3.4	5	6.6	
150	165.2	5	5	5	5.5				5.5		7.1	2.8	3.4	5	7.1	
175	190.7	5.3														
200	216.3	5.8	5.8	5.8	6.4				6.4	7	8.2	2.8	4	6.5	8.2	
225	241.8	6.2														
250	267.4	6.6	6.6	6.6	6.4				6.4	7.8	9.3	3.4	4	6.5	9.3	
300	318.5	6.9	6.9	6.9	6.4				6.4	8.4	10.3	4	4.5	6.5	10.3	
350	355.6	7.9				6		6.4	7.9	9.5	11.1				11.1	
400	406.4	7.9				6		6.4	7.9	9.5	12.7				12.7	
450	457.2	7.9				6		6.4	7.9	11.1	14.3				14.3	
500	508	7.9				6		6.4	9.5	12.7	15.1				15.1	
550	558.8							6.4	9.5	12.7	15.9				15.9	
600	609.6					6		6.4	9.5	14.3					17.5	
650	660.4							7.9	12.7						18.9	
700	711.2					7	6									
750	762															
800	812.8					8	7									
900	914.4					8	7									
1000	1016					9	8									
1100	1117.6					10	8									
1200	1219.2					11	9									
1350	1371.6					12	10									
1500	1524					14	11									
1600	1625.6					15	12									
1650	1676.4					15	12									
1800	1828.8					16	13									
1900	1930.4					17	14									
2000	2032					18	16									
2100	2133.6					19	16									
2200	2235.2					20	16									
2300	2336.8					21	17									
2400	2438.4					22	18									
2500	2540					23	18									
2600	2641.6					24	19									
2700	2743.2					25	20									
2800	2844.8					26	21									
2900	2946.4					27	21									
3000	3048					29	22									

**KUBOTA FW Pipe, Vinyl Pipe, Polyethylene Pipe**

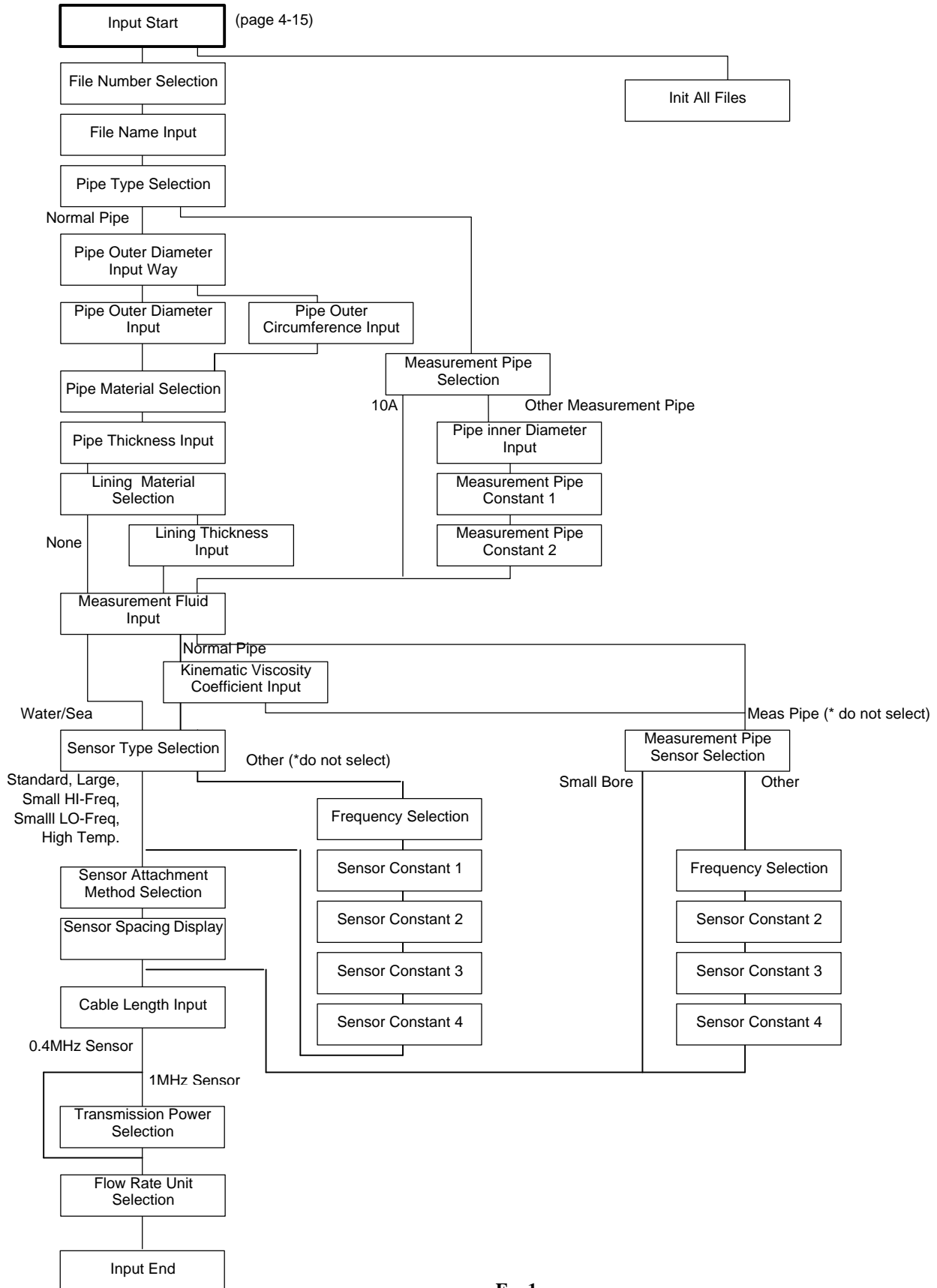
Name			KUBOTA FW Pipe		
JIS Number			JIS A5350		
Material			FRPM		
Type					
Nominal Dia.	Outer Dia.	Pipe Thickness			
150					
200					
250					
300					
400					
450					
500					
600	624	12			
700	728	14			
800	832	16			
900	936	18			
1000	1040	20			
1100	1144	22			
1200	1248	24			
1350	1404	27			
1500	1560	30			
1650	1716	33			
1800	1872	36			
2000	2080	40			
2200	2288	44			
2400	2496	48			
2600	2704	52			
2800	2912	56			
3000	3120	60			

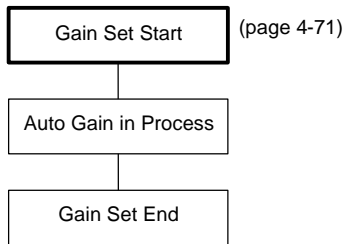
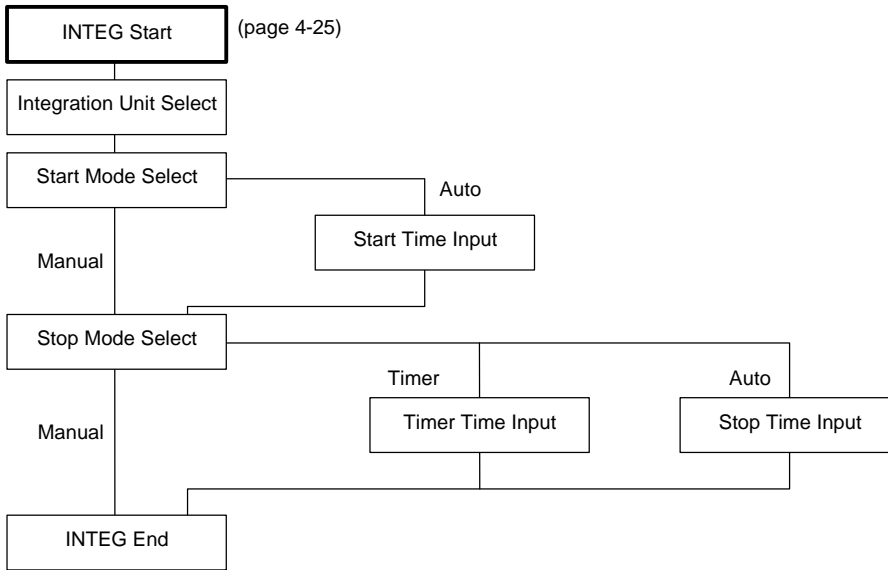
Name				Vinyl Pipe	
JIS Number				JIS K6741-1984	
Material					
Type				VP	VU
Nominal Dia.	Outer Dia.				
25	32			3.5	
30	38			3.5	
40	48			4	2
50	60			4.5	2
65	76			4.5	2.5
75	89			5.9	3
100	114			7.1	3.5
125	140			7.5	4.5
150	165			9.6	5.5
200	216			11	7
250	267			13.6	8.4
300	318			16.2	9.9
350	370				11.2
400	420				12.6
450	470				14.1
500	520				15.6
600	630				19.2
700	732				22.6
800	835				25.8

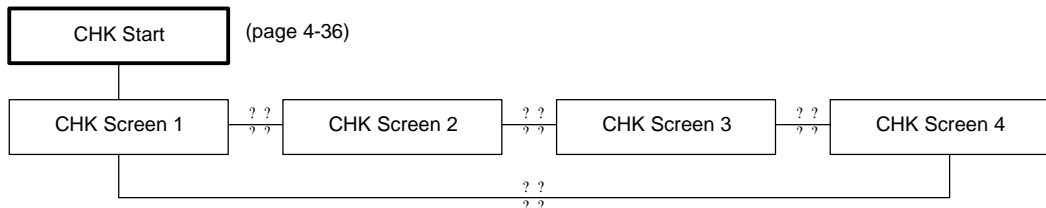
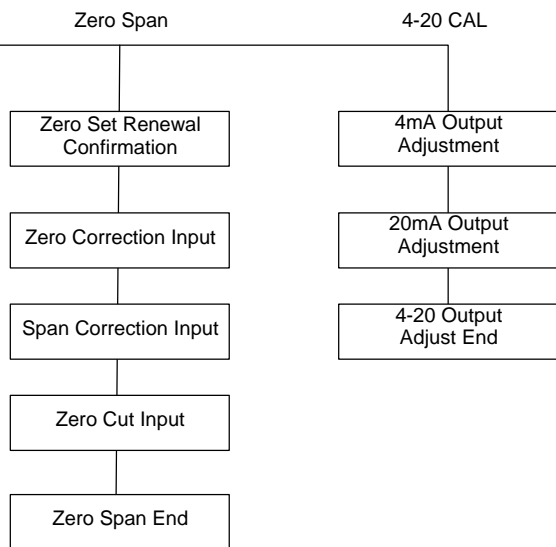
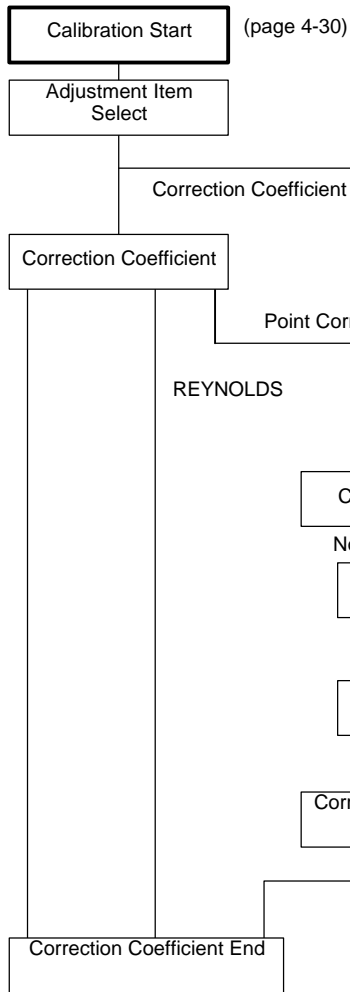
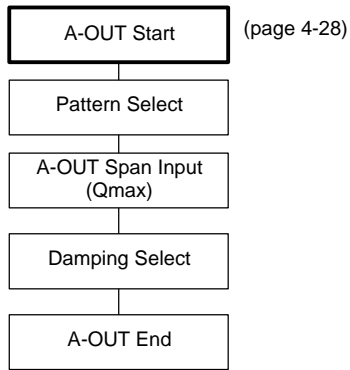
Name				Polyethylene Pipe	
JIS Number				JIS K6761-1979	
Material					
Type					
Nominal Dia.	Outer Dia.				
25	34			3	2.6
30	42			3.5	2.8
40	48			3.5	3
50	60			4	3.5
65	76			5	4
75	89			5.5	5
100	114			6	5.5
125	140			6.5	6.5
150	165			7	7
200	216			8	8
250	267			9	9
300	318			10	10

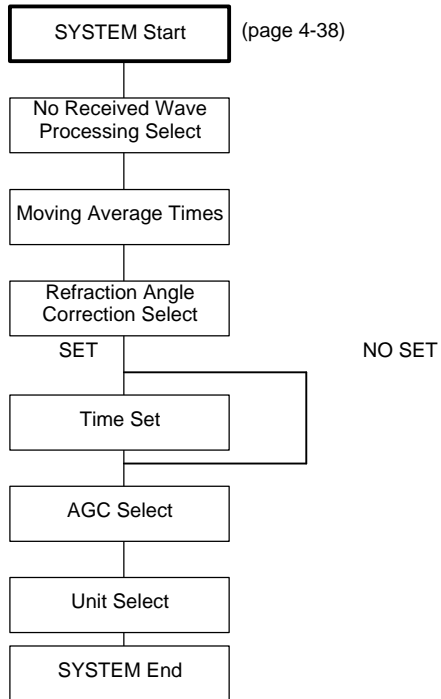
# Appendix E

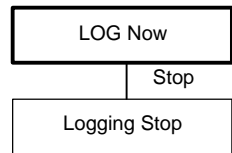
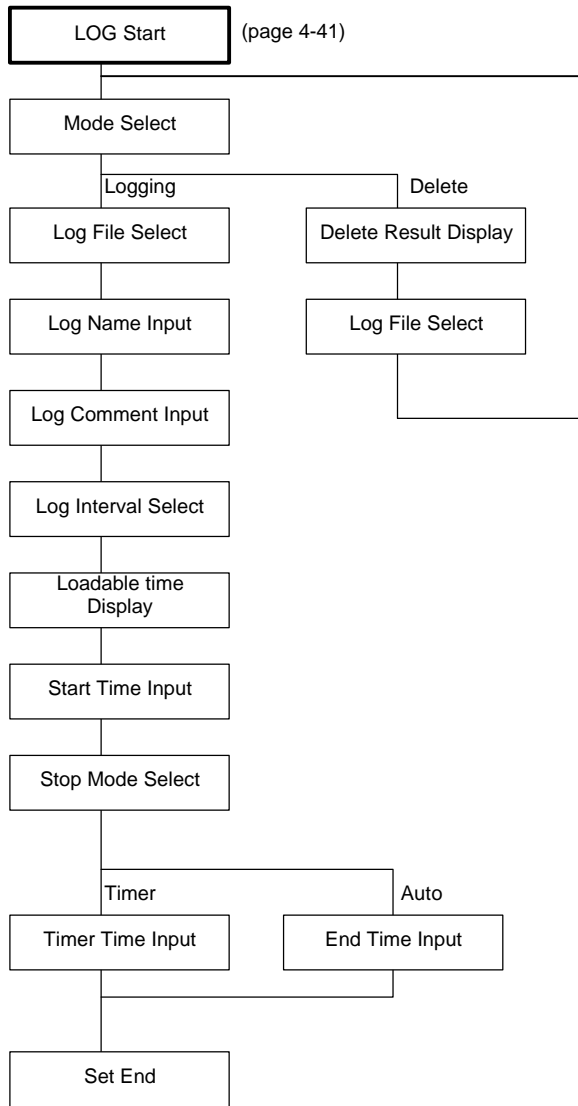
## Menu Flowchart

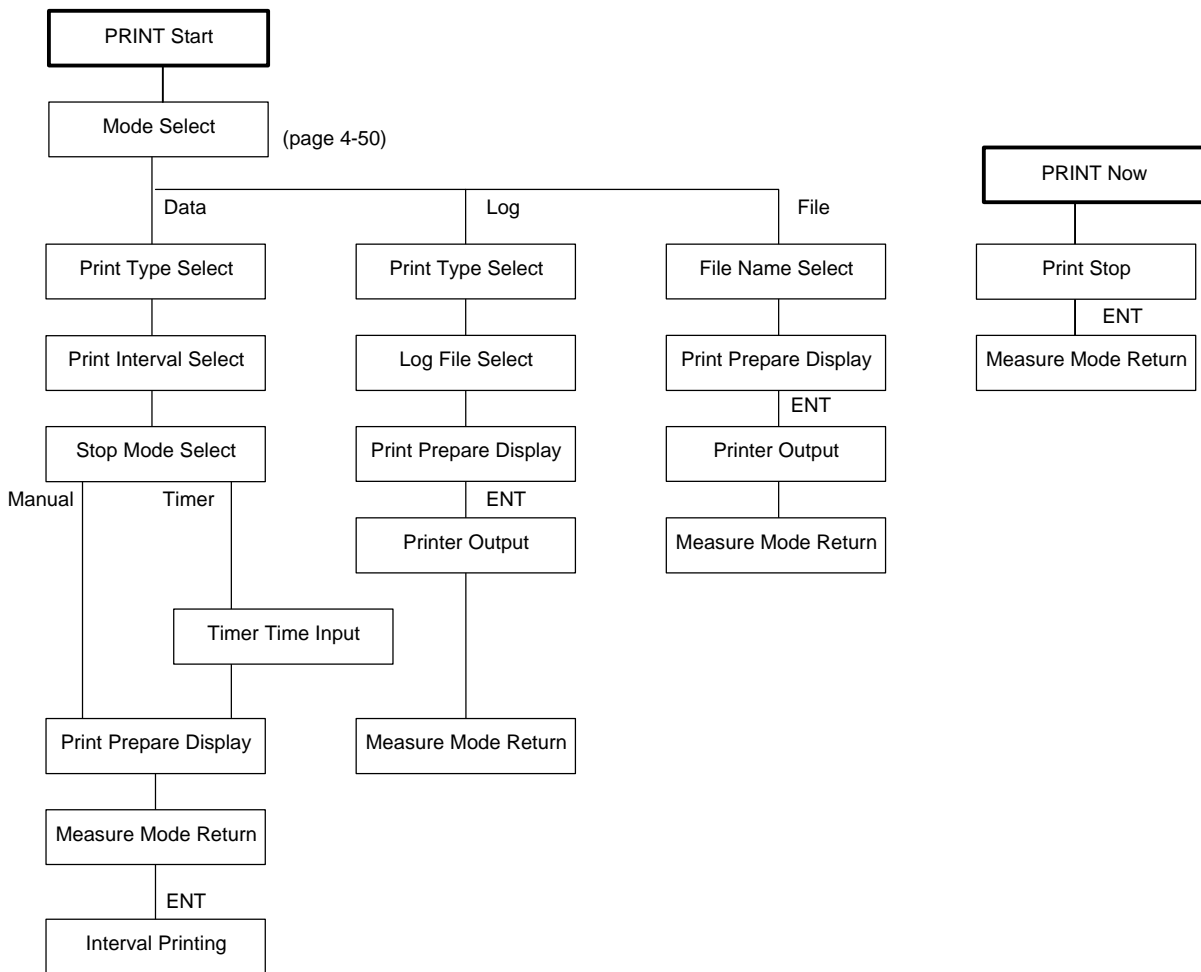
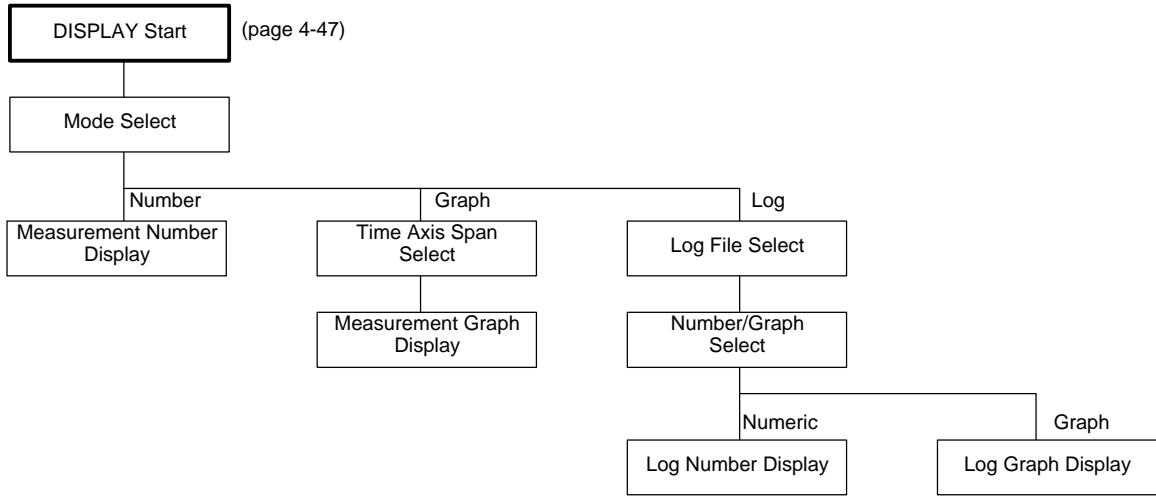






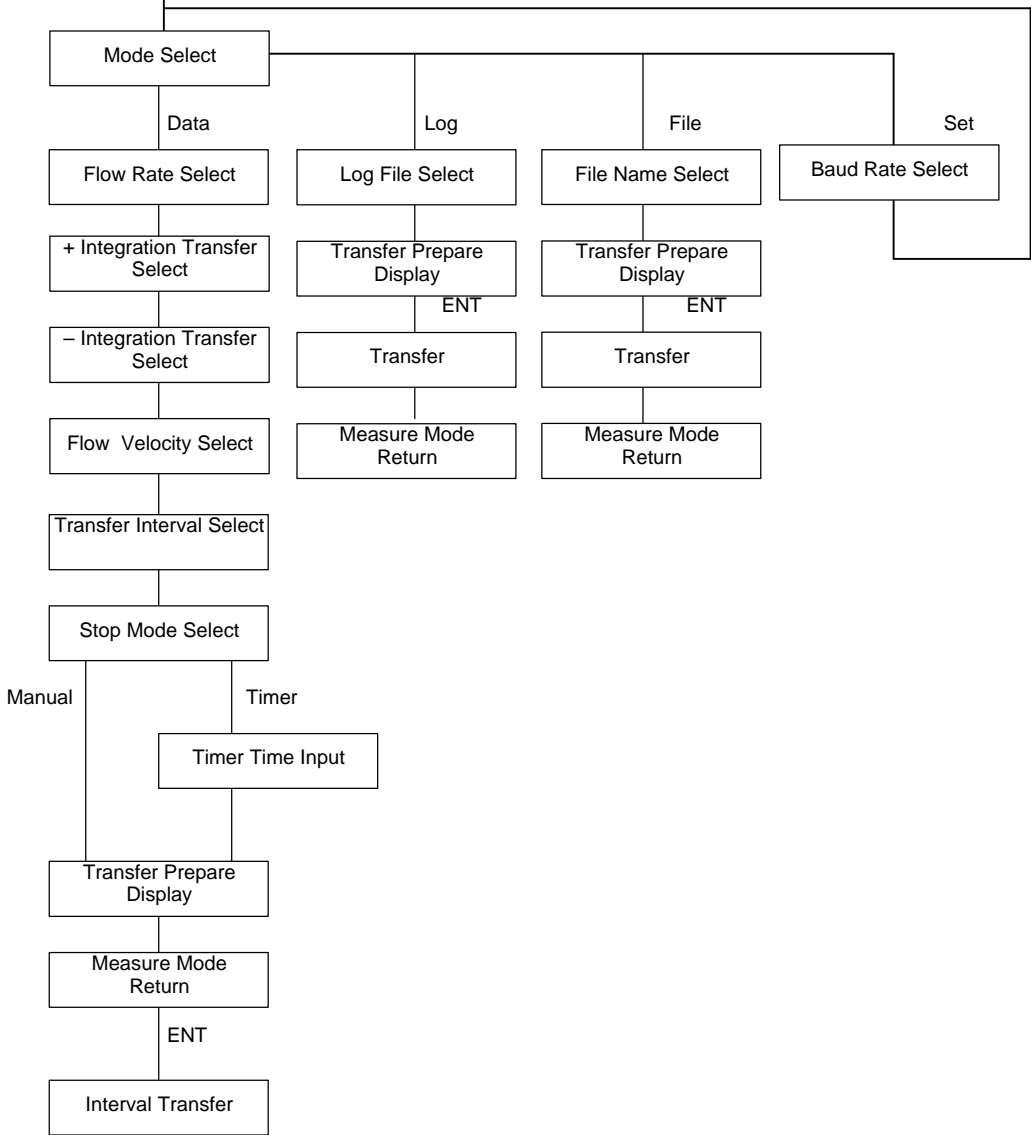




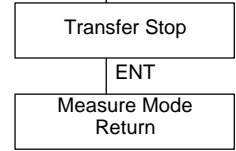


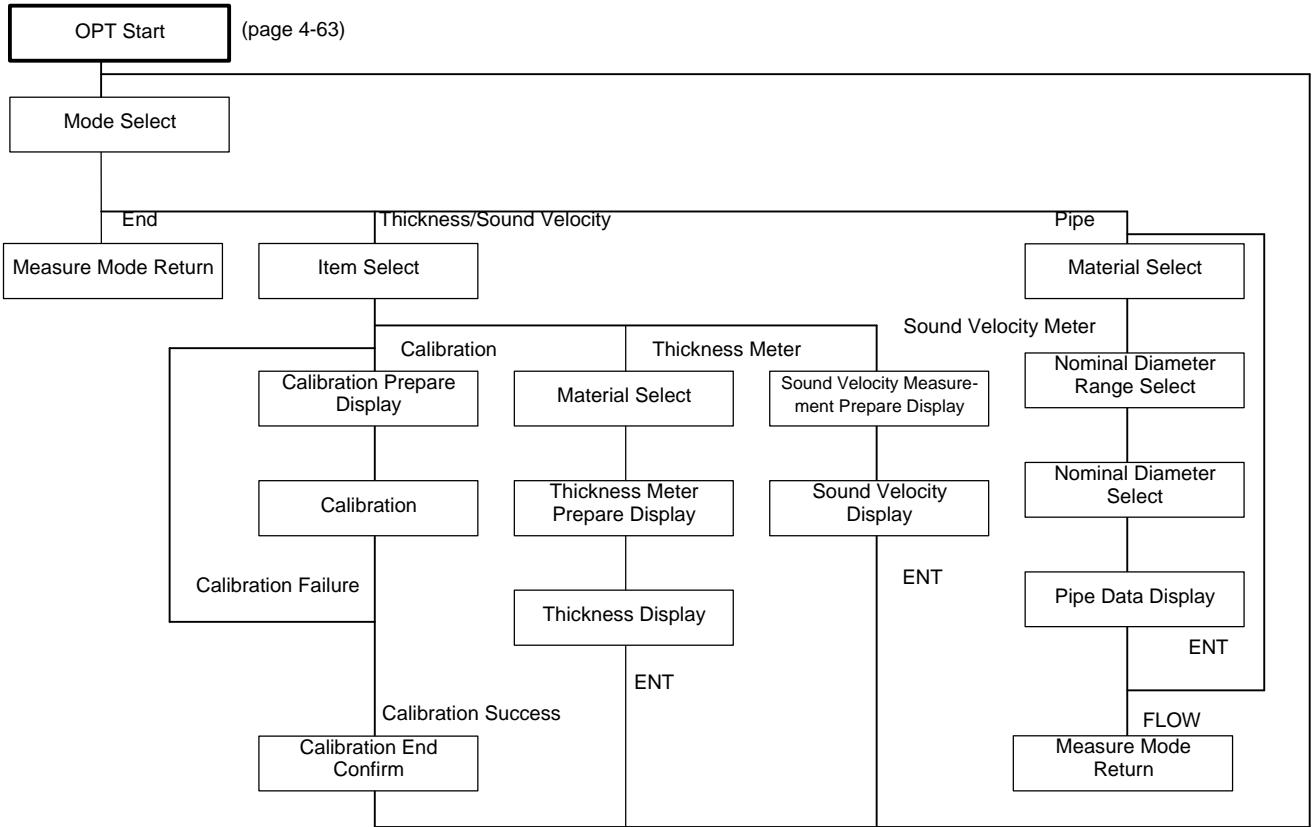
**TRANS Start**

(page 4-57)



**TRANS Now**





## Appendix F

### Error Code

Error codes are displayed in the upper left corner of the LCD screen.

\* mark indicates the point of error.

Example: "E9" display indicates an "AGA Error" and "R-OFF Error".

Error Code	AGA Error	AGC Error	Abnormal Value Error	R-OFF Error (No Received Echo Error)
E1				*
E2			*	
E3			*	*
E4		*		
E5		*		*
E6		*	*	
E7		*	*	*
E8	*			
E9	*			*
E10	*		*	
E11	*		*	*
E12	*	*		
E13	*	*		*
E14	*	*	*	
E15	*	*	*	*

**AGA Error :** An appropriate gain could not be determined with the AGA operation.  
There were air bubbles or something present during the procedure causing an unstable echo level or the pipe wall is deteriorated (rust, etc.) where the sensors are attached, interfering with the ultrasonic wave transmission and reception. Perform the AGA procedure again as is, or reattach the sensors and perform the AGA procedure again.  
Also, confirm the cable connection.

**AGC Error :** Right after the AGA procedure determined the gain AGC attempted to determine the Reference Level, however the echo level changed drastically so that the reference level could not be determined.  
This error is caused by air bubbles or a sudden change in flow speed. Stabilize the flow and perform the AGA again.

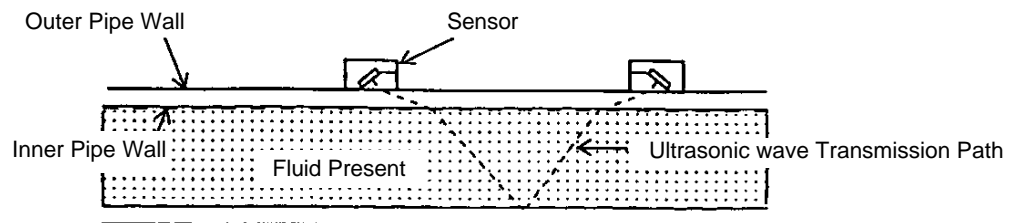
**Abnormal Value Error :**

During the flow measurement, data was measured that was drastically different from the prior data. This data was determined to be in error and was deleted resulting in this error display. This error is usually caused by a valve being opened up stream temporarily changing the flow speed or by air bubbles.

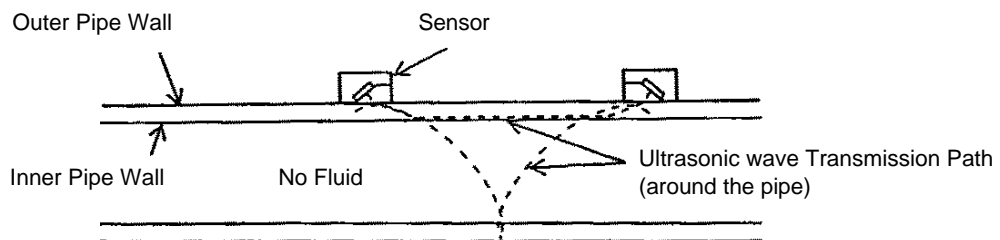
**R-OFF Error (No Received Echo Error) :**

This error indicates that the reception echo was not received in series. If interference is large and an adequate echo level can not be received this error message will display.

Usually an R-OFF error indicates no fluid in the pipe causing the ultrasonic wave to deviate from the correct transmission path where the echo could not be received.



However, there are times when there is no fluid present that the ultrasonic wave will transmit through the pipe wall to the reception sensor. If the distance of the sensors is such that this quasi-echo reaches the sensor at approximately the same time as a correct echo would be received the quasi-echo is mistaken for the real echo and no R-OFF error is displayed even though it is in error.



## Appendix G

### Mode (key) Permission

Marks in the following table and Meaning are:

Enable to operate and current mode continues

Enable to operate but current mode stops

x Disable to operate

Mode	Key										
	OFF	GAIN	FLOW	INPT	INTG	ARROW	AOUT	CAL	CHK	SYS	#(MULTI)
AGA		x		x	x	x	x	x	x	x	x
FLOW			x			x					
INPUT		x		x	x		x	x	x	x	x
INTEG Setting		x		x	x		x	x	x	x	x
INTEG Standby		x	x	x		x	x	x		x	x
INTEG		x	x	x		x	x	x		x	x
CHK		x		x	x		x	x	x	x	x
LOG Setting		x		x	x		x	x	x	x	x
LOG Standby		x	x	x	x	x	x	x		x	x
LOG		x	x	x	x	x	x	x		x	x
DISP trend/log		x		x	x		x	x	x	x	x
PRINT Setting		x		x	x		x	x	x	x	x
PRINT		x	x	x	x	x	x	x		x	x
TRANS Setting		x		x	x		x	x	x	x	x
TRANS		x	x	x	x	x	x	x		x	x
OPT		x	x	x	x		x	x	x	x	x

(continue to next page)

(continue from previous page)

Enable to operate and current mode continues

Enable to operate but current mode stops

Either one enable

× Disable to operate

Enable for integration start / stop

Mode	Key										
	LOG	DSP	PRNT	TRNS	numeric	STOP	STRT	OPT	EXIT	CLR	ENT
AGA	×	×	×	×	×	×	×	×	×	×	
FLOW					×				×	×	×
INPUT	×	×	×	×		×	×	×			
INTEG Setting	×	×	×	×		×	×	×		×	
INTEG Standby					×	×	×	×	×	×	×
INTEG					×		×	×	×	×	×
CHK	×	×	×	×	×	×	×	×	×	×	×
LOG Setting	×	×	×	×		×	×	×		×	
LOG Standby					×			×	×	×	×
LOG					×			×	×	×	×
DISP trend/log	×	×	×	×	×	×	×	×	×	×	×
PRINT Setting	×	×	×	×		×	×	×		×	
PRINT				×	×			×	×	×	×
TRANS Setting	×	×	×	×		×	×	×		×	
TRANS			×		×			×	×	×	×
OPT	×	×	×	×		×	×	×			

#### Note

~~EE~~ In the INPUT mode, GAIN key is disable except last step of INPUT mode.

~~EE~~ In the OPT mode, the operation for LCD backlight on/off doesn't work. If necessary, turn it on in the FLOW mode.

~~EE~~ LCD light and shade adjustment is performed in the FLOW mode only.

## Appendix H

### Parameter dependance

parameters depending upon the Pipe data file (Mode)	parameters in System common (Mode)
<ul style="list-style-type: none"> <li><del><del> Pipe data file name (INPUT)</del></del></li> <li><del><del> Pipe type (INPUT)</del></del></li> <li><del><del> Pipe outer diameter (INPUT)</del></del></li> <li><del><del> Pipe material / sound velocity (INPUT)</del></del></li> <li><del><del> Pipe thickness (INPUT)</del></del></li> <li><del><del> Lining material / sound velocity (INPUT)</del></del></li> <li><del><del> Lining thickness (INPUT)</del></del></li> <li><del><del> Measured fluid / sound velocity (INPUT)</del></del></li> <li><del><del> Coefficient of kinematic viscosity of fluid (INPUT)</del></del></li> <li><del><del> Used sensor (INPUT)</del></del></li> <li><del><del> Sensor constant (INPUT)</del></del></li> <li><del><del> Sensor installation method (INPUT)</del></del></li> <li><del><del> Cable length (INPUT)</del></del></li> <li><del><del> Flow rate unit (INPUT)</del></del></li> <li><del><del> No received echo processing (SYSTEM)</del></del></li> <li><del><del> Moving averaging times (SYSTEM)</del></del></li> <li><del><del> Refraction angle correction (SYSTEM)</del></del></li> <li><del><del> Integration unit (INTEG)</del></del></li> <li><del><del> A-out pattern (AOUT)</del></del></li> <li><del><del> A-out span (AOUT)</del></del></li> <li><del><del> A-out damping (AOUT)</del></del></li> <li><del><del> Volume (flow rate) correction (CAL)</del></del></li> <li><del><del> Zero set (CAL)</del></del></li> <li><del><del> Zero correction (CAL)</del></del></li> <li><del><del> Span correction (CAL)</del></del></li> <li><del><del> Zero cut (CAL)</del></del></li> <li><del><del> AGA setting value (GAIN)</del></del></li> <li><del><del> AGC reference</del></del></li> </ul>	<ul style="list-style-type: none"> <li><del><del> AGC setting (SYSTEM)</del></del></li> <li><del><del> Time (SYSTEM)</del></del></li> <li><del><del> A-out calibration (CAL)</del></del></li> <li><del><del> Logging file name (LOG)</del></del></li> <li><del><del> Logging sampling time (LOG)</del></del></li> <li><del><del> Logging start time (LOG)</del></del></li> <li><del><del> Logging stop time (LOG)</del></del></li> <li><del><del> Print mode baud rate (Fixed)</del></del></li> <li><del><del> Transmission mode baud rate (TRANS)</del></del></li> <li><del><del> integration start mode (INTEG)</del></del></li> <li><del><del> integration start time (INTEG)</del></del></li> <li><del><del> integration stop mode (INTEG)</del></del></li> <li><del><del> integration stop time (INTEG)</del></del></li> <li><del><del> LCD back light (B/L)</del></del></li> <li><del><del> LCD light and shade</del></del></li> </ul>

## Appendix I

### Function Comparison of Version 2.0E and previous version

Function	Previous Ver. (~V1.3E)	Ver. 2.0E
Contents of output data in TRANS mode & PRINT mode	Flow Rate,+ Integration, – Integration	Flow Rate,+ Integration,– Integration, Flow Velocity
Display format of the size of memory available for logging	The total number of free blocks is shown.	The total time available for logging is shown.
Display of current date and time in LOG menu and INTEG menu	None	Displayed
Operation in LOG menu,PRINT menu ,and TRANS menu	_____	Improved
Interruption of data output in LOG mode	Unavailable	Available
Key operation for file name input	_____	Improved (Operation & Screen format)
Initialization of pipe data file	0 + Power[ON]	0 + Power[ON] and It's available in INPUT menu.
The way to input a pipe size	Direct input of the Outside diameter	Direct input of the outside diameter or the circumference.

---

ULTRASONIC FLOWMETER  
Model UFP-10  
Operation Manual  
[Document no. KF96-001J]  
(The content is used in ver. 2.24 or later)

---

April, 1996      First Edition  
June, 2006      Eleventh Edition

---

**TOKIMEC INC.**  
2-16-46, MINAMI-KAMATA,  
OHTA-KU, TOKYO 144-8551, JAPAN  
CONTROL DIVISION  
Tel. (81) 3-3737-8621  
Fax. (81) 3-3737-8665

---

Notice : This operation manual must not be copied or reproduced without the expressed written permission of TOKIMEC.