

Document No.: KF05-001C

MRG-10
User's Guide

July 2008

TOKIMEC INC.
Control Division 1

Safety Cautions

The caution message shown in the User's Guide is defined as follows:

 <p>Warning</p>	<p>Indicates that incorrect usage may result in death or serious injury to the operator.</p>
--	--

 <p>Caution</p>	<p>Indicates that incorrect usage may result in injury to the operator or damage to the equipment.</p>
--	--

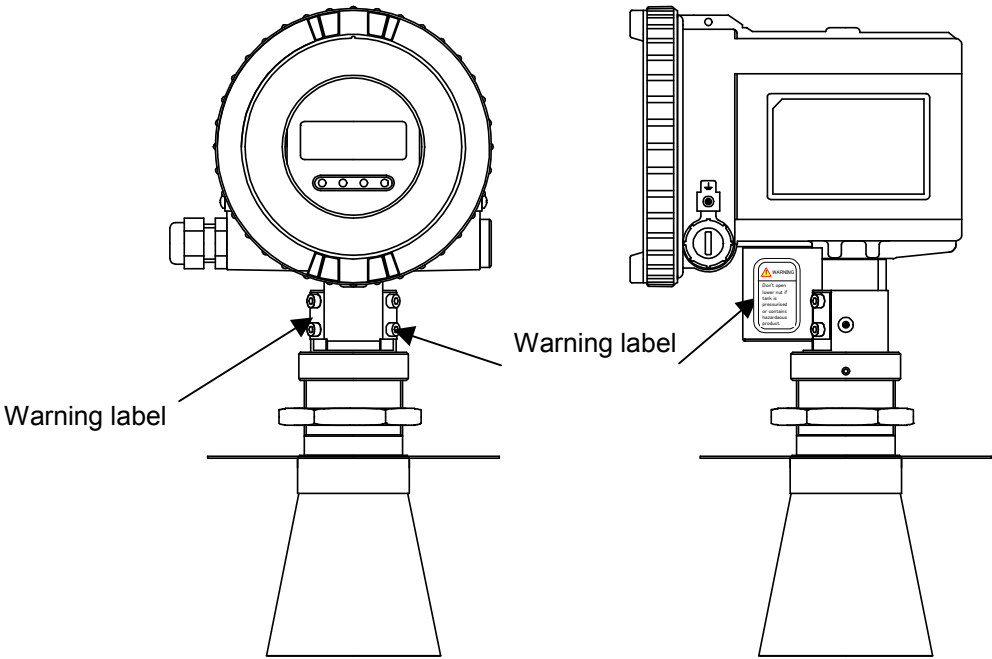

Introduction

This User's Guide includes detailed explanations of MRG-10 safety cautions, installation, configuration, and troubleshooting. Users should carefully read this manual before operation to ensure an adequate understanding of the equipment.

Proper use of the User's Guide

The following points must be observed:

- (1) Carefully read the User's Guide
The contents of the User's Guide are very important. Carefully read the entire manual.
- (2) Store the User's Guide in safe location.
The User's Guide is very important for the operation of the equipment. Store the manual in a safe and accessible location. The storage location and person responsible for maintaining the Guide should be considered carefully.
- (3) Ensure that the User's Guide is supplied to the operator of the equipment.
The representative or dealer of this equipment must supply this User's Guide to the user who will actually operate the equipment.
- (4) The User's Guide should be replaced if it is lost.
If the User's Guide is lost, contact the representative listed on the back cover. A new manual may be purchased.

Restrictions and cautions necessary to maintain the equipment

The following items must be observed to ensure that the equipment is maintained properly. Refer to the pages corresponding to each topic for details. The corresponding pages are shown in () brackets.

- (1) Do not drop unit or subject unit to impact.
- (2) Use the unit in appropriate temperature environments.
(Refer: p.6-2 Operating condition)
- (3) Use the unit under appropriate process temperature and pressure.
(Refer: p.6-2 Operating condition)
- (4) Always use an appropriate power supply.
(Refer: p.6-1 Power Supply voltage)
- (5) Do not loosen union nut when tank is pressured.
(Refer: p.2-5 Mounting the cone antenna)

Contents

About this manual

1.Product Description	1-1
1.1 Features	1-1
1.2 Measuring principle	1-1
1.3 MRG-10 measuring system	1-2
2.Mechanical Installation	2-1
2.1 Requirements	2-1
2.2 Dimensions	2-4
2.3 Tools	2-5
2.4 Mounting Cone Antenna	2-6
2.5 Mounting Rod Antenna	2-8
2.6 Installation Hints	2-10
3.Electrical Installation	3-1
3.1 Connection of MRG-10	3-1
3.2 Cables	3-2
3.3 Load	3-2
3.4 Power Supply	3-2
3.5 Grounding	3-2
3.6 Arrester replacement	3-3
4.Configuration method	4-1
4.1 Display Panel & Key SW	4-1
5.Configuration	5-1
5.1 Basic Settings	5-1
5.2 Negative level point measurement	5-3
5.3 Avoiding Disturbance Echoes	5-3
5.4 Volume calculation	5-7
5.5 Analog value compensation	5-8
5.6 Measuring value compensation	5-8
5.7 Bottom recognition	5-9
5.8 Other	5-9
5.9 Pipe antenna setting	5-9
5.10 Key Parameter List	5-11
6.Technical Information	6-1
7.Troubleshooting	7-1

About this manual

This User's Guide provides information about mechanical and electrical installation of the MRG-10. It also describes how to configure the unit.

The main purpose of the book is to serve as a guide to installing and operating the MRG-10. It is not intended to cover service tasks such as changing circuit boards or internal software.

Chapter 1 reviews some basic concepts of radar based level gauging.

Chapter 2 describes how to assemble a gauge and how to mount it onto a tank.

Chapter 3 describes electrical installation.

Chapter 4 describes configuration method by key SW.

Chapter 5 describes how to configure for tank conditions.

Chapter 6 provides technical information.

Chapter 7 lists some typical problems that might occur and suggestions on how to solve them.

1 1 Product Description

The MRG-10 is a loop-powered radar level gauge, which can be installed easily in a variety of applications. The MRG-10 employs a non-contact radar level gauging principle based on pulsed microwave signals and is suitable for level measurement in applications such as liquids, pastes and slurries.

MRG-10 uses 5.8GHz low power pulsed microwave. It provides good measurement stability, because propagation of microwaves is not affected by temperature, pressure or gas conditions in tank.

1.1 Features

MRG-10

MRG-10 needs only a two-wire cable for power supply and output signal.

Communication

MRG-10 incorporates HART® protocol function which superimposes a digital output signal on the 4-20mA current output signal. Settings can be made by a HART® communicator or PC-based setup software.

Volume calculation function

Volume calculation function is based level measurement of the remaining liquid in the tank and the formula takes into consideration three tank configurations - spherical, vertical cylinder and horizontal cylinder. There is also an applicable user-defined 20-step table.

1.2 Measuring principle

The MRG-10 level gauge utilizes the time-of-flight measurement principle involving short microwave pulses. Installed at the top of tanks, it emits short microwave pulses toward liquids or pastes in the tank. Reflected microwave signals from the surface are received by the antenna, and processed by electronics. The time from transmission to reception is determined by the microprocessor and converted as distance from the transmitter to the liquid surface (ullage) with output of the calculated level from the measured ullage ($\text{Level} = \text{Tank Height} - \text{Ullage}$).

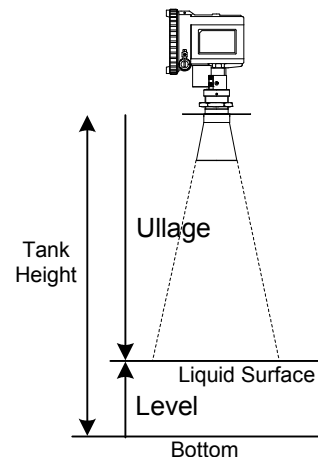

1.3 MRG-10 measuring system

MRG-10 can be configured with its onboard 4 key switches, a handheld terminal or remotely from a personal computer via a modem.

The MRG-10 is connected to a PLC or power supply unit.

Example Connection from power supply unit to MRG-10 mounted in non-hazardous area

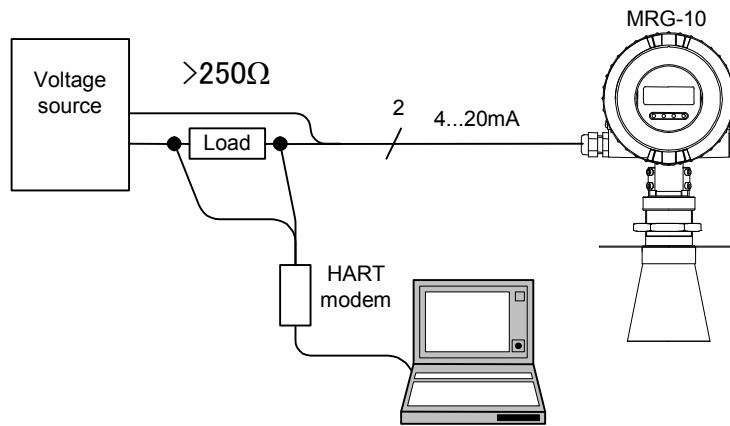

2 Mechanical Installation

2.1 Requirements

2.1.1 Cone antenna

Mounting position

Do not mount the transmitter at the center of the tank or close to the tank wall as this may reduce the measuring range or accuracy and make the transmitter more sensitive to echo disturbances. We recommend that the transmitter be mounted so that the antenna tip is located at least 0.6 m from the tank wall.

Socket requirements

The antenna tip should extend past the nozzle (10 mm or more).

If the antenna tip is located inside the nozzle, echo disturbances may be generated which will negatively affect measurement performance.

Free space requirements

The transmitter should be mounted so that no obstacles are present in the radar beam.

Obstacles in the radar beam may reduce the measuring range.

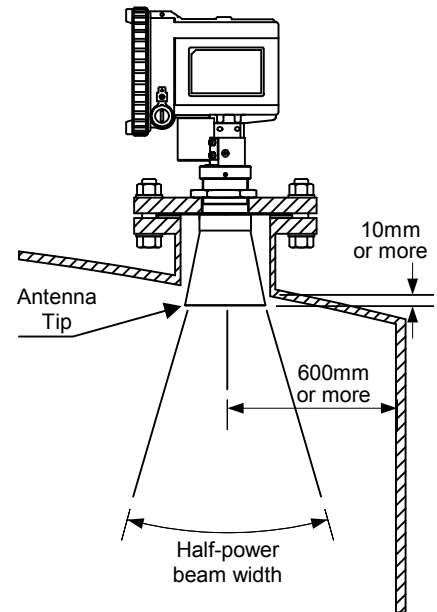

Antenna Type	Half Power Beam Width (Degrees)
4" cone	34
6" cone	22
8" cone	17
Rod	30

Half Power Beam Width.

Distance[m]	Antenna Type			
	4"cone	6"cone	8"cone	Rod
5m	2.9	1.9	1.5	2.7
10m	5.8	3.8	3.0	5.4
15m	8.8	5.7	4.4	8.0
20m	11.7	7.6	5.9	10.7

Diameter of radiated area (m).

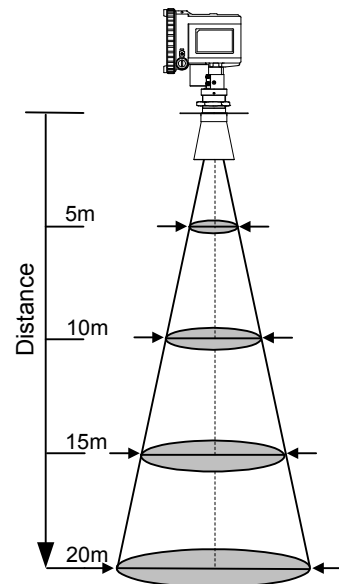

2.1.2 Rod antenna

Mounting position

Do not mount the transmitter at the center of the tank or too close to the tank wall as this may reduce the measuring range or accuracy and make the transmitter more sensitive to echo disturbances. We recommend that the transmitter be mounted so that the antenna tip is located at least 0.6m from the tank wall.

Socket requirements

There are 2 inactive zone lengths (100mm and 250mm). Noise reflections from the nozzle are avoided in these zones. Nozzle height must be less than the antenna extension.

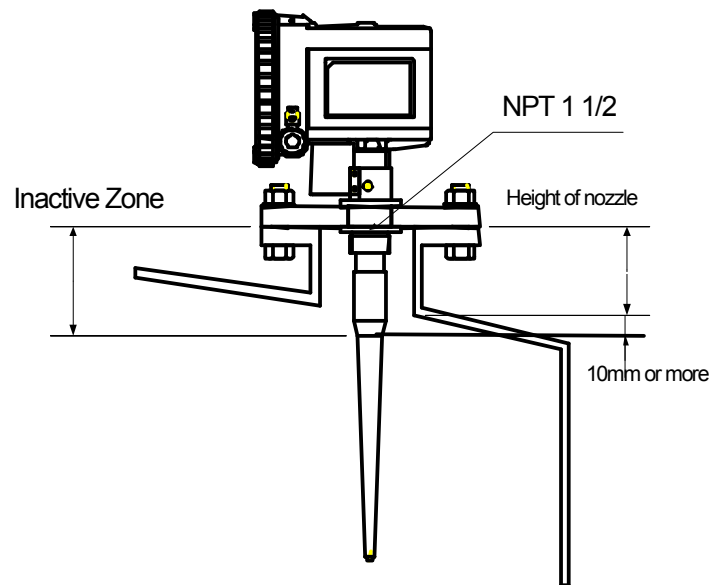

Free space requirements

The transmitter should be mounted so that no obstacles are present in the radar beam. Obstacles in the radar beam may reduce the measuring range.

2.1.3 Key factors for measurement

1. The strength of the microwave reflection from the liquid surface is proportional to the dielectric constant ϵ_r (Epsilon) of the target fluid. The higher the fluid's dielectric constant, the wider the measurable range.
2. A larger antenna enables more stable measurement and a wider measuring range.
3. Compared to calm fluid surfaces, measuring ranges of turbulent surfaces are reduced due to poorer reflection.
4. Deposit buildup on the antenna, foaming on liquid surfaces, powder granules in air suspension and other interior tank conditions may affect measuring range and performance.
5. Obstructions in the microwave radiating area or target fluid surface areas less than the radiating area will reduce microwave reflection and decrease and narrow the measurable range.

Maximum measuring distance

Maximum measurement distance is determined by antenna type, dielectric constant of the product and product surface conditions. Please refer to the table below. These values are rough estimates, and are strongly influenced by the measuring conditions.

Calm surface

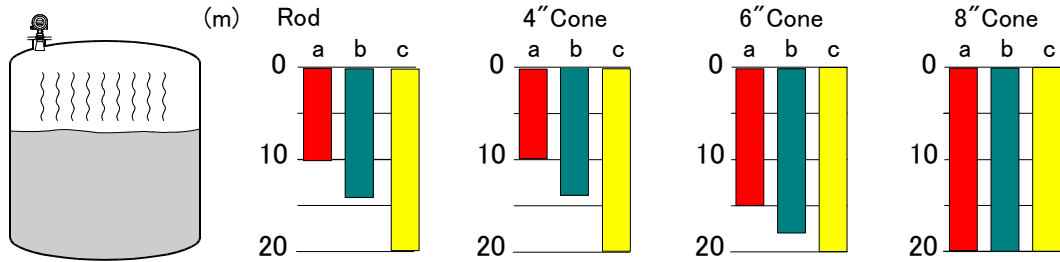

Turbulent surface

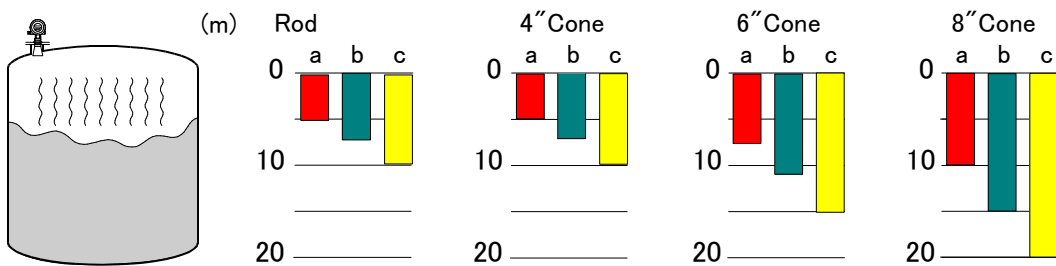

- a) Dielectric constant 1.9 - 4.0 Oil, gasoline and other hydrocarbons, petrochemicals
- b) Dielectric constant 4.0 - 10 Alcohol, concentrated acids, and organic solvents
- c) Dielectric constant >10 Water-based liquids, dilute acids and acetone

2.2 Dimensions

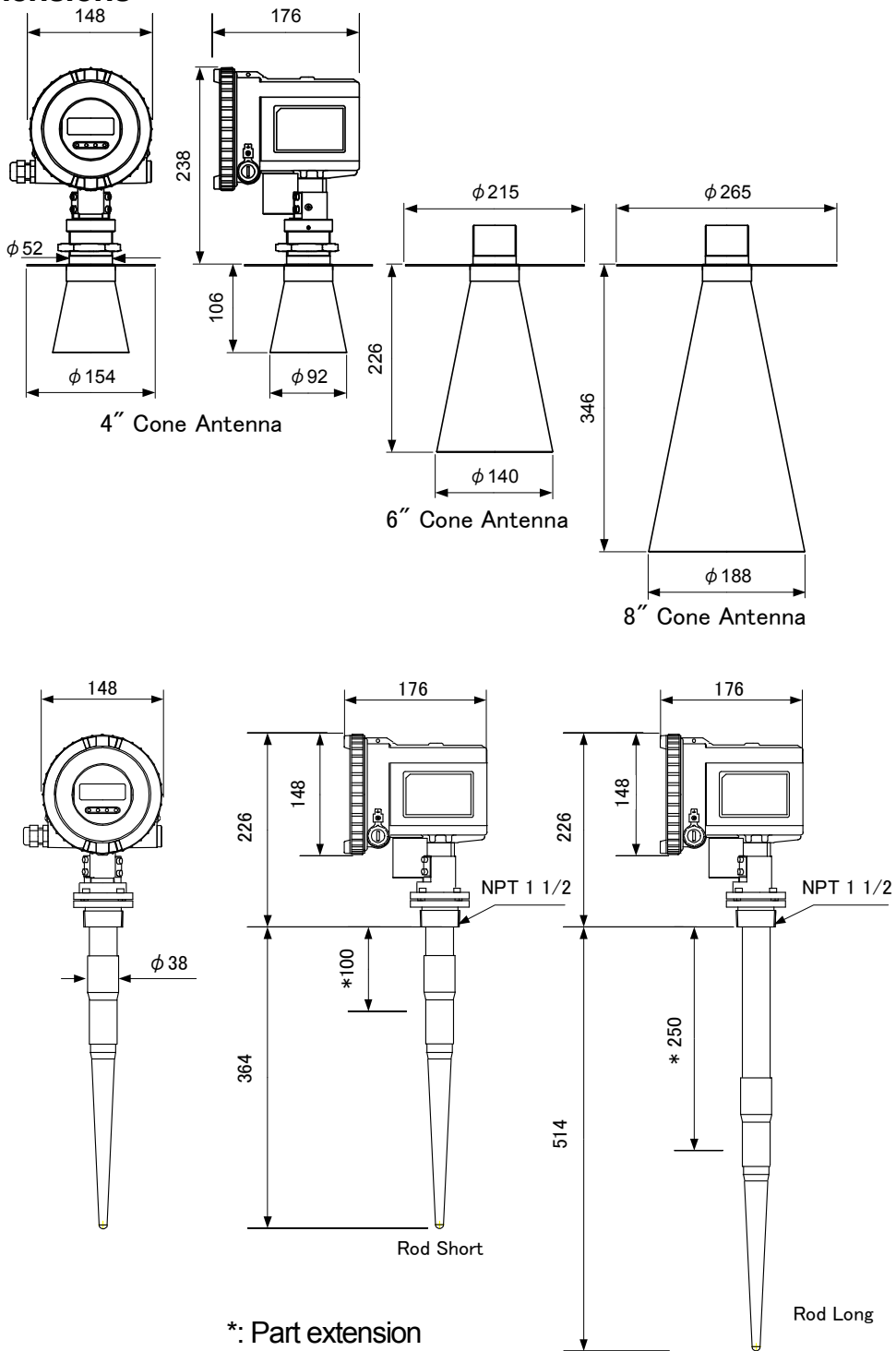

Weights

MRG-10(except antenna)	2.5 kg
4" Cone antenna	0.8 kg
6" Cone antenna	1.2 kg
8" Cone antenna	1.8 kg
MRG-10 with rod antenna short	3.4 kg
MRG-10 with rod antenna long	3.7 kg

Flange

The MRG-10 gauge is mounted with a flange of the following specifications:

Cone antenna

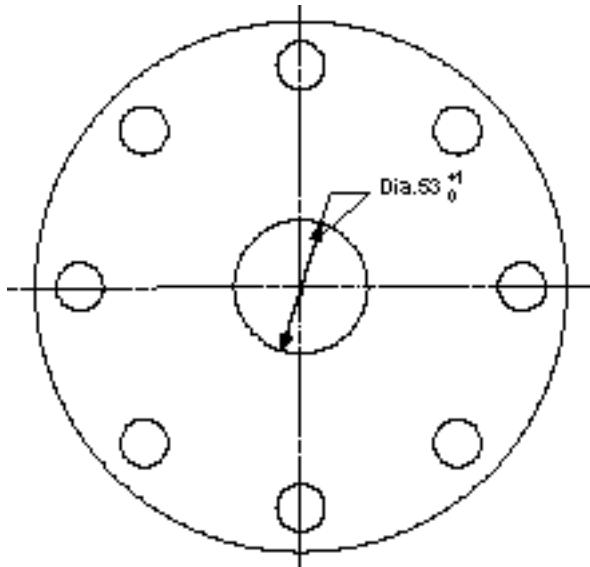

Rod antenna

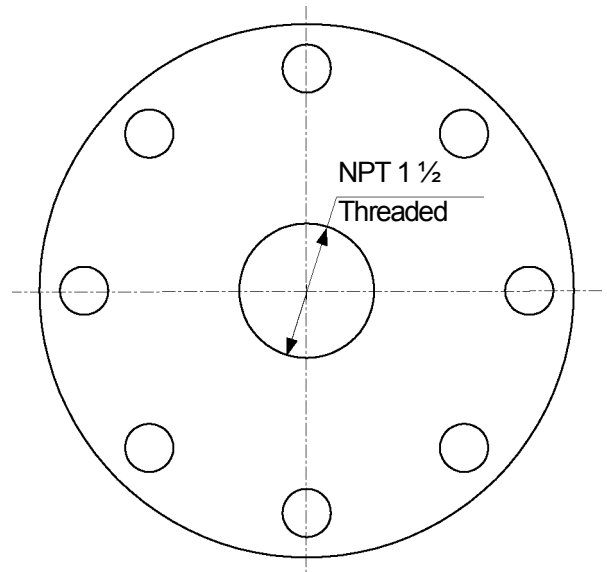

Maximum thickness : 29mm (ANSI Class-150 8").

2.3 Tools

The following tools are needed for installation of MRG-10:

- Hexagon socket screw keys(-4)
- Adjustable wrench (for locking nut)
- Pipe wrench (for neck of cone antenna)
- Screwdriver (-) width 3mm

2.4 Mounting the cone antenna



Warning

Do not damage the PTFE seal and O-ring during mounting. Damaged seals may cause gas leakage when the MRG-10 is installed on pressurized tanks.

1. Check and confirm the parts described below which are required for installation of the cone antenna.

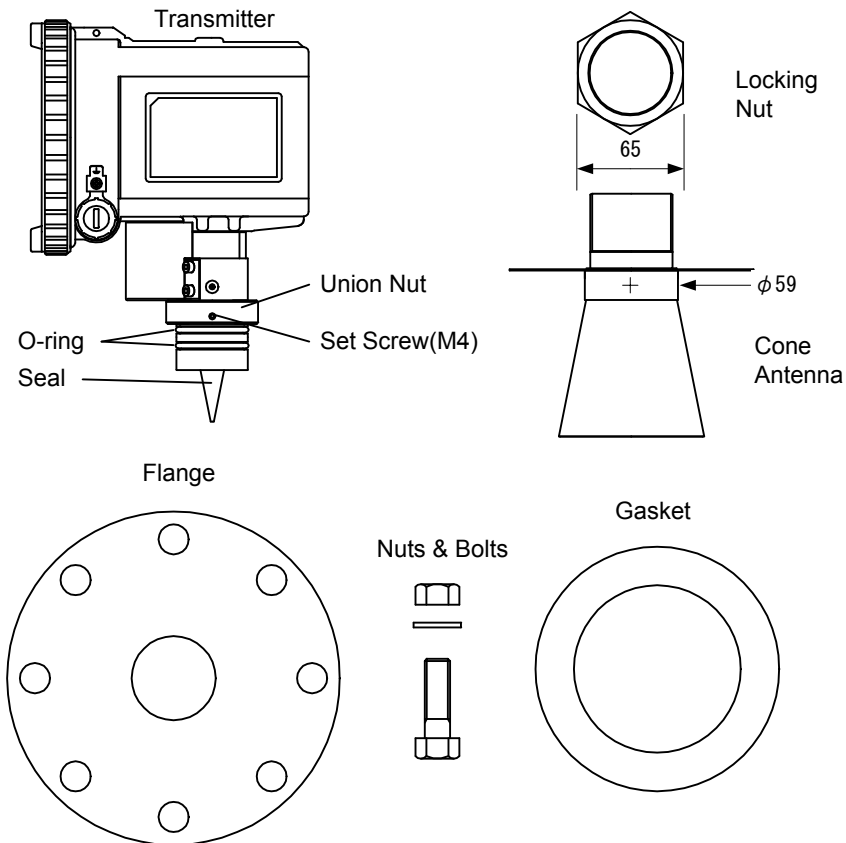



2. Mount the flange on top of the cone plate.
Secure the flange with the locking nut.
Make sure that the nut is fitted tightly to the flange.

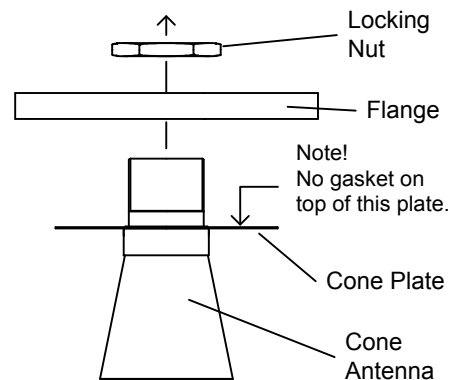

Warning

Make sure that the bottom side of the flange is flat and all parts are clean and dry as problems related to this may result in gas leakage when the MRG-10 is installed on pressurized tanks.



	<p>Warning</p>
<p>Make sure that the O-ring inside of the sleeve is clean as improper sealing may lead to gas leakage problems when the MRG-10 is installed on pressurized tanks.</p>	

- Carefully insert the antenna adapter of the transmitter into the sleeve. Secure the antenna adapter with the union nut. Make sure that the antenna adapter fits inside of the cone antenna. Secure the union nut with the set screw.

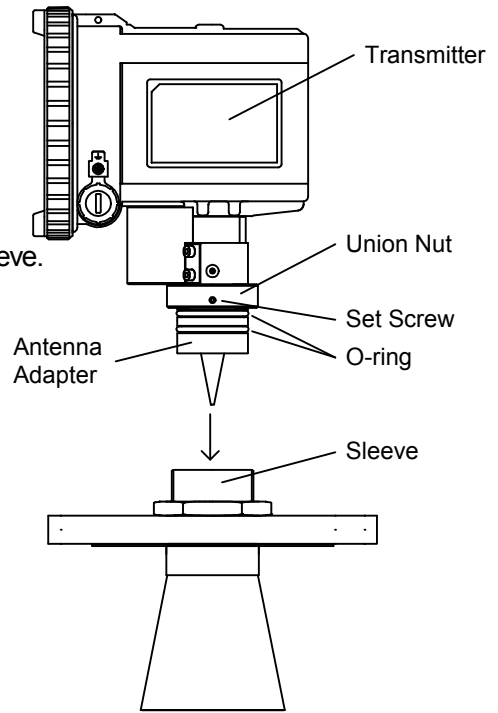

	<p>Warning</p>
<p>Do not loosen the union nut when the tank is pressurized.</p>	

- Place the gasket on the tank nozzle. Carefully fit the flange and the cone antenna on the tank nozzle. Tighten the assembly with the screws and nuts.

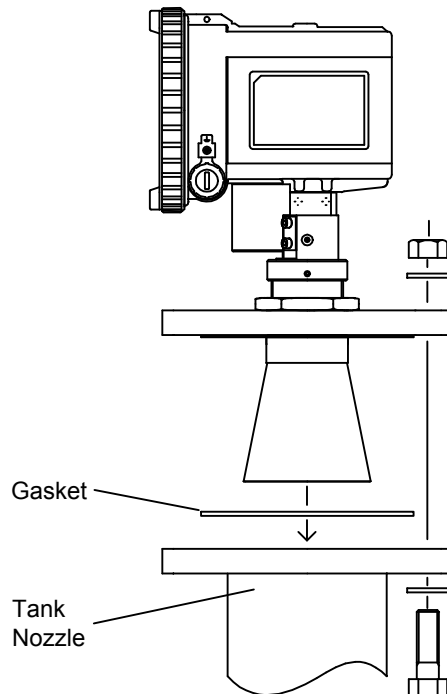

2.5 Mounting rod antenna



Warning

Do not damage antenna. Damaged antenna may cause gas leakage if the MRG-10 is installed on a pressurized tank.

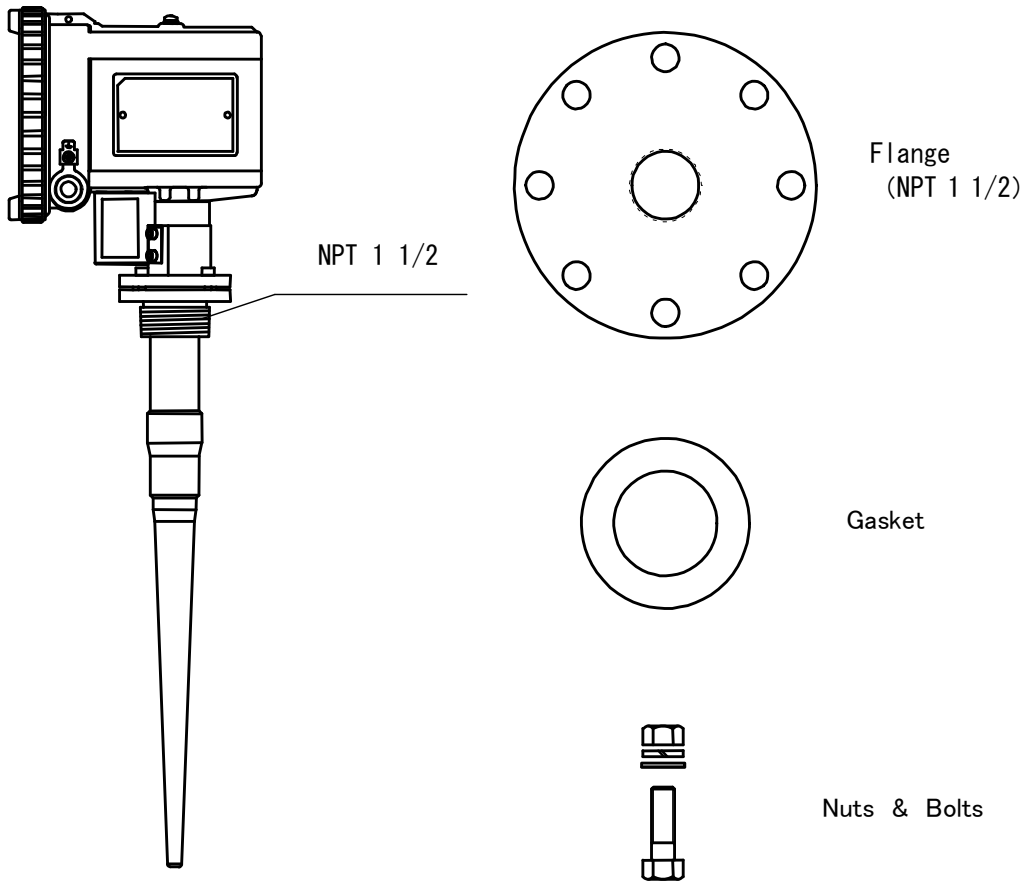

Fix rod antenna to flange

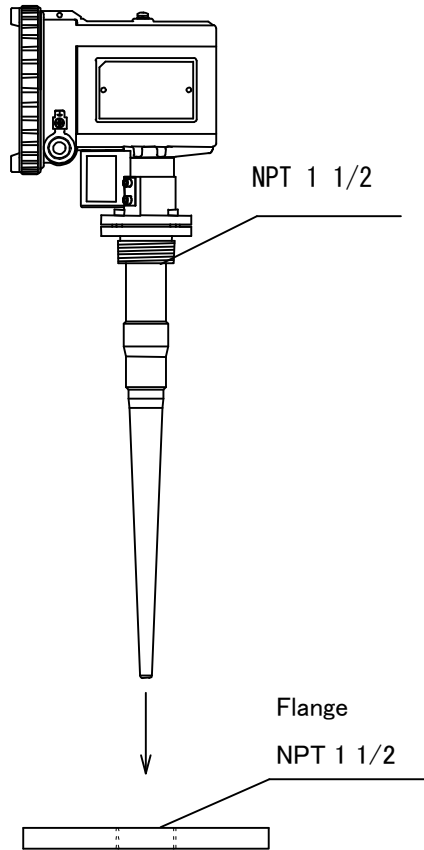

Place the gasket on the tank nozzle.
Carefully fit the flange and the cone antenna on the tank nozzle.
Tighten the assembly with the screws and nuts.

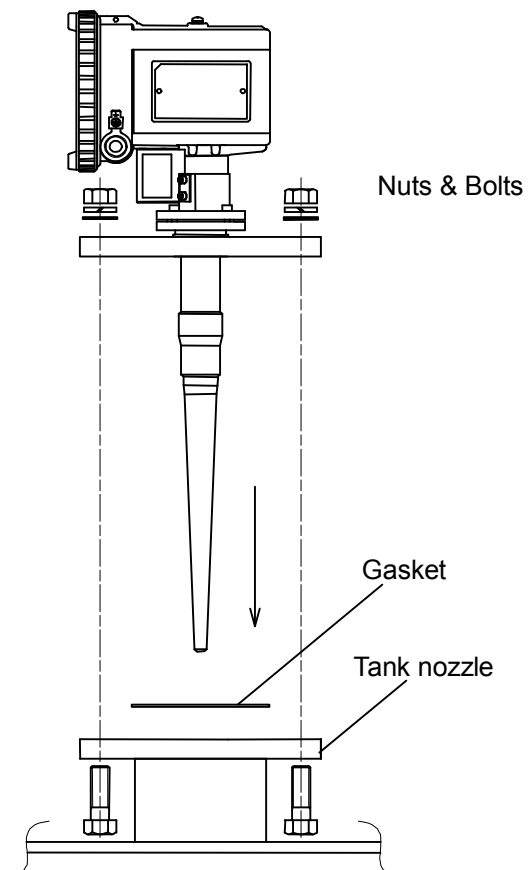

2.6 Installation Hints

Obstacles in the radar beam may generate signal reflections (false echoes) which may be larger than the reflected signals from the surface of the liquid. The MRG-10 may erroneously interpret such false echoes as reflections from the liquid surface. To reduce the influence of false echoes, attenuate such signals using the following methods.

1. Thin pipe or ladder

Microwave reflections from elongated metal objects such as thin pipes or ladders rungs are largest when the axis of such objects are in parallel with the electric field. The orientation of the electric field generated by the MRG-10 is as shown in the right figure.

Mount the MRG-10 so that the electric field is not in parallel with the axis of the obstacle which reduces the affect of the false echo emitted by it.

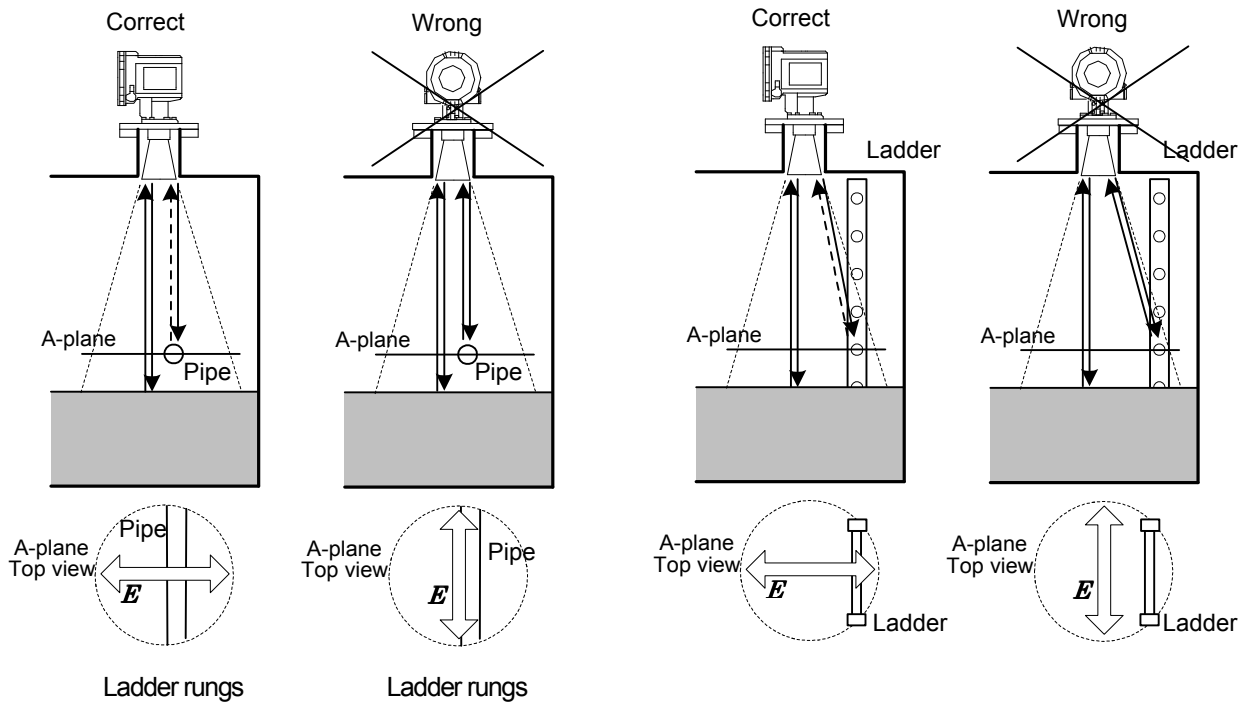
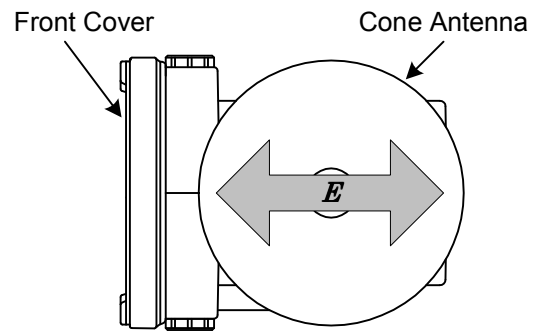

2. Shoulders and Struts

Install a reflector (flat metal plate) above the obstacle as shown in the figure.

	<p>Warning</p>
<p>Measuring range may be reduced if there are obstacles in the radar beam.</p>	

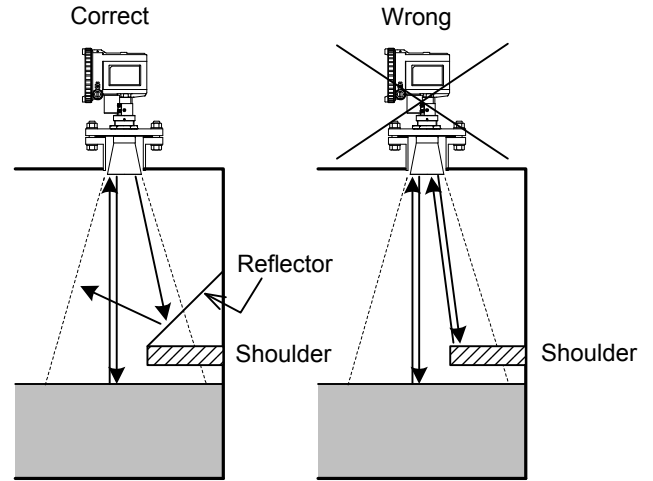

3. Center of the Tank

When the MRG is installed at the center of the tank, measurement may be adversely affected or become unstable because of microwave side-lobes (non-main beams). Thus center-of-tank installations should be avoided.

4. Narrow Channel

In case of channel applications, install the MRG so the axis of the electric field is at right angle to the channel wall to avoid influences from edge reflections off channel walls and the liquid surface.

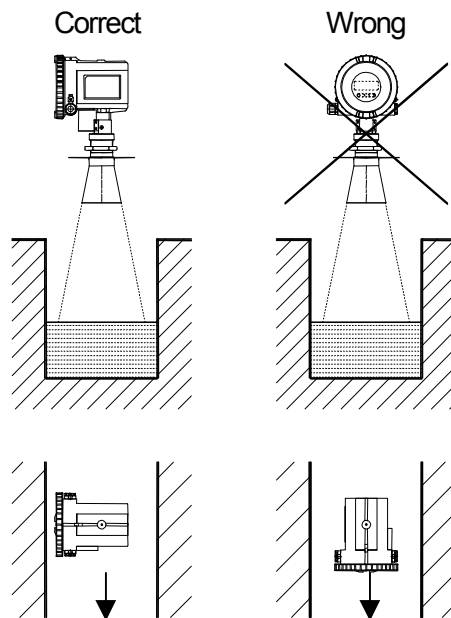

5. Tank Installation

For round tank applications, install the MRG so the axis of the electric field is oriented 45 degrees to the tank wall to avoid influences from edge reflections off channel walls and the liquid surface.

For flat wall tank applications, install the MRG so the axis of the electric field is perpendicular to the tank wall.

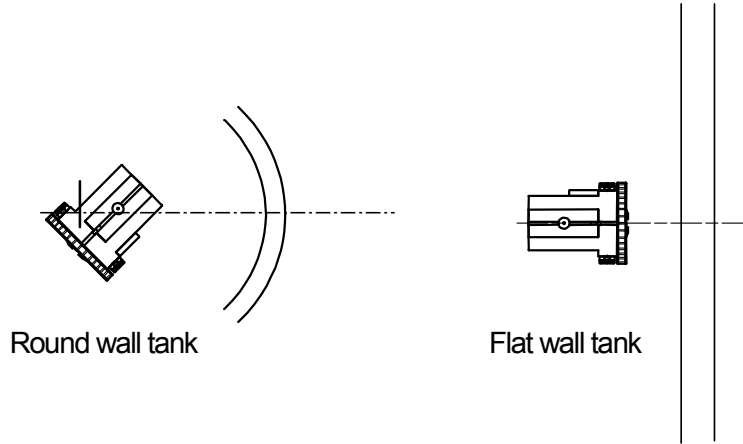

6. Open area Installation

This is an example of an open area installation.

In these types of applications, install the MRG so the axis of the microwave beam is perpendicular to the liquid surface.

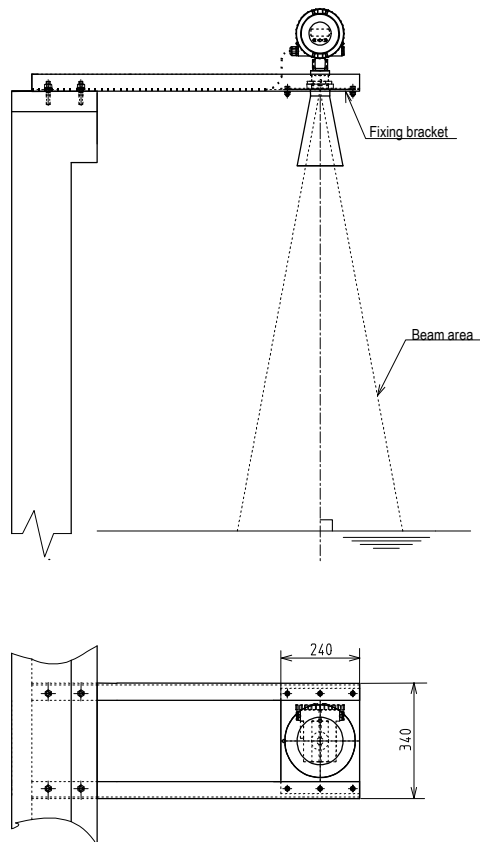

3 Electrical Installation

3.1 Connection of MRG-10



Caution

Handle the front cover with care as the glass panel and gasket are removable. The glass panel and gasket are fixed in place when the cover is screwed onto the case and tightened.

The gasket provides sealing between the housing and front cover and as such the front cover should be securely and firmly screwed onto the case.

1. Unscrew and remove the front cover.
2. Pass the cable through the entry and connect it to the terminal block.
3. Connect the shield to the ground terminal.
4. Replace the front cover and firmly screw it onto the case.

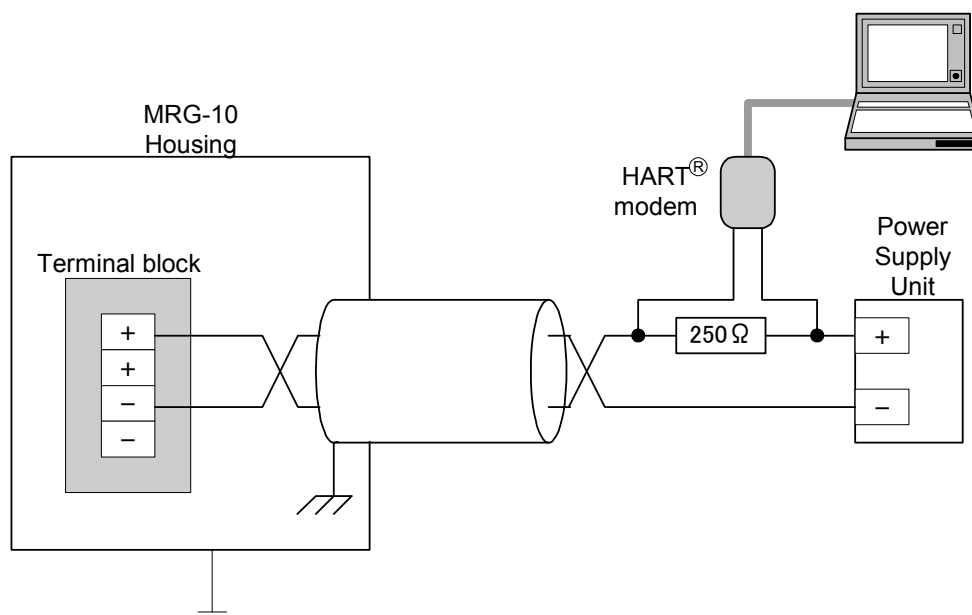
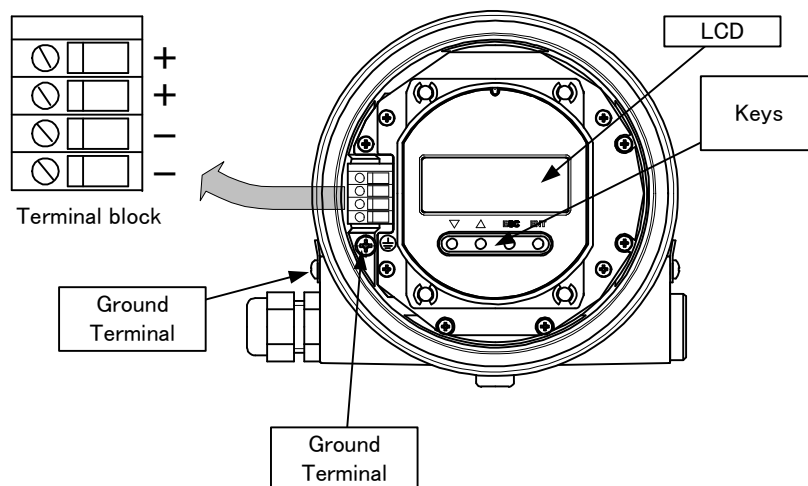

3.2 Cables

Cable	Use shielded twisted pair for connection. Cross-sectional area of conductor is 0.2 ...2.5mm ² . (AWG24 ...14)
Cable entry	2 × M20 × 1.5 (cable diameter 10mm max.)

3.3 Load

Minimum load for HART [®]	250 Ω
Maximum load (Non-Ex)	900 Ω
(EX)	540 Ω (TIIS / in preparation)

3.4 Power supply

Power (Non-Ex)	16...36VCD
(EX)	16...28VDC (TIIS / in preparation)

3.5 Grounding

The terminal must be connected to earth ground prior to connection to any other equipment.

3.6 Arrester replacement

Step 1; Loosen the 4 screws indicated by the arrows in the schematic below and remove the LCD panel.

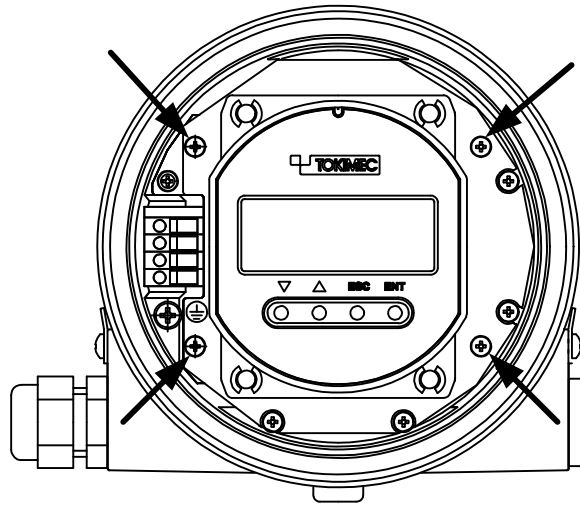

Step 2; Loosen the Arrester PWB fixing screw indicated by the arrow.

Step 3; Remove and replace the Arrester PWB.

Arrester PWB

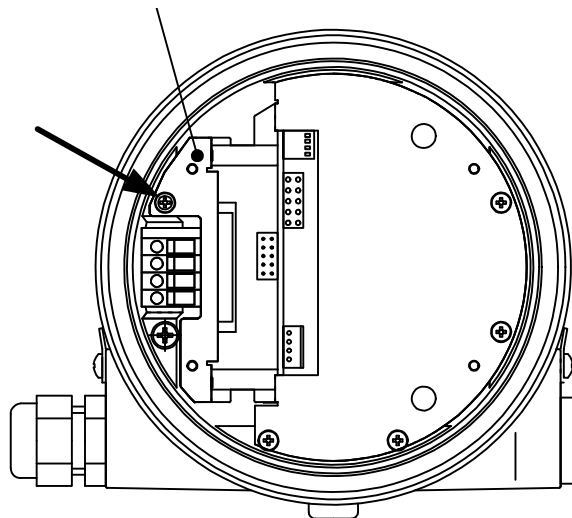

Step 4; Tighten the Arrester PWB fixing screw.

Step 5; Tighten the LCD panel fixing screw.
Please be sure that the LCD panel is positioned correctly.

4 Configuration method

It is a simple task to configure the MRG-10.
The MRG-10 can be configured with:

Display Panel & Key SW on MRG-10
PC (Setup Software)

4.1 Display Panel & Key SW

4.1.1 Display

Bar graph, measured data and units are displayed during normal operation. Blinking display of the last measured value indicates that gauge is in search mode.

When the key SW is used in configuration mode, the menu number or registered data is displayed.

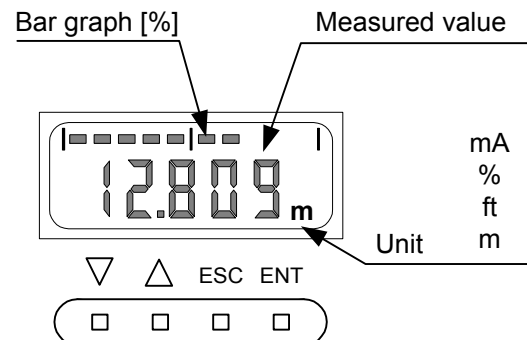

4.1.2 Key SW

1: ENT (Enter) key

Changes display from measurement mode to configuration mode.

Moves to the lower layer (from main menu to sub menu).

Moves the blinking cursor to the target column when changing the registered data.

Inputs data.

2: ESC (Escape) key

Changes display from configuration mode to measurement mode.

Moves to the upper layer (from sub menu to main menu).

Freezes changes to registered data.

3: △ (Up) key

Increases the main menu number and the sub menu number.

Increases the blinking column value.

4: ▽ (Down) key

Decreases the main menu number and the sub menu number.

Decreases the flashing column value.

4.1.3 Examples

Example-1

When R-constant is set to 6.275m from the default value.

Step	Key	Display	
1		7.956m	Measuring level(m) (Normal operation mode)
2	ENT	[1--]	Main menu number (Configuration mode)
3	ENT	[1-1]	
4	Δ	[1-2]	
5	Δ	[1-3]	
6	Δ	[1-4]	
7	ENT	10.000	Default value
8	ENT	10.00 0	"0" blinks
9	Δ × 5	10.00 5	× 5 : Push 5 times
10	ENT	10.0 05	
11	▽ × 3	10.0 75	
12	ENT	10. 075	
13	Δ × 2	10. 275	
14	ENT	10.275	
15	▽ × 4	16.275	
16	ENT	16.275	
17	▽	06.275	
18	ENT	06.275	
19	ESC	[1-4]	
20	ESC	[1--]	
21	ESC	4.231	Measuring level(m) (Normal operation mode)

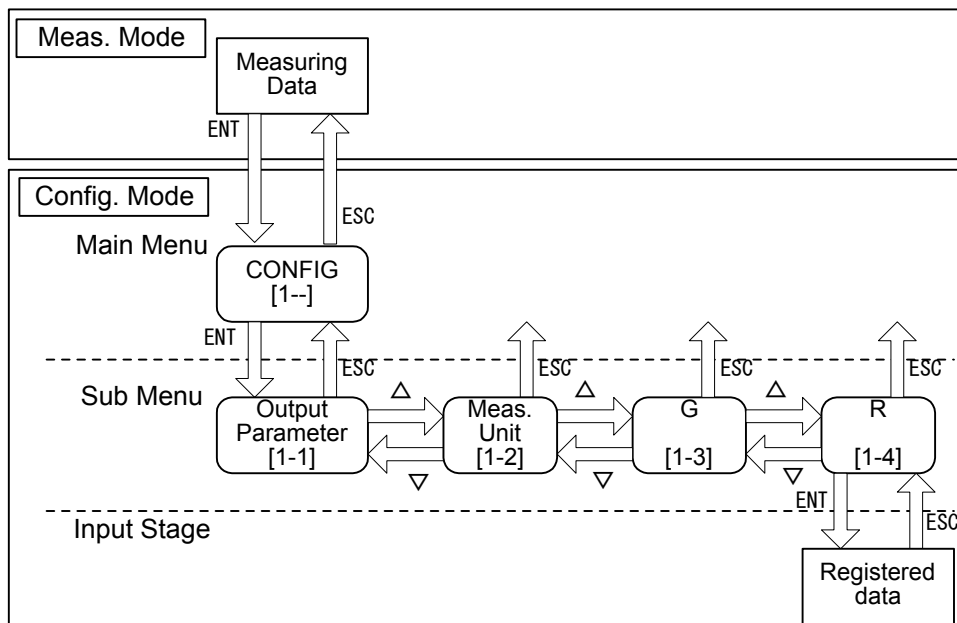

Example-2

When Volume point 2 is set to 2345.67m³.
Volume point can be set from 00000.00 to 99999.99.

Step	Key	Display	
1		4.231	Measuring level(m) (Normal operation mode)
2	ENT	[1--]	
3	Δ × 2	[3--]	Volume(Main menu)
4	ENT	[3-1]	
5	Δ × 3	[3-4]	Volume point(Sub menu)
6	ENT	[320]	Volume point 1
7	Δ	[321]	Volume point 2
8	ENT	000.00	Default value
9	ENT	000.0 0	"0" blinks
10	Δ × 7	000.0 7	× 7 : Push 7 times
11	ENT	000. 07	
12	▽ × 6	000. 67	
13	ENT	0000 0	
14	Δ × 5	0000 5	
15	ENT	000 05	
16	▽ × 4	000 45	
17	ENT	00 045	
18	▽ × 3	00 345	
19	ENT	00 345	
20	▽ × 2	02 345	
21	ENT	02435	
22	ENT	02435	
23	ESC	[321]	
24	ESC	[3-4]	
25	ESC	[3--]	
26	ESC	4.231	Measuring level(m) (Normal operation mode)

4.1.4 Parameter instructions

 - shaded areas indicate default settings.

[1--] CONFIGURATION Settings**[1-1] Output Parameter: LCD display**

Parameter	Value	Description
0	Level	Level value from target
1	Ullage	Distance between measuring reference point and target
2	Volume (%)	Volume rate value (%)
3	Current	Current value (mA) (4-20 mA)
4	Amplitude	Signal strength (dB)
5	Max. Volume	Max value of volume settings

When [ft] units are selected for "Level" or "Ullage" display, parameter range is calculated in 'feet'.

[1-2] Antenna type

Parameter	Value
0	4 inch cone
1	6 inch cone
2	8 inch cone
3	Rod antenna (inactive LONG)
4	Rod antenna (inactive SHORT)

[1-3] Measuring Unit

Parameter	Value	Description
0	m	Sets display in Metric units
1	ft	Sets display in Feet units

Note: When 'Measuring Unit' is changed, units of other parameters also change.

[1-4] G parameter (distance between flange reference point and measuring reference point)

Parameter	Default Value	Description
-3.000-3.000	0.000	$R+C-G \leq 20$ (Parameter range in metric [m] units)

If measurement unit is [ft], display will be converted to show 'feet' units.

[1-5] R parameter (Measurement range)

Parameter	Default Value	Description
0.000-23.000	0.000	$R+C-G \leq 20$ (Parameter range in metric [m] units)

If measurement unit is [ft], display will be converted to show 'feet' units.

[1-6] C parameter (Below measurement range)

Parameter	Default Value	Description
0.000-10.000	0.000	$R+C-G \leq 20$ (Parameter range in metric [m] units)

If measurement unit is [ft], display will be converted to show 'feet' units.

[1-7] H parameter (Deadband)

Parameter	Default Value	Description
0.000-23.000	0.103 (4 inch cone) 0.223 (6 inch cone) 0.343 (8 inch cone) 0.350 (Rod Long) 0.500 (Rod Short)	Parameter range in metric [m] units

If measurement unit is [ft], display will be converted to show 'feet' units

[1-8] Offset parameter for LCD level values

Parameter	Default Value	Description
-99.999-99.999	0.000	Parameter range, in metric [m] units

If measurement unit is [ft], display will be converted to show 'feet' units

Note: Offset affects LCD display only and does not affect analog output or other values.

[2--] ANALOG Settings

[2-1] Analog output parameter

Parameter	Value	Description
0	Level	Level value converted to 4-20 mA
1	Ullage	Ullage value converted to 4-20 mA
2	Volume	Volume value converted to 4-20 mA
3	Amplitude	Signal strength amplitude value converted to 4-20 mA

[2-2] Minimum output (4 mA)

Parameter	Output	Default Value	Description
-3.000-23.000	Level	0.000	Parameter range in metric [m] units
-3.000-23.000	Ullage	0.000	Parameter range in metric [m] units
0.000-100.000	Volume	0.000	[%]
0.000-100.000	Amplitude	0.000	[dB]

When [ft] units are selected for "Level" or "Ullage" display, parameter range is calculated in 'feet'.

[2-3] Maximum output (20 mA)

Parameter	Output	Default Value	Description
-3.000-23.000	Level	20.000	Parameter range in metric [m] units
-3.000-23.000	Ullage	20.000	Parameter range in metric [m] units
0.000-100.000	Volume	100.00	[%]
0.000-100.000	Amplitude	100.00	[dB]

When [ft] units are selected for "Level" or "Ullage" display, parameter range is calculated in 'feet'.

[2-4] Alarm selection

Parameter	Value	Description
0	High output	22 mA alarm output
1	Low output	3.9 mA alarm output
2	Hold output	Hold last value

[2-5] Fixed current output setting

Parameter	Value	Description
0	Measuring Value	[mA]
3.900-22.000	Fixed current	Any current value selectable

[3--] Volume Setting

[3-1] Linearization Selection

Parameter	Value	Description
0	Not Calculated	
1	Vertical Cylinder	
2	Spherical	
3	Horizontal Cylinder	
4	User Tank Table	

Tank Configurations

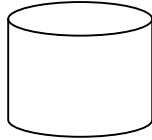

1: Vertical Cylinder

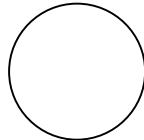

2: Spherical

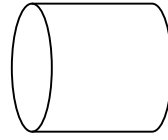

3: Horizontal Cylinder

[3-2] Linearization Point Number

Parameter	Default Value	Description
0-20	0	Input required no. of points for table

[3-3] Level point ([300] ~ [319])

Parameter	Default Value	Description
-3.000-23.000	0.000	Parameter range in metric [m] units

If measurement unit is [ft], display will be converted to show 'feet' units

[3-4] Volume point ([320] ~ [339])

Parameter	Default Value	Description
0-99999.99	0.000	

Display will be converted to the volumetric unit setting under [3-9].

If you create a volumetric table incorporating settings [3-2] ~ [3-4], you can produce a line chart such as that shown below which enables you to quickly calculate level and volumetric values.

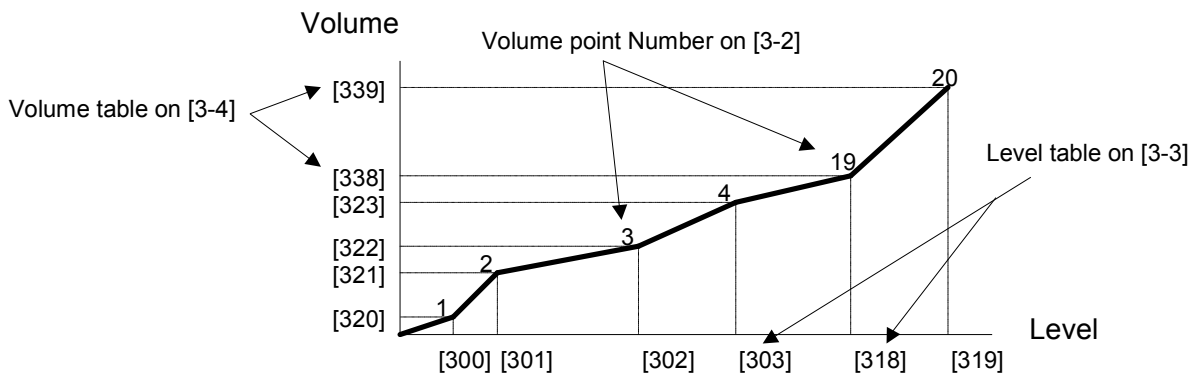

Level and Volume correlation on the user tank table

[3-5] Delete all tables

Parameter	Value	Description
0	Do not delete	
1	Delete all	Setting "1" clears table

[3-6] Diameter of the tank

Parameter	Default Value	Description
0.000-10.000	1.000	Parameter range in metric [m] units

If measurement unit is [ft], display will be converted to show 'feet' units.

[3-7] Length of the tank

Parameter	Default Value	Description
0.000-20.000	1.000	Parameter range in metric [m] units

If measurement unit is [ft], display will be converted to show 'feet' units.

[3-8] Offset level

Parameter	Default Value	Description
-3.000-23.000	0.000	Parameter range in metric [m] units

If measurement unit is [ft], display will be converted to show 'feet' units.

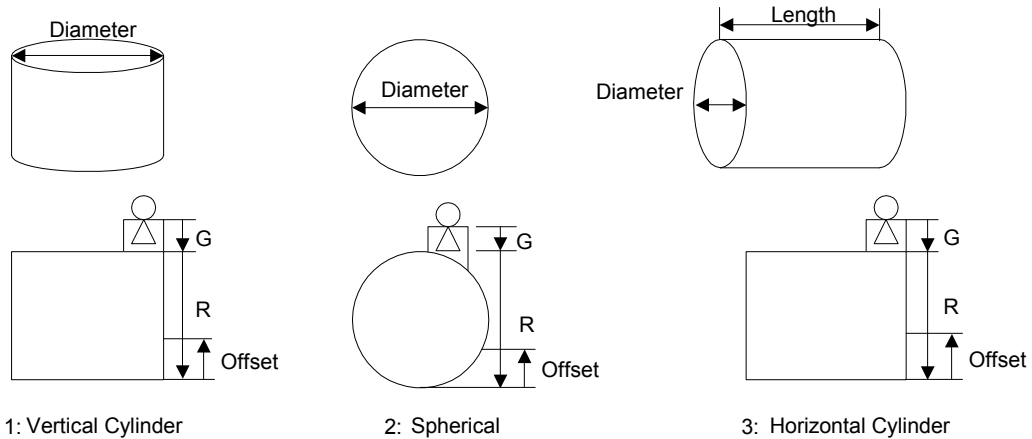

[3-9] Volume unit

Parameter	Value
0	m ³
1	Gallons
2	Barrels
3	Ft ³

[4--] Calibration

[4-1] 4mA Calibration

Parameter	Default Value	Description
3.50-4.50	4.00	In fixed current output mode with current set at 4mA, input ammeter reading.

[4-2] 20mA Calibration

Parameter	Default Value	Description
15.00-25.00	20.00	In fixed current output mode with current set at 20mA, input ammeter reading.

[4-3] Offset Calibration

Parameter	Default Value	Description
-1.00-1.00	0.00	Parameter range in metric [m] units

If measurement unit is [ft], display will be converted to show 'feet' units.

[4-4] Span Calibration

Parameter	Default Value	Description
0.90-1.10	1.00	

[5--] Advanced Setting

[5-1] Averaging Time

Parameter	Default Value	Description
1-120	10	Measuring value is averaged in accordance with [sec] setting

[5-2] Noise Margin

Parameter	Default Value	Description
0-100.00	3.00	Noise is eliminated in accordance with [dB] setting

When noise level is high, noise can be masked by attenuating the signal gain.

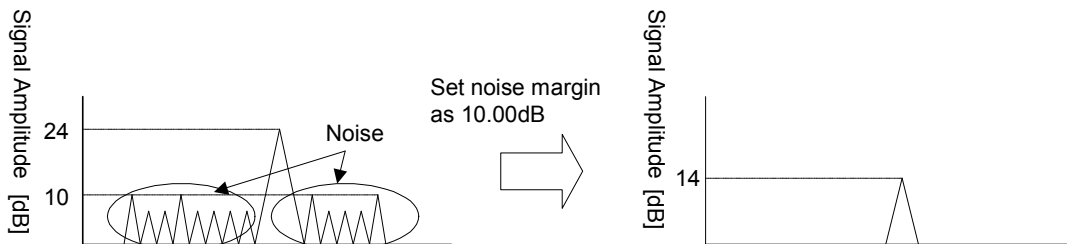

[5-3] Search Delay

Parameter	Default Value	Description
1-120	30	Time delay after loss of echo until restart in accordance with [sec] setting.

[5-4] Alarm Delay

Parameter	Default Value	Description
1-120	30	Time delay after loss of echo until alarm sounds in accordance with [sec] setting.

[5-5] Bottom Window

Parameter	Default Value	Description
0-0.5	0.3	Parameter range in metric [m] units

If measurement unit is [ft], display will be converted to show 'feet' units.
Valid only when [5-7] is set at "0".

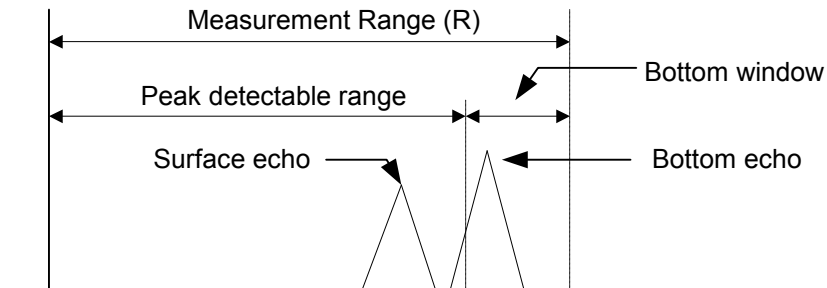

[5-6] First Echo Flag

Parameter	Value	Description
0	Max Echo	Max strength echo defined as surface echo
1	First Echo	First echo defined as surface echo

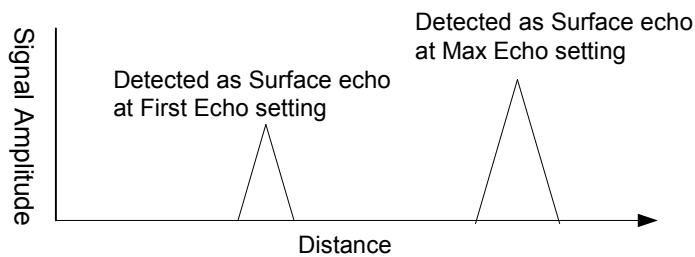

[5-7] Bottom Visible

Parameter	Value	Description
0	Bottom Visible	When tank bottom echo is larger than surface echo (such as with oil fluids). Effective against echo misdetection.
1	Bottom Invisible	When tank bottom echo is smaller than surface echo (such as with water). Setting "1", invalidates this function.

[6--] Noise

[6-1] Noise table number

Parameter	Default Value	Description
0-10	0	Input required no. of points for table

[6-2] Noise table ([600] ~ [609])

Parameter	Default Value	Description
0.000-20.000	0.000	Noise position by distance Parameter range in metric [m] units

If measurement unit is [ft], display will be converted to show 'feet' units.

[6-3] Amplitude threshold ([610] ~ [619])

Parameter	Default Value	Description
0-100.00	0.00	[dB]

If you create a noise table incorporating settings [6-1] ~ [6-3], you can produce a line chart such as that shown below which enables you to eliminate lower signal strength noises below the line.

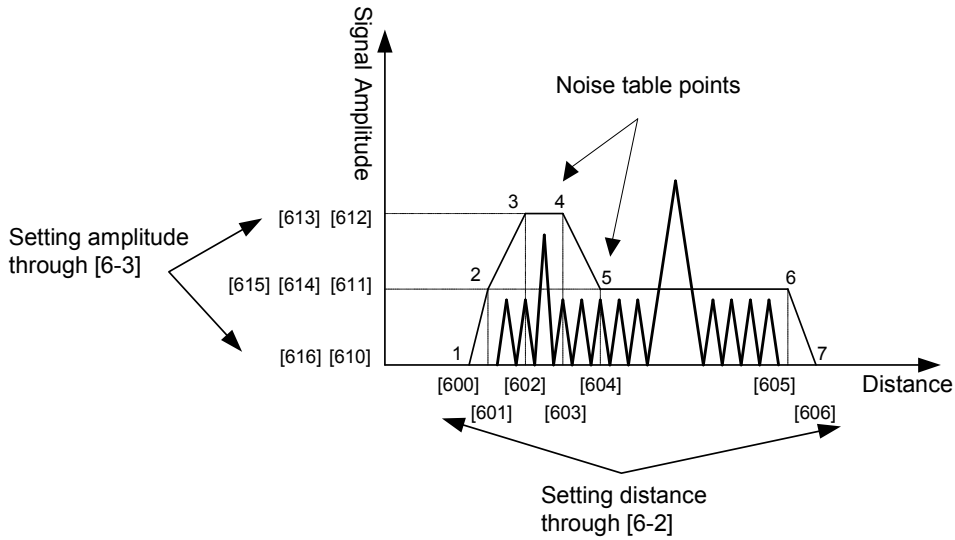

Amplitude at distance 0m and 20 m is set at 0 dB as default.

[6-4] Delete All

Parameter	Value	Description
0	Do not delete	
1	Delete All	Setting "1" clears noise table

[7--] Other[7-1] Password: **not normally used**

[7-2] Re-search

Parameter	Value	Description
0		
1	Research	Mandatory surface echo re-search

[7-2] User Reset

Parameter	Value	Description
0		
1	Initialization	Initialized by "1" setting

[7-3] Error Status

Indication	Error status
E-00	No error
E-01	Internal ROM Error
E-02	Internal RAM Error
E-03	Transmission error
E-04	Amplitude detection malfunction
E-05	Volume table error
E-99	Echo search status

[7-4] Software Version

[7-2] Hardware Reset

Parameter	Value	Description
0		
1	Reset	Setting "1" executes hardware reset

5 Configuration

5.1 Basic settings

Set up the following parameters

- Output Parameter Select measurement value displayed on the LCD.
- Meas. Unit Select measurement unit, meter or feet.
- Antenna Type Select type of antenna.
- R Set the distance from ref. point to level zero.
- C Set the distance from level zero to bottom of tank.
(‘C’ is normally set to ‘0’. If it is necessary to measure negative level, please set the distance.)

- H Set the distance from ref. point to measurement range.
(see 5.2.1)

Parameters of tank dimensions are optimized for your application.

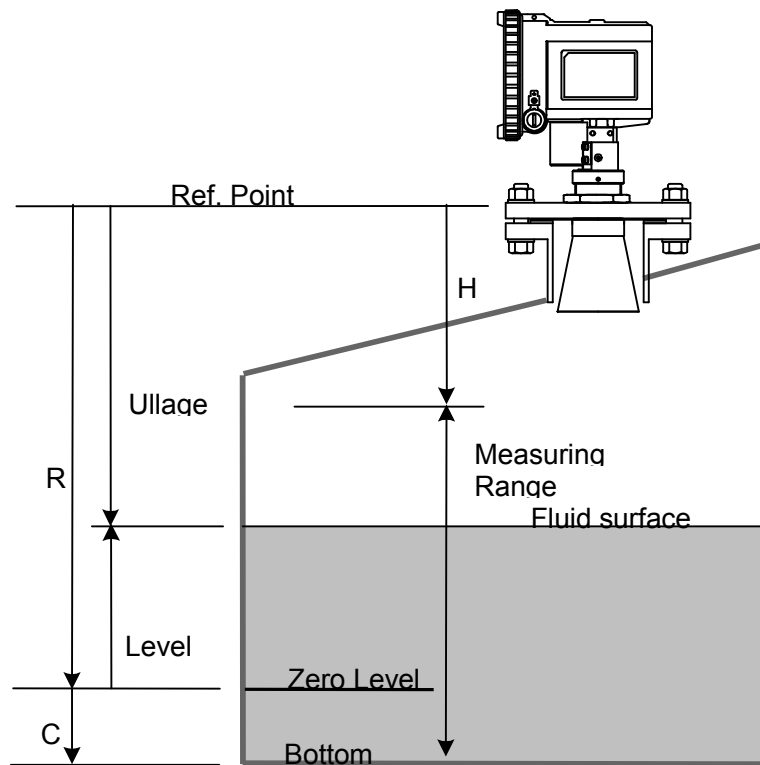

- Analog Output Parameter Select measurement value output for analog output.
- Minimum Output Set value corresponding to 4mA.
- Maximum Output Set value corresponding to 20mA.
- Alarm Selection Set value to be output when the gauge misses the echo.
Low(3.9mA), High(22mA) or Hold Last Value

Configuration with PC software

- PC connection
PC configuration software can also be used for commissioning.

1) Connect HART modem to both ends of resistor as shown below.

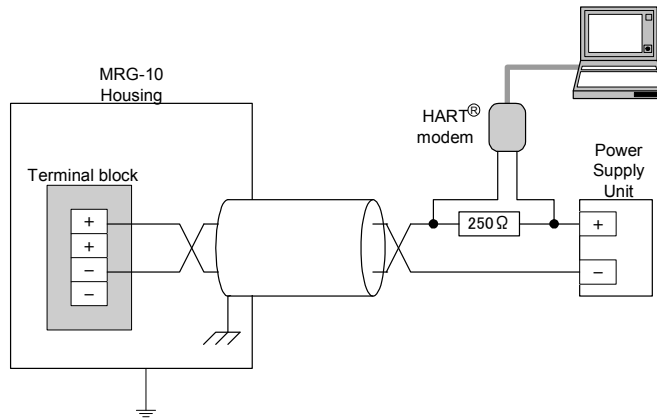

2) Open the software. Enter the HART modem port number and click the “set” button. When communication is completed successfully, ID, Version No and Product Name will appear in the boxes.

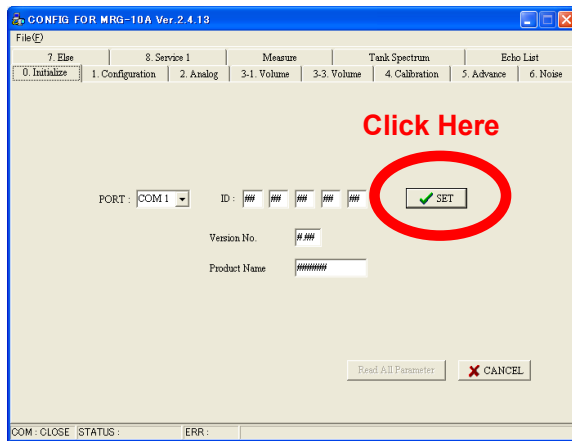

3) By selecting other tabs such as the sample below, you can set any parameter. Any action requires “READ” parameters from the main unit, before changing values (pressing the “ENTER” key may be required to set value changes) and clicking “WRITE” to the main unit.

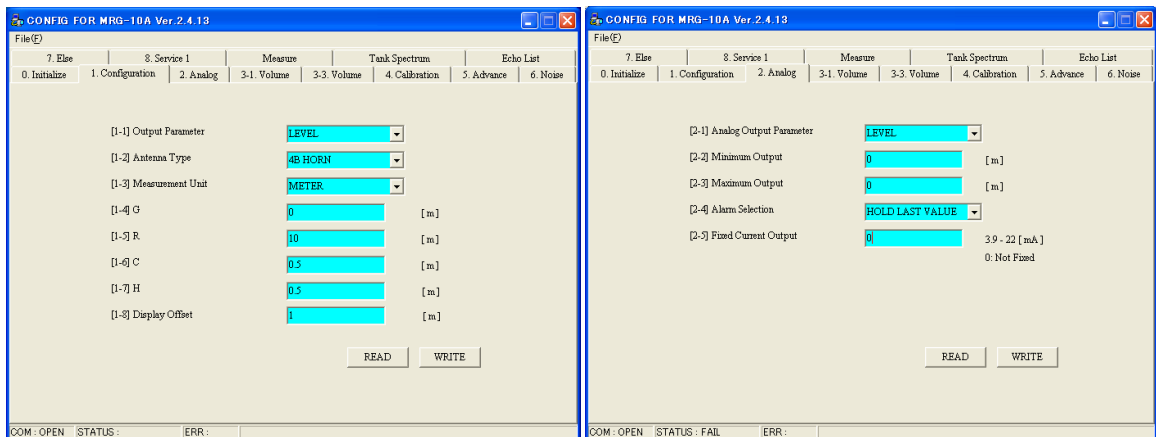

Configuration Setting Tab

Analog Setting Tab

5.2 Negative level point measurement

Value 'C' defines below zero level. When C values are set, the LCD or PC Hart communication will show negative values.

Note: If 4mA corresponds to LV 0m, Analog output will be maintained at 4mA even if measurement values fall below LV 0m.

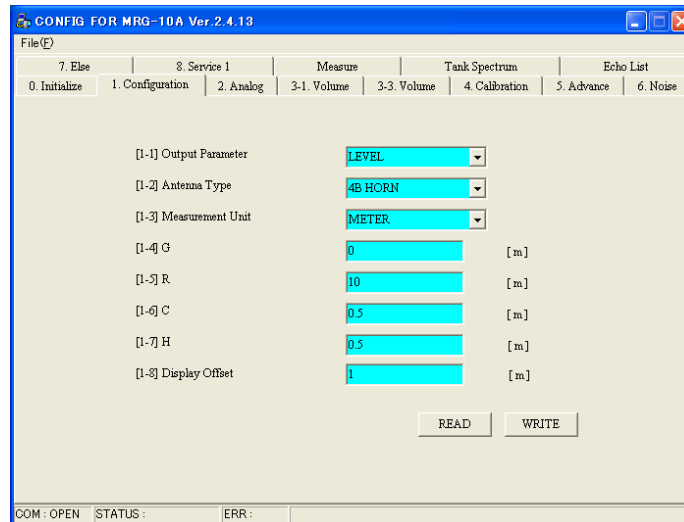

5.3 Avoiding disturbance echoes.

There are two ways to avoid the disturbance echo problem.

5.3.1 Dead Band (=“H”)

When there are disturbance echoes in the near zone such as stairs at the top of the tank, the gauge may capture and interpret these echoes as coming from the liquid surface.

Set up “H” to avoid this problem.

All echoes within this area would be outside of the measuring range and ignored.

5.3.2 Noise Table

If there are disturbance echoes in the effective measuring range and the gauge tracks such echoes, set up “Noise Table” parameters.

You can adjust the threshold level for sections of the measurement range with these parameters.

“Noise Table” parameters are comprised of ullage points and threshold values. Up to 10 points of values can be established respectively with linear interpolation between points. (Amplitude at distance 0m and 20 m is set at 0 dB as default.)

If disturbance echoes are tracked, you should first check the ullage and the amplitude level with the LCD display or with the configuration software.

To create a noise table, follow the steps below.

- 1) Enter Menu code [6-1], then set the noise table number (maximum 10 points).
- 2) Enter Menu code [6-2], and set distance parameters into the data field in accordance with selected numbers. (For example, if "10" is set at [6-1], you will need to set data [600]~[609] for distance values.)
- 3) Set distance data for [600], and push ENT to complete the entry. Similarly set distance values for [601]...[609].
- 4) After completing input of distance values, the next step is entering amplitude values.
- 5) Return to the sub-menu by clicking the ESC key. Then enter Menu code [6-3] and set threshold level parameters into the data fields in accordance with selected numbers. For example, if "10" is set at [6-1], you will need to set data [610]~[619] for amplitude values.)
- 6) Amplitude points must correlate to the distances defined under [6-2]. Select table address (ex. [610] and enter amplitude data, then click ENT to complete the entry. Similarly, set amplitude data for [611]...[619].
- 7) After setting all data, return to the Sub-Menu by clicking the ESC key of the LCD panel. When returning to the main menu, click ESC again. Click ESC again to go to the measurement mode.

Note: When using PC configuration software, enter all data into the following menu then click "WRITE".
 Setting of distance data must be in ascending order, that is, from shortest to longest distance. Noise table error and noise table malfunction will occur if settings are mis-ordered. Error status will appear under [7-3]

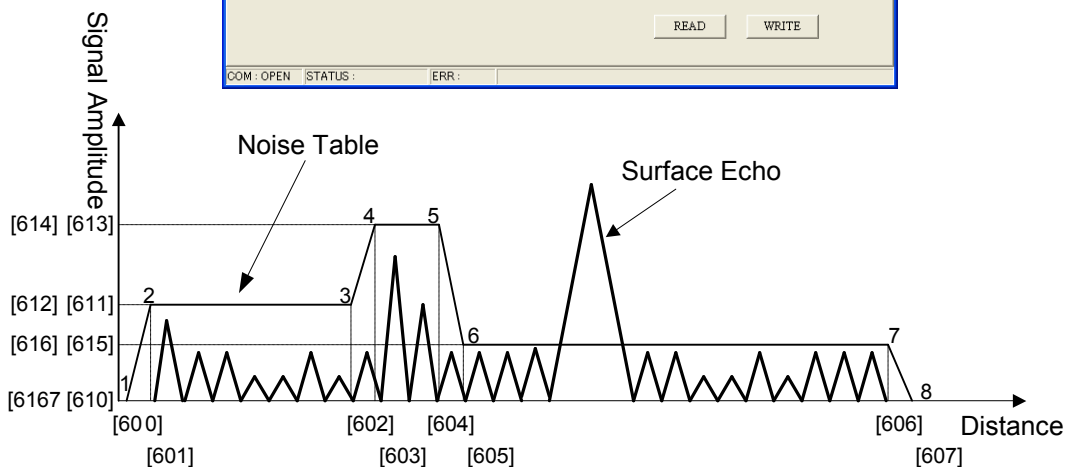
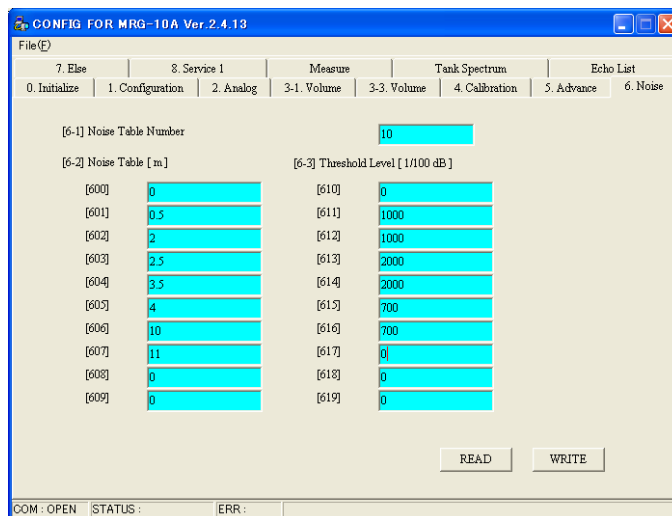

Example of a noise table is shown above. All noise lower than the noise threshold line will be ignored.

5.3.3 One point advice regarding noise table input procedure

It is necessary to provide some allowance around the echo peak and a margin of threshold for noise amplitude. These are $\pm 0.3\text{m}$ and $+5\text{dB}$ respectively.

Noise Table point “n” must also be nearer than next Noise Table point “n+1”. If this rule is not maintained, noise table errors will occur and this function will become invalid.

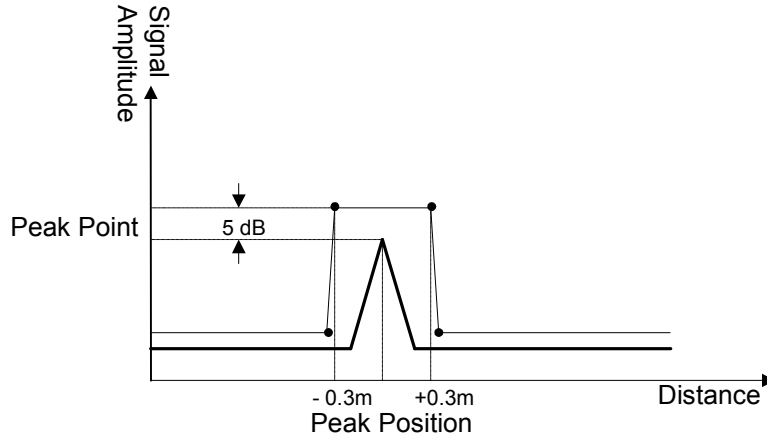

Also by using the PC configuration software, you can add or change the position of the noise table with a right click.

- 1) On the “Tank Spectrum” tab, when the “START” button is clicked, you may view the red line wave form data from the main unit as shown below.
- 2) If you would like to set the noise table manually, right click and select “ADD” at designated points for the new table. Also the table (points) can be moved by a left-click and dragging.
- 3) After the noise table is set, click the “Noise Write” button to complete.

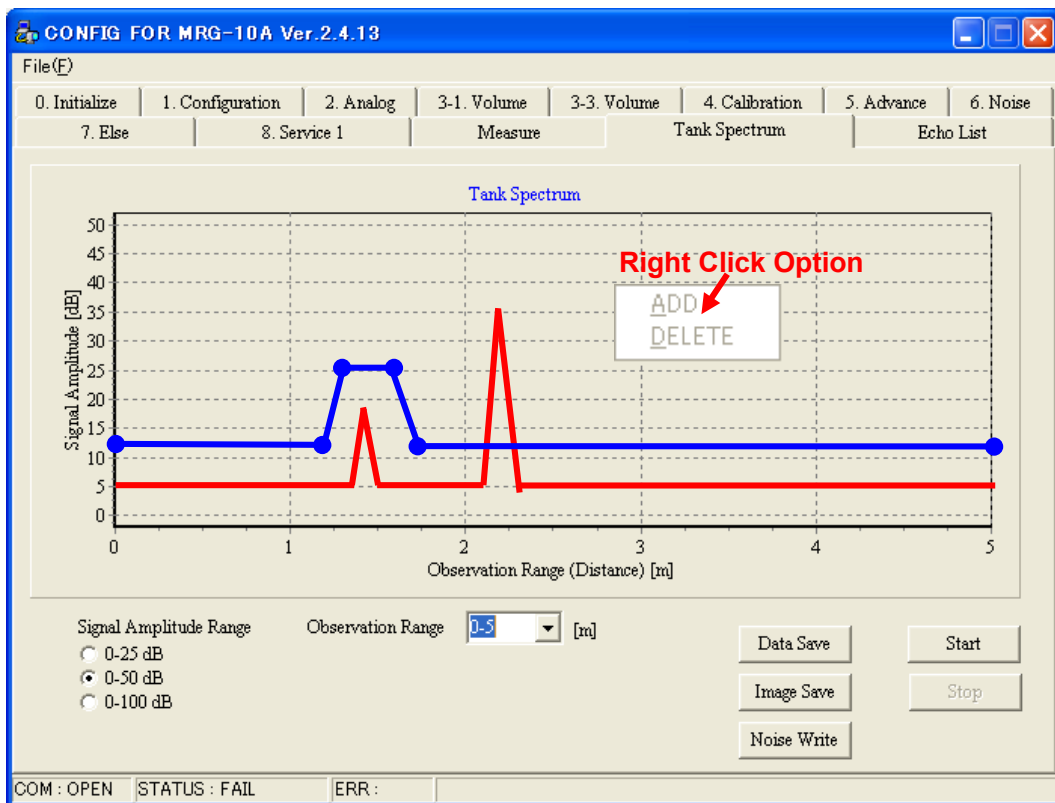

5.3.4 Noise Margin

When noise level is high over the whole range, the threshold level over the entire range can be set by the “noise margin” parameter as shown below.

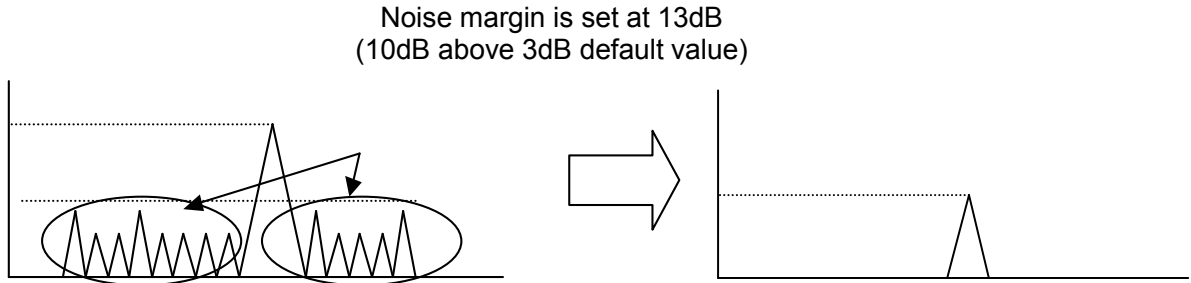

From the LCD menu, select [5-2].

With the PC configuration software, please refer to [5-2] under the “5. Advance” tab.

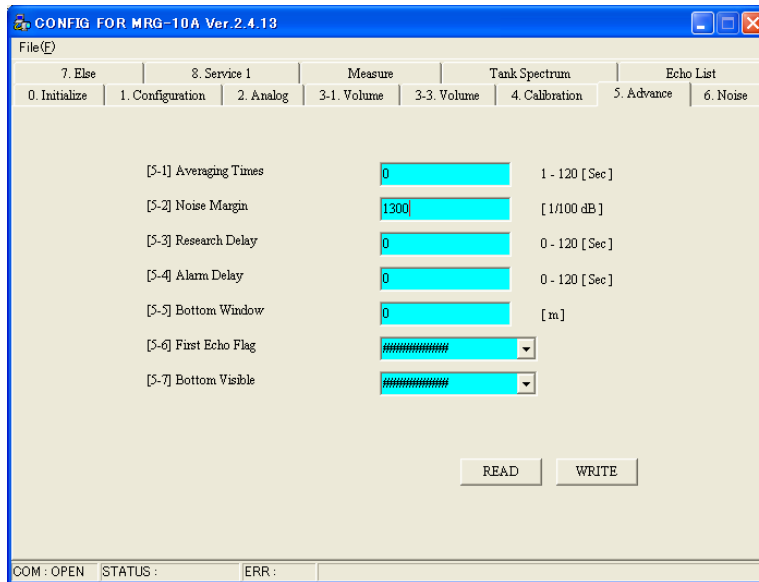

5.4 Volume calculation

There are 4 types of volume calculations which are set up by the Linearization Selection parameter.

- Spherical Tank

Volume is calculated from diameter, offset level and measured level. Diameter is the diameter of the sphere and offset level is the measurement level compensation factor.

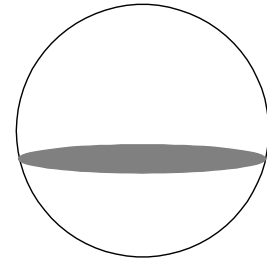

- Vertical Cylinder Tank

Volume is calculated from diameter, offset level and measured level. Diameter is the diameter of the tank and offset level is the measurement level compensation factor.

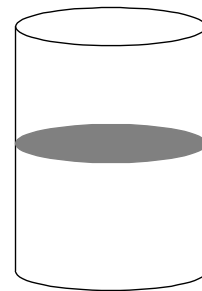

- Horizontal Cylinder Tank

Volume is calculated from diameter, length, offset level and measured level. Diameter is the diameter of the tank and offset level is the measurement level compensation factor. Length is the horizontal length of tank as shown.

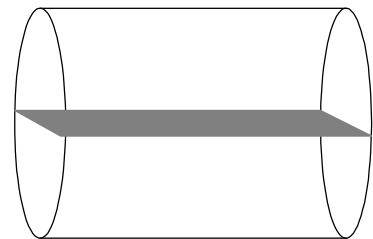

- Tank Table

Set up Linearization Point Number.

It is possible to set up 20 points each for level and volume respectively in the Tank Table which are linearly interpolated between points.

More than two points must be input to set up the Tank Table. (Tank Table Error)

Four volume units can be selected - cubic meter, gallons, barrels and cubic feet.

To create the volume table, follow the steps below.

- 1) Select "4" for menu code [3-1].
- 2) Set the required number of point settings for menu code [3-2]. (Max 20 points.)
- 3) Enter menu code [3-3]. Select point and set level parameters into the data field in accordance with the selected numbers. (e.g. when setting 20 points at [3-2], [300]~[319] can be set.)
- 4) Input Level data then click ENT to enter values for [300] ~ [319].
- 5) After completing input of Level data, the next step is entering the Volume data.
- 6) Return to the sub-menu by clicking the ESC key. Then enter Menu code [3-3], and set the volume parameters into the data fields in accordance with the selected numbers. (e.g. when setting 20 points" at [3-2], [320]~[329] can be set.)

- 7) Volume point must correlate to the level data defined under [3-2]. Select table address (ex. [320]), enter amplitude data and click ENT to complete entry. Similarly, enter data for [321]...[329].
- 8) After setting all data, return to the Sub-Menu by clicking the ESC key on the LCD panel. To return to the main menu, click ESC again. Click ESC once more to go to the measurement mode.

Note: When using PC configuration software, enter all data in the following menu then click "WRITE".

Setting of distance data must be in ascending order, that is, from shortest to longest distance. Volume table error and volume table malfunction will occur if settings are mis-ordered. Error status will appear under [7-3]

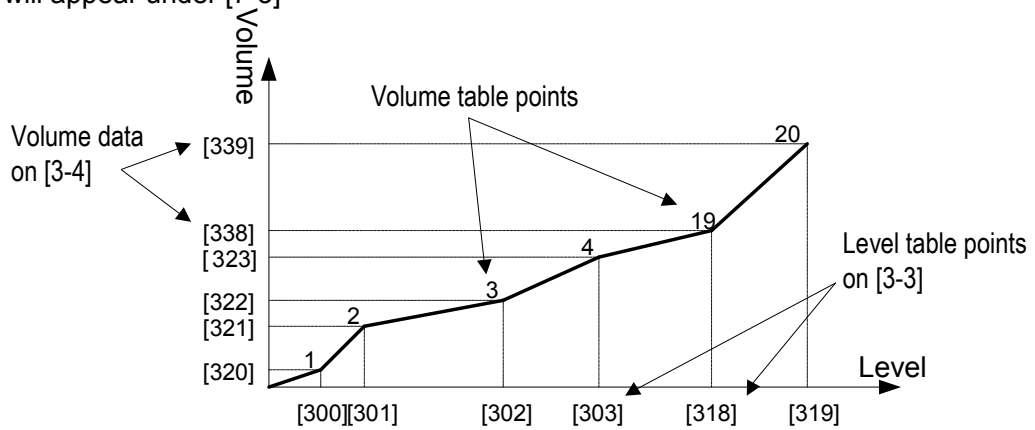

CONFIG FOR MRG-10A Ver.2.4.13

File(E)

7. Else	8. Service 1	Measure	Tank Spectrum	Echo List
0. Initialize	1. Configuration	2. Analog	3-1. Volume	3-3. Volume
			4. Calibration	5. Advance
				6. Noise

[3-3] Level Point			[3-4] Volume Point		
[300]	0.5	[310]	4.2	[320]	10
[301]	1	[311]	4.3	[321]	30
[302]	3	[312]	4.4	[322]	40
[303]	3.5	[313]	4.5	[323]	60
[304]	3.6	[314]	4.6	[324]	61
[305]	3.7	[315]	4.7	[325]	62
[306]	3.8	[316]	4.8	[326]	63
[307]	3.9	[317]	4.9	[327]	64
[308]	4.0	[318]	5	[328]	65
[309]	4.1	[319]	6.5	[329]	66
				[330]	67
				[331]	68
				[332]	69
				[333]	70
				[334]	71
				[335]	72
				[336]	73
				[337]	74
				[338]	75
				[339]	130

READ WRITE

COM: OPEN STATUS: ERR:

5.5 Analog value compensation

When analog output current is not correct, revise the value in the following manner.

Input "4.000mA" under "Fixed Current Output" [2-5], then input the measured current value under "4mA Calibration" [4-1].

Input "20.000mA" under "Fixed Current Output" [2-5], then input the measured current value under "20mA Calibration" [4-2].

5.6 Measuring value compensation

Offset level from reference point and scale factor are adjusted under [4-3] (offset) and [4-4] (scale factor). If there is a difference between the Tank ref. point and the MRG-10 ref. point, you can input "G" for calibration [1-4].

5.7 Bottom recognition

Tank bottom recognition is necessary for measurement of low reflection targets such as oil surfaces. In such cases, the smaller amplitude echo from liquid surface reflections is concealed in the larger echo from the tank bottom and the gauge can not distinguish the surface reflection echo from the bottom echo. "Bottom Visible Flag" and "Bottom Window" parameters of the gauge function to avoid the tracking of bottom echoes. Initial settings of these parameters are "On" and "0.3m".

The gauge outputs level value as the bottom level, when the surface echo is in the bottom window. However when the level is higher and the surface echo is not in the bottom window, the gauge can distinguish surface echoes from bottom echoes. On the other hand, if bottom echoes cannot be discerned in high reflection targets such as water, the "Bottom Visible Flag" parameter should be set at "Off" to eliminate any bottom deadband.

5.8 Other

5.8.1 Echo search methods

Two echo search methods are available - one based on recognizing the echo of maximum signal strength (Max. Echo Flag) and the other where the first echo in the measurement range is captured (First Echo Flag).

The "First Echo Flag" provides a means to recognize the surface echo from other echoes in the measuring range.

5.8.2 Reset

Initializes all setting values.

5.9 Pipe antenna setting

5.9.1 Overview

The following instructions are applicable when the MRG-10 is used in the pipe mode (hence referred to as "pipe antenna").

Advantages and disadvantages of the pipe antenna are as follows.

1) Advantages

Existing pipe can be used as the pipe antenna.

Even if obstacles are located near to the beam area, measurement will not be affected.

Measuring coverage can be extended ~~for~~ to low dielectric constant liquids.

2) Disadvantages

Material of the pipe (metal, etc.) must be that which can contain and channel microwaves.

Dirty, dusty conditions inside of the pipe may cause noise disturbance echoes which decrease accuracy.

5.9.2 Pipe antenna specifications

Specifications	
Antenna size	4B Cone antenna
Measurable Range	10 m
Accuracy	± 10 mm (< 5 m) ± 20 mm (< 10 m)
Pipe specification (metal pipe only)	ID over 100mm
Max hole for air vent (per 1 m)	φ 5 mm / 2pcs

5.9.3 Parameter setting

5.9.3.1 Antenna Type (Menu code:[1-1])

Use actual antenna type. (ex. 4inch cone antenna)

5.9.3.2 Span calibration

- As the speed of microwaves propagated inside of pipes differ from the speed of microwaves when propagated in free spaces, a compensating coefficient must be input in the “Span Calibration” parameter (Menu code, [4-4]).
- “Span Calibration” values are derived from the inner diameter of the pipe. The following table is one example.

Inner Pipe Dia [mm]	Span Calibration
107	0.9507

- When span calibration value ('F') is unknown, 'F' can be calculated from two points - reference level value (X) and measured level value (Y) - using the following equation.

$$F = (Y_{\text{High}} - Y_{\text{Low}}) / (X_{\text{High}} - X_{\text{Low}})$$

F : Span calibration value
 X_{High}: High reference level value
 X_{Low} : Low reference level value
 Y_{High}: High measured level value
 Y_{Low}: Low measured level value

5.9.3.3 Offset compensation

- Offset setting may be required using Menu code: [4-3].
- Offset value is derived from the difference in measured level and reference level at 1 point.

5.9.4 Considerations

- Pipe material should be metal.
 In cases of existing pipes of concrete or PVC material instead of metal, span calibration may not be required as their low dielectric constants allow transmission of microwaves. However when wet, such pipe materials exhibit high reflectivity characteristics from wetted surfaces. This affects accuracy and span calibration becomes necessary. Because of such changes in characteristics under wet conditions, non-metal pipe applications are not recommended.
- Air vents (10mm dia.) for pressure release should be incorporated and located above the tip of the antenna.

5.10 Key Parameter List

Title	Menu Code	Parameters	Sub Menu Code	Sub Parameter	Lowest Menu Code	Input Value
CONFIGURATION	[1--]	Output Parameter	[1-1]			0: Level 1: Ullage 2: Volume(%) 3: Current 4: Amplitude 5: Max. Volume
		Antenna Type	[1-2]			0: 4inch Horn Antenna 1: 6inch Horn Antenna 2: 8inch Horn Antenna 3: Rod Antenna Short 4: Rod Antenna Long
		Meas. Unit	[1-3]			0: meter 1: feet
		G	[1-4]			-3 to +3m, (R+C-G) <=20m
		R	[1-5]			-3 to +23m, (R+C-G) <=20m
		C	[1-6]			0 to +3m, (R+C-G) <=20m
		H	[1-7]			0 to +23m
		Offset of level value on LCD	[1-8]			-99.999 ~ 99.999 m
ANALOG	[2--]	Analog Output Parameter	[2-1]			0: Level 1: Ullage 2: Volume(%) 3: Amplitude(dB)
		Minimum Output	[2-2]			-3 to +23m (level, Ullage) 0 to 100 (Vol., Amp.)
		Maximum Output	[2-3]			-3 to +23m (level, Ullage) 0 to 100 (Vol., Amp.)
		Alarm Selection	[2-4]			0: High(22mA) 1: Low(3.9mA) 2: Hold last value

Title	Menu Code	Parameters	Sub Menu Code	Sub Parameter	Lowest Menu Code	Input Value
VOLUME	[3--]	Linearisation Selection	[3-1]			0: Not Calculate 1: Horizontal Cylinder 2: Spherical 3: Vertical Cylinder 4: User Tank Table
		Linearisation Point Number	[3-2]			2 to 20
		Input	[3-3]	Level Point	[300]~[319]	-3 to +23m
			[3-4]	Volume Point	[320]~[339]	0 to 99999.99
		Delete All	[3-5]			Execute by 1
		Diameter	[3-6]			0 to +10m
		Length	[3-7]			0 to +20m
		Offset Level	[3-8]			-3 to +23m
		Volume Unit	[3-9]			0: m3 1: gallons 2: barrels 3: ft3
CALIBRATION	[4--]	4mA Calibration	[4-1]			3.9 to 22mA
		20mA Calibration	[4-2]			3.9 to 22mA
		Offset Calibration	[4-3]			-1 to 1m
		Span Calibration	[4-4]			0.9 to 1.1
ADVANCE	[5--]	Averaging Times	[5-1]			1 to 120sec
		Noise Margin	[5-2]			0 ~ 100.00 dB
		Research Delay	[5-3]			1 to 120sec
		Alarm Delay	[5-4]			1 to 120sec
		Bottom Window	[5-5]			0 to 0.5m
		First Echo Flag	[5-6]			0: Max echo 1: First echo
		Bottom Visible	[5-7]			0: Bottom Visible 1: Bottom invisible
NOISE	[6--]	Noise Table Number	[6-1]			0 to 10
		Input	[6-2]	Noise Table	[600]~[609]	-3 to +23m
			[6-3]	Amplitude Threshold	[610]~[619]	0 to 100.00dB
		Delete All	[6-4]			Execute by "1"
ELSE	[7--]	Password	[7-1]			to service mode
		Re-Search	[7-2]			
		User Reset	[7-3]			Execute by 1
		Error Status	[7-4]			
		Software Revision	[7-5]			

6 Technical Information

System

Operating frequency	• 5.8 GHz
Half-power beam width	• 4 " Cone antenna: 34 deg • 6 " Cone antenna: 22 deg • 8 " Cone antenna: 17 deg • Rod antenna : 30 deg
Measuring range	Max. 20 m (65 ')
Serial communication	HART communication
Key switch	4 keys for configuration
Display	5-digit LCD and bar graph

Power

Supply voltage	16..28 VDC(Ex) / 16..36 VDC(Non-Ex)
Specification for HART	• Ripple: 47..125 Hz • Vpp=200 mV (measured at 500 ohms) • Max. noise: 500 Hz..10 kHz • Vrms=2.2 mV (measured at 500 ohms)

Output

Variable	Ullage / Level / Volume / Current / Signal amplitude/Volume Max
Unit	Level, Ullage : m/ft Volume : % Current : mA Amplitude : dB
Signal type	Analog 4..20 mA, HART
Resolution	• Analog: 4 mA • Digital: 1 mm (0.04")
Update time	1 s

Averaging time	1..120 s
Signal on alarm	Hold/Low(3.9mA)/High(22 mA)
Load	Minimum load for HART communication 250 ohms.

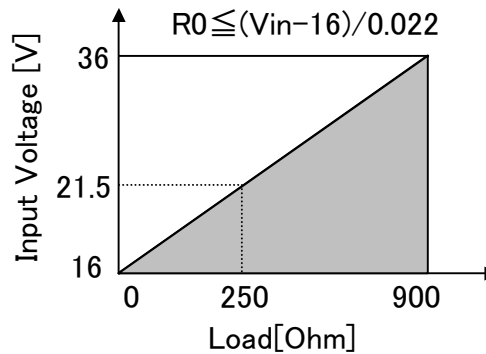

Accuracy

Measured error *)	±10 mm (0.4")
Linearity *)	±10 mm (0.4")
Repeatability *)	±1 mm (0.4")
Ambient temperature effect	±0.01% / 10 K

*) : Free-space reflection from flat metal surface, ambient temperature 25 °C (77 °F), atmospheric pressure.

Environment resistance

Ambient temperature	-20..70 °C (-40..158 °F)
Storage temperature	-40..80 °C (-40..176 °F)
Tank temperature	-20..150 °C (-4..302 °F)
Tank pressure	-0.1..1.0 MPa (-14..145 Psi)
Degree of protection	IP65
EU directive compliance	CE mark / EMC 89/336/EEC / EN 61326-1(2006)/ EN 61326-1(1997)+A1(1998)+A2(2001)+A3(2003)
Harmonized standard	EN 61000-4-2 (1995)+A1(1998)+A2(2001) EN 61000-4-3(2006)

	EN 61000-4-4(2004)
	EN 61000-4-5 (1995)+A1(2001)
	EN 61000-4-6 (1996)+A1(2001)
	EN 61000-4-8(1993)+A1(2001)
Vibration resistance	IEC 68-2-6 /1G
Cable Connection	
Cable type	Shielded twisted pair Cross-section area of cable: 0.2..2.5 mm ² , (AWG24..14)
Cable entry	2-M20X1.5, NPT 1/2" (cable dia. 6.5..9 mm)
Ground cable	Max. 4 mm ²
Material	
Transmitter Case	Aluminum
Cone antenna	316L stainless steel
Rod antenna	PFA (Thread part: 316 stainless steel)
Sealing parts	PTFE, Viton O-ring
Certificate and Approvals	
Hazardous area certification	Ex ia IIC T4 (TIIS)

7 Troubleshooting

<u>SYMPTOM</u>	<u>ACTION</u>
No level reading	Check the power supply.
Incorrect level reading	Check the gauge calibration. Check that gauge has not locked on an interfering object. Check for correct mechanical installation.
Serial Communication failure	Check the COM port setting in the LR setup program. Check the serial communication address. Check the cable and HART modem connections and make sure that correct cable and resistor are used.
Display Panel window is blank	Check the power supply.

Check the status of the gauge in the LCD display.
Status descriptions are as follows.

[E00]	Normal Operation	-
[E01]	Internal Error	Critical Error. Please contact service
[E02]	Memory Error	Critical Error. Please contact service
[E03]	Receive Error	No measured data. Please contact service
[E04]	Tank Table Error	Incorrect setting on tank table. Set up correctly.
[E05]	Noise Table Error	Incorrect setting on noise table. Set up correctly.
[E99]	Searching Echo	Conducting echo search.

TOKIMEC INC.

Control Division 1

2-16-46, Minami-kamata, Ohta-ku, Tokyo 144-8551 Japan

TEL: +81 3 3737 8621

FAX: +81 3 3737 8665