

Help protect mechanical equipment
From damage with the Vibration Switch

Vibration Switch

MODEL 66

OVERVIEW

The Vibration Switch is a safety device, which quickly detects abnormalities in mechanical equipment in order to help prevent breakdown. It is designed in accordance with Japanese explosion-proof standard (66EJ) to enable users to employ it in places where there is a risk of explosion. The reliable performance of the Vibration Switch is time proven - it has received very favorable user response from the time it was first marketed over 30 years ago.

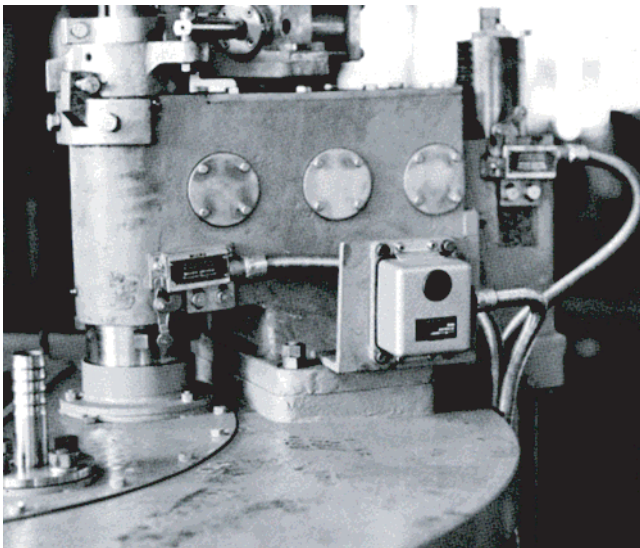

DETECTOR

Detectors used with the Vibration Switch are installed directly on the pump, motor and fan of the piece of equipment to be monitored in order to detect abnormal vibration due to a mechanical failure of these units in terms of acceleration.

Generally, if a breakdown occurs in mechanical equipment driven by an electric motor or internal combustion engine, such phenomena as temperature rise, increased noise and excessive current will occur. In addition, "Abnormal Vibration" always occurs along with these phenomena.

This abnormal vibration consists of 2 elements; abnormal frequency (number of vibrations per second) and abnormal amplitude.

Consequently, when safeguarding a piece of equipment by the method of detecting abnormal vibration, it is not sufficient to detect only one of these elements.

For example, if the amplitude of the vibration is measured using an amplitude meter, it will not be possible to detect a frequency abnormality. Also an abnormal amplitude resulting from eccentricity of a piece of rotating machinery will not show up in the vibration frequency.

A Vibration Switch detector detects abnormal vibration by means of acceleration, which is common to both amplitude and frequency.

Construction of DETECTOR

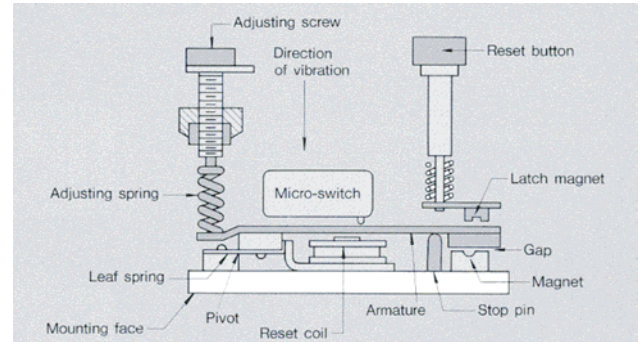

If the detector is subjected to vibration acceleration in the "Direction of vibration", a moment will be set up around the spring joint of the armature, tending to separate the armature from magnet below it. Similarly, the adjusting spring will also generate a moment around the spring joint, tending to separate the armature from the magnet. When the sum of these moments is larger than the moment acting around the spring joint due to the magnet attracting the armature, the armature will come away from the stop pin below. As the result of the motion of the armature, a micro-switch will be actuated, triggering an alarm signal.

Type of DETECTOR

The Vibration Switch is available in a weather-resistant version and an explosion-proof version to suit various applications.

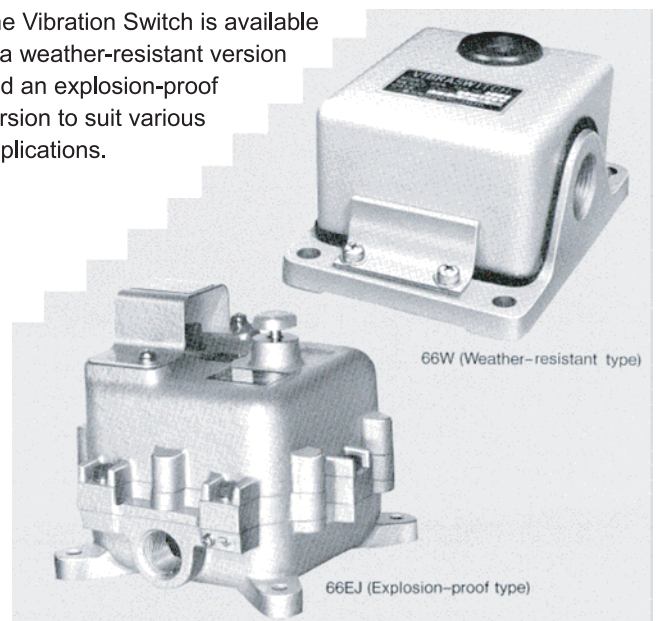

SPECIFICATIONS

Detector

Model No. 66W - □□□V... weather-resistant type
66EJ - □□□V...explosion-proof type
(V: voltage)

Operational Range:
0.5~4.5 G

Adjusting Screw:
1 G per 1 rotation
(4.5 G by 4.5 rotations)
Can be adjusted at every 0.1 G.

Accuracy:
±5% (within the range of
0 ~ 300 Hz)

Ambient Temperature:
-20 °C ~ +80 °C (66EJ: up to 40 °C)

Rating of S.P.D.T. Contacts:
AC 125 V, 3 A
DC 48 V, 1 A
DC 125 V, 0.5 A
DC 250 V, 0.25 A

DIMENSIONS

66W-type Detector

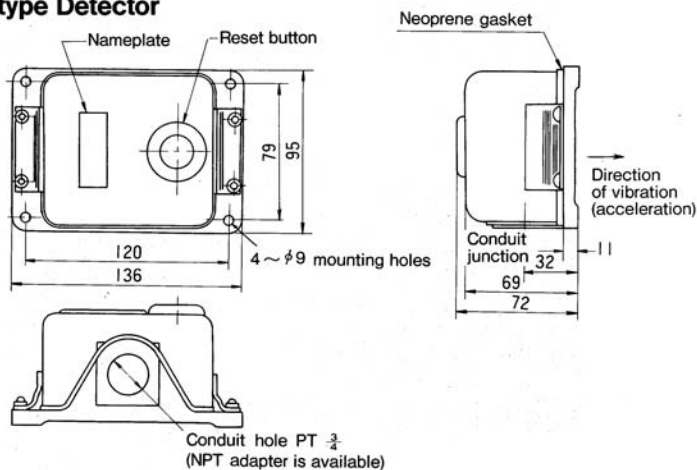

66EJ-type Detector

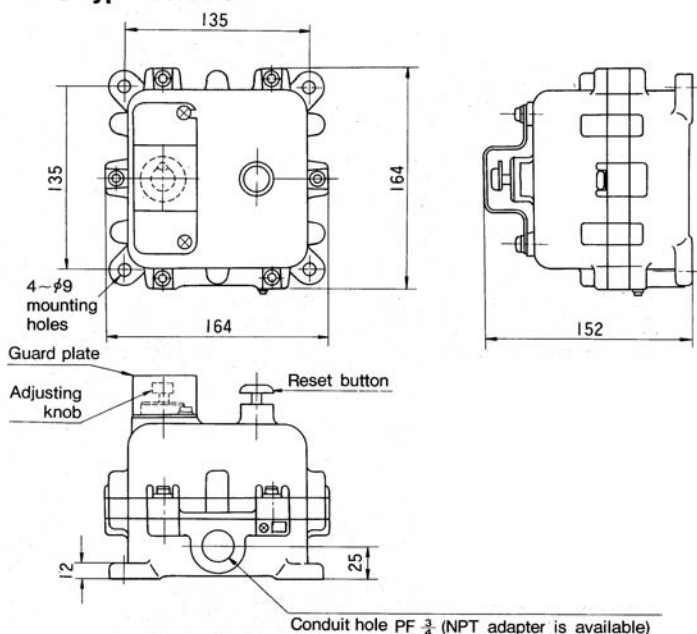

CAUTION

Before operating this equipment, you should first thoroughly read the operator's manual.

Design and specifications are subject to change without prior notice and without any obligation on the part of the manufacturer.

TOKIMEC

TOKIMEC INC.

Fluid Management Systems

www.tokimec.co.jp/ryutai/

2-16-46, Minami-kamata, Ohta-ku, Tokyo 144-8551 JAPAN
Phone +81-3-3737-8621 Fax +81-3-3737-8665